



DESIGN



SWISS



CONNECTED



DIGITAL







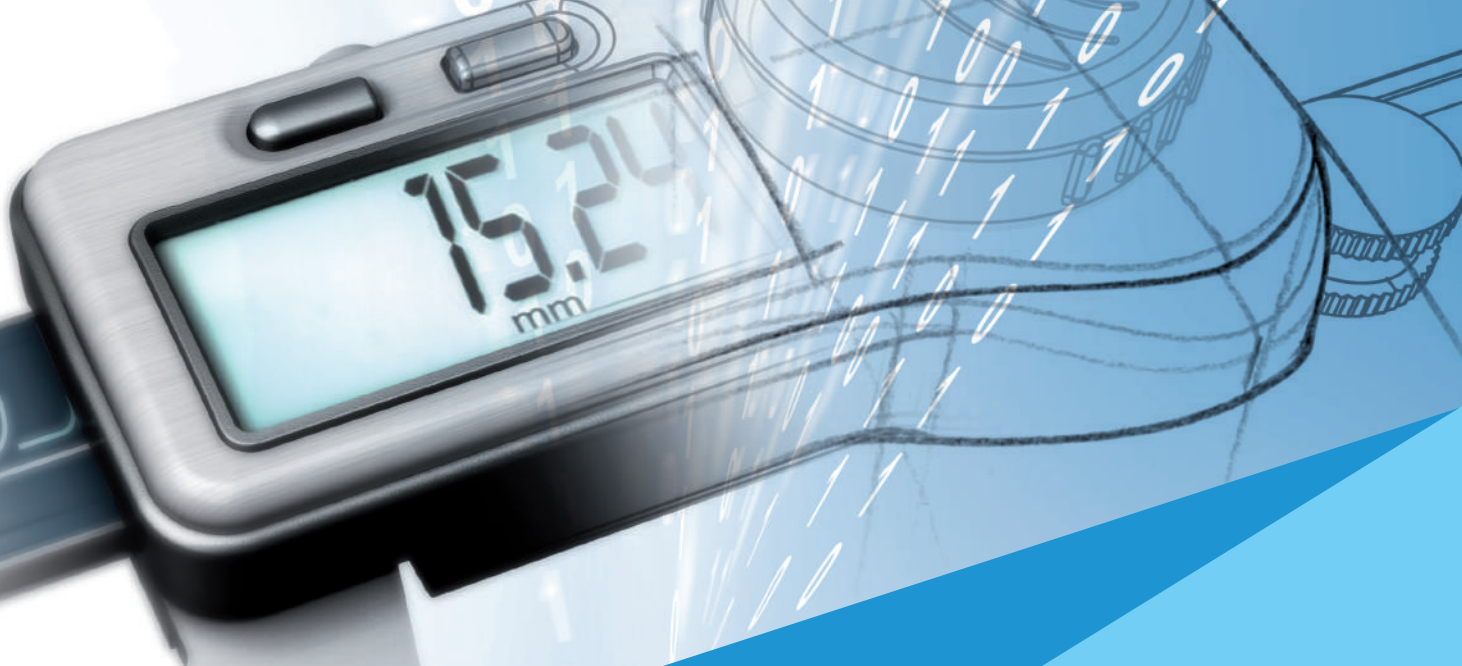













TECHNOLOGY

The alliance between
SWISS MADE
and
INNOVATION



КВАЛИТЕТ
www.qualitet.su

PART OF
HEXAGON

| | | |
|---|---|---|
| GENERAL INFORMATION | A |  |
| CONNECTIVITY | A |  |
| CALIPERS | B |  |
| EXTERNAL MICROMETERS | C |  |
| INTERNAL MEASUREMENT | D |  |
| MEASURING INSTRUMENTS FOR LARGE DIMENSIONS | E |  |
| DIAL GAUGES – ELECTRONIC AND ANALOGUE | F |  |
| LEVER-TYPE DIAL TEST INDICATORS | G |  |
| COMPARATIVE MEASUREMENT | H |  |
| MEASURING SUPPORTS AND AUXILIARY FIXTURES | I |  |
| STRAIGHTNESS, ANGLE AND INCLINATION MEASUREMENT | J |  |
| LENGTH AND ANGLE STANDARDS | K |  |
| CALIBRATION EQUIPMENT | L |  |
| SURFACE ROUGHNESS TESTING | M |  |
| HEIGHT GAUGES | N |  |
| ELECTRONIC LENGTH MEASURING EQUIPMENT | O |  |
| OPTICAL MEASUREMENT | P |  |
| COORDINATE MEASURING MACHINES | Q |  |





THE DNA OF OUR INSTRUMENTS:

- 1 – The best materials
- 2 – Guaranteed precision across the measurement
- 3 – The cutting edge of technology and innovation
- 4 – Individual inspection and certification
- 5 – Long-term reliability

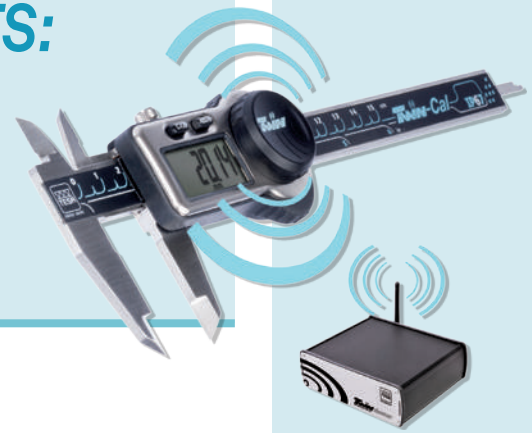

PRODUCTS

TESA tools have a strong reputation for quality, reliability and usability, and most of them proudly sport the 'Swiss Made' label.

Flagship products like the TESAMASTER micrometer, the CCMA dial caliper, the UNIMASTER large dimension gauge, the IMICRO internal micrometer and the 1D probes have been used in workshops for decades. TESA height gauges need no introduction – TESA's position as a world market leader speaks for itself.

At TESA, there is a relentless passion for innovation, and our new TESA LINK connector and wireless module are a major step forward into the digital world. Any TWIN-Cal IP40 or IP67 caliper can now communicate both ways with a computer.

Our wireless inductive probes are the result of over 3 years of R&D, and were launched in 2014. They offer unique characteristics, such as synchronised two-way communication, and guarantee reliable and fast measurements in both static and dynamic modes. A world first from TESA, they provide users with total freedom thanks to the wireless connection. SWISS MADE TESA machines are not to be outdone: they guarantee perfect measurement quality and stability over time, and have earned an excellent reputation in the world of tactile and optical metrology. By simplifying complicated operations, TESA has made quality control available to all by offering a full range of effective and flexible solutions. TESA machines are adapted to the requirements of our most demanding users, are easy to learn how to use, and provide a quick return on investment.



CUSTOMISED SOLUTIONS

For nearly 75 years, TESA has been working to solve its partners' metrological challenges. We are proud to continue offering you measurement solutions that build upon this success. We're here to help: our team of specialists have many years of experience and an unrivalled understanding of metrology. They are ready and waiting to help you develop applications that fully meet your requirements.





Dear Clients and Partners,

We are delighted to present you with our catalogue, which showcases both recent innovations and standard TESA products. It is these standard products that have forged the TESA Group's reputation over the years and made us the world leader in micro-metrology, but our new developments are not to be outdone, and are set to encourage the development of the digital factory of the future.

More than ever at TESA, our guiding principles are precision, reliability, innovation and the Swiss Made label, and we are convinced that your most difficult metrological challenges will meet their match in our standard and customised solutions.

Our expertise in dimensional measurement and commitment to training are the inspiration for the catalogue's more theoretical sections, which are full of advice and information on the art of measurement.

Enjoy!



*Stefan Ruh,
Managing Director of the TESA Group*



SERVICE

We offer a range of services, such as calibration, repair, maintenance, technical support, training and instrument customisation to meet your needs, and enable you to use your TESA instruments and machines in the best conditions possible.

For more information, please contact our customer service department, your nearest TESA branch, or fill in the customer service contact form on our website www.tesagroup.com



Customer Service TESA SA

Rue du Bugnon 38
1020 Renens, Switzerland
Tel: +41 (0)21 633 16 00
tesa-service@hexagonmetrology.com



www.tesagroup.com

REGISTER YOUR INSTRUMENT

You can now register your instrument on our website at www.tesagroup.com, and take advantage of a whole range of benefits, such as our warranty extensions on TESA height gauges.





INTERNATIONAL PRESENCE

The TESA group operates on all continents via its global distribution network.

Our Head Office in Renens is located in the homeland of Swiss watchmaking and precision engineering, in close proximity to internationally-renowned engineering schools. It is home to a Research and Development department with nearly 50 team members, and a large production site.



ALPHABETICAL INDEX

All products are also listed by order numbers on the last pages.

A

Accessories for axial probes

- Extensions for Inserts with M2 Thread 0-60
- Hemispherical Measuring Inserts, M2 Thread 0-60
- Measuring Insert with Cylindrical Measuring Face, Lock Nut for Radial Alignment, M2 Thread 0-60
- Spherical Measuring Inserts, R = 5 mm, M2 Thread 0-60
- Extensions for Measuring Inserts, Ø 4 mm, 10 – 40 mm 0-61
- Insert with Cylindrical Measuring Face, Counter Nut for Radial Alignment 0-61
- Spherical Measuring Inserts, R 1 – 8 mm, L > 18mm 0-61
- Spherical Measuring Inserts, R = 5 mm, L = 6 mm 0-61
- Spherical Measuring Insert with 4 Interchangeable Pins, R = 1,5 mm, Length 16-46 mm 0-61
- Standard Spherical Measuring Inserts, R = 1,5 mm, L = 6 mm 0-61
- Inserts with a Flat Measuring Face Ø 1,5 mm, Interchangeable Pin, Steel or Carbide 0-62
- Inserts with a Flat Measuring Face, Ø 2,5 – 3,4 mm 0-62
- Inserts with Flat Measuring Face, Ø 2 mm, Steel 0-62
- Inserts with Flat Measuring Face, Ø 5 – 10 – 20 mm 0-62
- Insert with Off-centre (6,5 mm) Narrow Face, Lock Nut for Radial Alignment 0-62
- Insert with Offset (6,5 mm) Measuring Contact Point, Lock Nut for Radial Alignment 0-62
- Inserts with Blade-shaped Measuring Face, Lock Nut for Radial Alignment 0-63
- Insert with a Flat Measuring Face, Ø 2,5 mm, Adjustable Parallelism, Counter-nut for Radial Alignment 0-63
- Insert with Narrow Measuring Face, Adjustable Parallelism, Counter-nut for Radial Alignment 0-63
- Insert with Needle Contact Point 0-63
- Insert with Offset (12 mm) Contact Point, Lock Nut for Radial Alignment 0-63

- Measuring Inserts with Ball-bearing Rollers, Lock Nut for Radial Alignment 0-63
- Clamping Elements for Axial Probes 0-64
- Spare Bellows for Axial Probes 0-64
- Spring Sets for Axial Probes 0-64

Accessories for coordinate measuring machines

- HH-T Head Q-6
- HH-MI Head Q-7
- HH-MI-M Head Q-7
- HP-T Probe Q-8
- HP-T Probe Kit Q-8
- HP-TM Probe Q-9
- HP-TM Probe Kit Q-9
- HP-T-RP Probe Q-10
- Ruby Ball Stylus, M2 Thread Q-11
- Ruby Ball Stylus, M3 Thread Q-12
- Hemispherical Styli, M2 Thread Q-13
- Hemispherical Styli, M3 Thread Q-13
- Star Styli, M2 Thread Q-14
- Star Styli, M3 Thread Q-14
- Cylindrical Styli, M2 Thread Q-14
- Parallel Styli, M2 Thread Q-15
- Extension M2 Q-15
- Extension M3 Q-15
- Cross-pieces, M2 Q-16
- Cross-pieces, M3 Q-16
- M2 Adaptors Q-16
- M3 Adaptors Q-17
- Stylus Tightening Keys Q-17
- Stylus Kit Q-18
- Basic Fixturing System Q-19
- Advanced Clamping System Q-19
- Additional Software Q-20
- Camera Kit Q-20

Accessories for Dial Gauges

- Inserts for dial gauges, axial probes, etc.
 - Execution with M2,5 thread F-25-28
- Inserts for dial gauges, axial probes, etc.
 - Execution with M2 thread F-28
- Additional accessories for dial gauges F-29



Accessories for lever dial test indicators

| | |
|---------------------------------------|------|
| – Accessories for TESATAST | G-6 |
| – Clamp | G-6 |
| – Mounting Rods | G-6 |
| – Fixing Shank | G-6 |
| – Measuring Inserts | G-9 |
| – Accessories for INTERAPID 312 | G-9 |
| – Clamping Attachment | G-9 |
| – Holders | G-9 |
| – Clamping Attachment | G-9 |
| – Reducing Sleeve | G-9 |
| – Measuring Inserts for COMPAC Models | G-13 |
| – Accessories for COMPAC | G-13 |
| – Swivel Clamps | G-13 |
| – Mounting Rods with Dovetail Grip | G-13 |
| – Mounting Rods | G-14 |
| – Fixing Shank | G-14 |
| – Clamp | G-14 |

Accessories for universal FMS probes

| | |
|--|------|
| – Insert with $\varnothing = 2$ mm Diameter Contact Pin, Hemispherical Face with $\varnothing 4$ mm Diameter Mounting Shaft for FMS Probes | O-66 |
| – Probe Inserts with a Flat Rectangular Face, $\varnothing 4$ mm Mounting Shaft for FMS Probes | O-66 |
| – Probe with 2 Cylindrical Measuring Faces with $\varnothing 4$ mm Mounting Shaft, for FMS Probes | O-66 |
| – Probe with Ball Tip $\varnothing 4$ mm for FMS Probes | O-66 |
| – Barrel Shaped Inserts for Bores, $\varnothing 6$ mm Mounting Shaft, for FMS Probes | O-67 |
| – Disc Inserts for Grooves, $\varnothing 6$ mm Mounting Shaft, for FMS Probe | O-67 |
| – Inserts with Ball Tip, $\varnothing 6$ mm Mounting Shaft, for FMS Probes | O-67 |
| – Special Inserts, $\varnothing 6$ mm Mounting Shaft, for FMS Probes | O-67 |
| – Universal Probe Holder with $\varnothing 6$ mm Mounting Shaft, for FMS Probes | O-67 |
| – Auxiliary Springs and Pneumatic Retraction Jack, for FMS Probe | O-68 |
| – Fixed Holder, for FMS Probe | O-68 |
| – Holder with Fine Adjustment for FMS Probe | O-68 |
| – Inserts with Offset Measuring Faces, for FMS Probes | O-68 |
| – Spring Set with Specific Measuring Force, for FMS Probe | O-68 |

Auxilliary Equipment

| | |
|--|------|
| – INTERAPID Depth Foot with a Flat Face | I-12 |
| – INTERAPID Depth Foot with Prismatic Measuring Face | I-12 |
| – Brown & Sharpe CENTER FINDER Centering Tool | I-12 |
| – Brown & Sharpe Positioning Block Set | I-13 |
| – Brown & Sharpe V-Block Set with Clamping Bridge | I-13 |
| – Brown & Sharpe Adjustable Parallels | I-14 |
| – ROCH Flexible Rules | I-14 |
| – ROCH Thickness Gauges | I-15 |
| – ROCH Radius Gauges | I-15 |
| – ROCH Screw Pitch Gauges | I-15 |
| – ROCH Portable Magnifier | I-16 |

B-C

Calipers

| | |
|--|------|
| – Models TESA CCMA-M | B-6 |
| – Model TESA CCMA-M, 0,01 mm | B-6 |
| – TESA CCMA-P Models | B-7 |
| – ETALON 125 Model | B-7 |
| – Depth Measuring Foot | B-8 |
| – Magnetic Magnifying Glass | B-8 |
| – Standard Models | B-9 |
| – Models with Rounded Measuring Faces for Internal Dimensions (Without Fine Adjust Device) | B-13 |
| – Models with Rounded Measuring Faces (With Fine Adjust Device) | B-13 |
| – Models with Knife-edge Jaws for External Dimensions and Rounded Measuring Faces for Internal Dimensions (Without Fine Adjust Device) | B-14 |
| – Models with Knife-edge Jaws for External Dimensions and Rounded Measuring Faces for Internal Dimensions (With Fine Adjust Device) | B-14 |
| – Accessories for INTERAPID Light | B-21 |
| – With Extra Long Jaws and Fine Adjust Device | B-22 |
| – With Hook Jaws for External Dimensions | B-22 |
| – With Knife-edge Jaws for Internal Dimensions | B-23 |
| – With Vee Bridge | B-23 |
| – For Turned Grooves | B-23 |



Comparative Measurement

- IRA 2 Comparative Gauge H-8
- Model for Sheets H-9
- Models with Open Inserts When Not in Use H-9
- Pair of Measuring Inserts in Special Version H-10
- INTERAPID SHE.30 for External Dimensions H-10
- INTERAPID SHE.35 for Internal Dimensions H-11

Connectivity

- DATA-DIRECT Software A-3
- STAT-EXPRESS Software A-4
- USB Accessories:
Adaptor Sub-D 9pm/USB,
Multiplexer USB, Foot Switch USB A-5
- TESA Portable SPC PRINTER A-6
- Wireless Connection for TWIN-STATION Receiver A-7
- NEW: Transfer of Results with TESA LINK CONNECTOR TLC A-8
- TWIN-STATION Receiver A-8
- Standard OPTO Connection A-9
- Standard Sub-D Connection A-9
- Connecting Cables from the Instrument to a PC or Computer Controlled System A-10
- Hand / Foot Switches, Adapters, Battery Chargers, Power Cables A-11
- Connecting Cables for RUGOSURF to PC or Printer A-12

Coordinate Measuring Machines

- MICRO-HITE 3D Manual Q-4
- MICRO-HITE 3D DUAL Q-5

D

Depth Calipers

- TWIN-CAL IP67
 - Models with Short Cut Measuring Face B-15
- TWIN-CAL IP67
 - Models with One Fixed Measuring Jaw B-15
- TWIN-CAL IP67
 - Models with Two Fixed Measuring Jaws B-15
- TWIN-CAL IP67
 - Models with Rotary Stop Plate B-16
- TWIN-CAL IP67
 - Small Sized Model with Steel Measuring Tip B-16
- TESA Vernier Calipers with a Flat Measuring Face B-17

- Calipers with Vernier Scale and Steel Measuring Tip B-17
- Vernier Calipers
 - Convertible Models with Short Cut Measuring Face and Steel Tip B-17
- Vernier Calipers with Rotary Stop Plate B-18
- Vernier Calipers
 - Convertible Models with Fixed Stop Plate and Short Cut Measuring Face B-18
- Removable Bridges B-18

Dial Gauges – Analogue

- Dial Ø 40 mm – Reading 0,01 mm F-11
- Dial Ø 57 / 58 mm – Reading 0,01 mm F-12
- Dial Ø 58 mm – Reading 0,01 mm – Long travel F-13
- Dial Ø 82 mm – Reading 0,01 mm F-14
- Dial Ø 40 mm – Reading 0,002 mm F-15
- Dial Ø 58 mm – Reading 0,02 mm F-16
- Dial Ø 40 mm – Reading 0,001 mm F-17
- Dial Ø 58 mm – Reading 0,001 mm F-18
- Dial Ø 82 mm – Reading 0,001 mm F-19
- Dial Ø 40 / 58 – Reading 0,1 mm F-20
- Dial Ø 40 mm – Reading 0,01 mm F-21
- Dial Ø 58 mm – Reading 0,01 mm – Long travel F-22
- Dial Ø 58 mm – Reading 0,01 mm – Standard and long travel F-23

Dial gauges – Electronic and Analogue

- TESA DIGICO 205 / 305 F-3
- TESA DIGICO 400 / 500 F-4
- TESA DIGICO 600 F-5
- TESA DIGICO 705 F-6
- Accessories for TESA DIGICO 200 – 700 F-6
- TESA DIGICO 1 / 2 F-7
- TESA DIGICO 12 F-8
- TESA DIGICO 12 – HP F-9
- Accessories for TESA DIGICO 12 F-9
- ETALON HP High precision comparators ETALON with short measuring travel F-10
- Dial Ø 40 mm – Reading 0,01 or 0,002 mm F-24

Digital Calipers

- TWIN-CAL IP67 B-3
- TWIN-CAL IP40 B-4
- TESA VALUELINE IP40 B-5
- TWIN-CAL IP67
 - Models with Rounded Measuring Faces for Internal Dimensions B-10



- TWIN-CAL IP67
– Models with Rounded Measuring Faces
for Internal Dimensions and
Knife-edge Jaws B-11
- TWIN-CAL IP67
– Models with Rounded Measuring Faces
for Internal Dimensions and Knife-edge
Jaws for External Dimensions B-12
- TWIN-CAL IP67 Horizontal Scale Unit B-19
- INTERAPID Light B-20

Digital Micrometers

- TESA MICROMASTER
Electronic Micrometers with Digital Display C-3
- MICROMASTER IP54 SET C-3
- MICROMASTER
Micrometers with Small Measuring Faces C-10
- TESAMASTER AD
Micrometers with Small Measuring Faces C-10
- MICROMASTER
Micrometers with Two Spherical
Measuring Faces C-12
- MICROMASTER
Micrometers with One Spherical
Measuring Face C-12
- MICROMASTER
Micrometers for Soft Materials C-14
- ISOMASTER AF
Micrometers for Soft Materials C-14
- MICROMASTER
Micrometers for Gear Pitch Measurement C-15
- ISOMASTER AE
Micrometers for Gear Tooth / Pitch
Measurement C-15
- Full Set of Measuring Inserts for
MICROMASTER with Interchangeable
Inserts C-16
- MICROMASTER
with 7 Pairs of Interchangeable
Measuring Inserts C-16
- MICROMASTER
Micrometers with Prismatic
Measuring Faces C-17
- Cylindrical Setting Standards
for Micrometers C-17
- MICROMASTER AC
Micrometers for Thread Measurement C-18
- ISOMASTER AC
Micrometers for Thread Measurement
Models C-18
- MICROMASTER
with Interchangeable Anvils C-22
- Dial Gauge Element for
MICROMASTER and AB Micrometers C-22

E-F

Electronic Length Measuring Equipment

- Probes with Axial Movement,
Ø 8 mm 0-6
- Probes with Axial Movement,
Ø 8 mm, with Activation of the Measuring
Bolt by Pneumatic Pressure 0-8
- USB, DC, Wireless Probes 0-10
- Probes with Axial Movement, Ø 8 mm 0-12
- Probe with Inclined Lever 0-12
- Unbranded Axial Probes with Measuring
Bolt Mounted on a Ball-bearing 0-12
- Universal FMS Probes 0-14
- GT31 Lever Probes ± 0,3 mm,
0,3 mm Measuring Travel, Inclined Lever 0-42
- Probes with parallel guidance,
± 2 mm or ± 2,9 mm,
5,8 mm measuring travel 0-43
- Probes with Parallel Guidance,
± 2 mm or ± 2,9 mm,
5,8 mm Measuring Travel 0-43
- Probes with Parallel Guidance,
± 2 mm or ± 2,9 mm, 5,8 mm Measuring
Travel – Protected Version 0-45
- TESATRONIC TT 10
Probe Display Unit 0-47
- TESATRONIC TT 20 and TT 60 Probe
Display Units 0-49
- TESATRONIC TT 80 and TT 90
Probe Display Units 0-51
- TESATRONIC TTA 20
Probe Display Unit 0-53
- Accessories for TESATRONIC TT Units 0-54
- TESA Probe Interface Boxes
– BPX Series 0-55
- TWIN-STATION Receiver
for TESA Wireless Probes 0-56
- Accessories for M4P-2 probe interface 0-57
- TESA Probe Interface Boxes
with Analogue Output – Series M4P-2 0-57
- Calibration Standards
– Dummy Probes 0-59

Electronic probe display units - up to 2 probes

- TESATRONIC TT 10 probe display unit 0-47
- TESATRONIC TT 20 and TT 60 probe
display units 0-49
- TESATRONIC TT 80 and TT 90 probe
display units 0-51
- TESATRONIC TTA 20 Probe Display Unit 0-53
- Accessories for TESATRONIC TT units 0-54



ETALON POLO Horizontal Measuring Bench

- ETALON POLO with Floating Resting Table L-11
- Measuring Inserts for Internal Measurement used with the Floating Resting Table L-12
- Bench Stand with Swivelling Plate L-12
- Base for the Computing Counter L-12
- Floating Resting Table L-12
- Stands for Checking External Dimensions L-12
- Pair of Standard Measuring Inserts for External and Internal Dimensions from 10 mm L-12
- Stand with Ø 10 mm Fixing Bores L-13
- Centering Device L-13
- Fixing Shank L-13
- Holder for a Dial Test Indicator (Lever-type) L-13
- Spindle for Calibrating Dial Gauges, Dial Test Indicators and such like L-13

External Micrometers

- Interchangeable Thread Inserts for TESA Micrometers Series AC C-19
- Setting Standards for Screw Thread Micrometers
 - Metric, 60° or 55° flank angle C-19
- XB Wires for Screw Threads C-20
- Set of 16 Pairs of XB Wires for Thread Measurement C-20
- INTERAPID Setting Standards C-24
- ETALON Cylindrical Step Gauges C-24
- Guide Collars for Setting Standards C-24
- Micrometer Stands C-25
- Optical Flats with Two Parallel Faces C-25
- Set of Depth Rods for Micromaster C-26
- MICROMASTER Depth Micrometers C-26
- ISOMASTER AQ Depth Micrometers C-26
- MICROMASTER Micrometer Heads C-27
- TESAMASTER AR Micrometer Heads C-27
- ETALON 266 Micrometer Heads C-28
- ISOMASTER AR Micrometer Heads C-28

G

Gauge Block Comparators

- TESA UPD
 - For direct and comparative measurements L-4
- TESA UPC L-6
- Gauge Blocks for the Calibration of Comparators L-8
- TESA UP Software Programme for Value Processing L-8
- Additional Gauge Block Set for Calibration of the TESA UPD System L-9
- TESA UPT L-9

H

Height Gauges

- TESA-HITE Magna 400 / 700 N-4
- TESA-HITE 400 / 700 N-7
- TESA-HITE Plus M 400 / 700 N-10
- TESA MICRO-HITE 350 / 600 / 900 N-12
- Control Panel for TESA MICRO-HITE 350 / 600 / 900 N-15
- TESA MICRO-HITE Plus M 350 / 600 / 900 N-16
- Control Panels for TESA MICRO-HITE Plus M 350 / 600 / 900 N-19
- TESA IG-13 Probe Set for Perpendicularity Measurement N-20
- TESA-µHITE N-21
- Optional Accessories for TESA-µHite N-23
- Sets of Accessories for Height Gauges N-24
- Sets of Accessories for Height Gauges N-25
- Sets of Accessories for Height Gauges N-26
- Sets of Accessories for Height Gauges N-27
- Sets of Accessories for Height Gauges N-28
- Probe Holder No. 00760223 for Inserts with 8 mm Diameter N-29
- Optional Accessories for Use with Insert Holder No. 00760223 N-29
- Accessories for Measuring Perpendicularity by Means of a Dial Test Indicator N-30
- Accessories for ETALON Height and Scribing Gauges with Digital Display N-31
- ETALON Height and Scribing Gauges with Digital Display N-31

I-J-K

Internal Measurement

- TESA IMICRO with Analogue Indication – Metric D-3 K-5
- TESA IMICRO with Analogue Indication – Full Metric Sets D-4 K-5
- TESA IMICRO CAPA μ SYSTEM with Digital Display D-5 K-6
- TESA IMICRO CAPA μ SYSTEM with Digital Display – Full Sets D-6 K-6
- TESA IMICRO CAPA μ SYSTEM with Digital Display – Partial Sets D-7 K-6
- Cases for Sets of IMICRO Analogue D-8 K-7
- Cases for Single IMICRO Digital Instruments D-8 K-7
- Cases for Sets of IMICRO Digital D-8 K-8
- Cases for Single IMICRO Analogue Instruments D-8 K-8
- Accessories for Both TESA IMICRO and TESA IMICRO CAPA μ SYSTEM – Extensions for Deep Hole Measurement D-8 K-8
- Accessories for Both TESA IMICRO and TESA IMICRO CAPA μ SYSTEM – Centring Devices for TESA IMICRO D-8 K-9
- ROCH ALESOMETER with Analogue Indication, Metric D-9 K-9
- ROCH ALESOMETER with Analogue Indication – Full Metric Sets D-10 K-9
- Extensions for Depth Increase for ROCH ALESOMETERS – Analogue Models D-10 K-9
- TESA ALESOMETER CAPA μ SYSTEM with Digital Display D-11 K-9
- TESA ALESOMETER CAPA μ SYSTEM with Digital Display – Partial Sets and Components D-12 K-9
- ETALON INTALOMETER 531 D-13 K-9
- ETALON INTALOMETER 531, Metric Sets D-14 K-9
- TESA TRI-O-BOR D-15 K-9
- Extension for Depth Increase TESA TRI-O-BOR D-16 K-9
- TESA TRI-O-BOR, Full Sets D-16 K-9
- TESA Setting Rings and Setting Masters D-17 K-9
- TESA Gauge Block Set M47, Metric K-5
- TESA Gauge Block Set M88, Metric K-5
- TESA Gauge Block Set M122, Metric K-6
- Special Versions K-6
- TESA Gauge Block Set M112, Metric K-6
- TESA Optical Flats K-7
- TESA Monochromatic Light Unit K-7
- Brown & Sharpe Angle Gauges K-8
- Steel Balls – Brown & Sharpe Steel Balls K-8
- TESA CARY Plug Gauges, Diameters 0,050 to 0,300 mm – Type TDH K-9
- TESA CARY Plug Gauges, Diameters 0,050 to 0,300 mm – Type TLH K-9
- TESA CARY Plug Gauges, Diameters 0,050 to 0,300 mm – Type TLH-5 – Type TLH-10 K-10
- TESA CARY Plug Gauges, Diameters 0.050 to 0,300 mm – Type TTLH K-10
- TESA CARY Steel Plug Gauges, Diameters 0,3 to 10 mm – Type TXH K-11
- TESA CARY Steel Plug Gauges, Diameters 0,3 to 10 mm – Type TTXH K-11
- TESA CARY Tungsten Carbide Plug Gauges, Diameters 0,3 to 6 mm – Type TTCH K-12
- TESA CARY Tungsten Carbide Plug Gauges, Diameters 0,3 to 6 mm – Type TCH K-12
- TESA CARY Measuring Pins in Steel, \emptyset 0,10 to 10 mm, – Type PNH with Handle, for Thread Measurement K-13
- Accessories for Plug Gauges and Setting Rings K-13
- TESA CARY Steel Ring Gauges, Diameters 0,151 to 5 mm – Type BAH K-14
- TESA CARY Carbide Ring Gauges, Diameters 0,060 to 5 mm – Type BCH K-14
- TESA CARY Steel Ring Gauges, Diameters 5 to 30 mm – Type BOMa K-15
- TESA CARY Tungsten Carbide Ring Gauges, Diameters 5 to 30 mm – Type BOMm K-15
- Accessories for Plug Gauges K-16

Lever-type Dial Test Indicators

- TESA IP65 Electronic Dial Test Indicators G-2
- SWISSTAST Standard Models G-4
- TESATAST Perpendicular Models G-4
- TESATAST Standard Models G-4

L

Length and Angle Standards

- TESA Gauge Block Set M32, Metric K-5



- Indicator Sets with Small Support G-5
- TESATAST Measuring Inserts G-5
- TESATAST Lateral Models G-5
- INTERRAPID 312 Perpendicular Models G-8
- INTERRAPID 312 Standard Models G-8
- Dial Test Indicator Sets, Complete with Accessories – INTERRAPID 312 Standard Models G-8
- COMPAC Series 210 – Standard Models, Metric G-11
- COMPAC Series 220 – Perpendicular Models, Metric G-11
- COMPAC 240 Reduced Range Models G-12
- COMPAC 230 Parallel Models G-12

M-N

Measuring Instruments for Large Dimensions

- TESA UNITEST Internal Micrometer E-3
- TESA UNIMASTER Universal Measuring Instrument E-4
- TESA INOTEST Comparative Measuring Instrument E-6
- ETALON 532 Internal Micrometer E-8
- ROCH Metric Periphery Tapes E-8

Measuring Stands

- INTERRAPID Magnetic Support with Articulated Arm (small) I-3
- INTERRAPID Magnetic Support with Articulated Arm I-3
- INTERRAPID Magnetic Support with High Precision Articulated Arm I-4
- INTERRAPID Magnetic Support with Flexible Arm I-4
- INTERRAPID Inclined Magnetic Support I-5
- INTERRAPID Support with Suction Base and Articulated Arm I-6
- INTERRAPID Small Measuring Support and Table Ø 49 mm I-7
- INTERRAPID Measuring Support with Inclined Frontal Arm I-7

- INTERRAPID UA 1 Table Measuring Support with Ground Table Surface I-8
- INTERRAPID UD12 Support I-8
- INTERRAPID Table Measuring Stands with Granite Grade 00 I-9
- UJ 15 Model I-10
- UJ 15G Model I-10
- Accessories for Small Magnetic Stands I-10
- INTERRAPID UA 30 Measuring Stand (Without Measuring Arm) I-11
- Accessories for UA 30 I-11

Micrometers with analogue indication

- TESAMASTER High Precision Micrometers with Digital Counter Reading to 0,1 mm C-4
- ETALON MICRORAPID 226 with 1 mm Revolution C-5
- ETALON 260 Standard Models with Analogue Indication C-5
- TESA ISOMASTER Standard Models with Analogue Indication C-6
- Set of 4 TESA ISOMASTER Micrometers C-6
- ETALON Basic to 0,01 mm C-7
- Set of 4 ETALON Basic Micrometers 0,01 mm Reading C-7
- Protective Cover for Micro-Etalon 225 C-8
- MICRO-ETALON 225 – Precision Micrometers with a Dial Indicator C-8
- ETALON MICROSPER 280 C-9
- MICRORAPID Micrometers with Small Measuring Faces C-11
- ISOMASTER AD Micrometers with Small Measuring Faces C-11
- ETALON Micrometers with One Spherical Measuring Face C-13
- Spherical Element for External Micrometers C-13
- ETALON Basic for Tube Wall Thickness Measurement C-21
- ISOMASTER AB with Interchangeable Anvils C-23
- Interchangeable Anvils for ISOMASTER ABY Series C-23

O

Optical Measurement

- PLASTIFORM Set P-27
- Accessories for PLASTIFORM P-28

P-Q-R

Probe Accessories

- Adaptor Cable:
DIN 5p Connector to USB Type A Connector 0-58
- Fixing Bracket
for TESA GT 31 Lever Probe 0-65
- Manual Measuring Bolt Retraction
for Axial Probes 0-65
- Probe Inserts
for GT 31 Lever Probes 0-65
- Connectors for Electro-pneumatic Pump
for Measuring Bolt Retraction 0-69
- Electro-pneumatic Pump
for Measuring Bolt Retraction 0-69
- Extension Cable
for Probes, Lengths = 1 – 20m 0-70

Probes with axial movement, Ø 8 mm

- Standard Probes,
± 1 mm, 4,3 mm Travel (GT21) 0-16
- Standard Probes,
± 1 mm, 4,3 mm Travel (GT22) 0-17
- Standard Probes ± 2 mm,
4,3 mm Bolt Travel, Linear Travel 0-18
- Standard Probes,
± 2 mm, 10,3 mm Travel,
with Long Retraction Travel 0-19
- Standard Probes ± 5 mm,
10,3 mm Bolt Travel, Extended Range 0-20
- GT 21 HP High Precision Probes,
± 0,2 mm, 4,3 mm Rravel 0-21
- GT 22 HP High Precision Probe,
± 0,2 mm, 4,3 mm Travel 0-22
- Pneumatic Probes ± 1,5 mm,
3,2 mm Bolt Travel, Linear 0-23
- Pneumatic Probes ± 2 mm,
10,3 mm Bolt Travel,
with Long Retraction Travel 0-24
- Pneumatic Probes ± 5 mm,
10,3 mm Bolt Travel, Long Travel 0-25
- GT 41 / GT 42 Miniature Probes,
± 0,3 mm, 0,7 mm Bolt Travel 0-37
- GT 43 / GT 44 Miniature Probes,
± 1,0 mm , 2,1 mm Bolt Travel 0-38
- Probes, Unbranded Execution, Series 410 ±
1 mm, 2,5 mm Range, Short Body 0-39
- Probes, Unbranded Execution,
Series 160 ± 1 mm, 3,3 mm Bolt Travel,
Short Body, Ø 6 mm 0-40
- Probes, Unbranded Execution, Series 430
and 451, ± 0,5 mm, 1,25 and 2,10 mm
Measuring Bolt Travel, Miniature 0-41

Profile Measurement Machines

- TESA-SCAN 52 REFLEX-Click P-3
- TESA-SCAN 25 P-4
- TESA-SCAN 50 P-5
- TESA-SCAN 50 CE+ P-6
- TESA-SCAN 50+ P-7
- TESA-SCAN 80/ 80+ P-8
- Fixturing Systems P-9
- TESA-REFLEX Scan Software P-13
- Pro-Measure Software P-14

Profile projectors

- TESA-SCOPE II 300V and 300V Plus P-20
- Telecentric Lenses for
TESA-SCOPE 300V and 300V Plus P-22
- Accessories for TESA-SCOPE
Vertical Model P-22
- TESA-SCOPE II 355H P-23
- Telecentric Lenses for
TESA-SCOPE 355H and H Plus P-25
- Accessories for TESA-SCOPE
Horizontal Model P-25
- TS100 Digital Readout P-26
- TS300 or TS300E Control Panel P-26

S

Straightness, Angle and Inclination Measurement

- TESA CLINOBEVEL 1 USB
Electronic Inclionometer J-3
- TESA CLINOBEVEL 2
Electronic Inclionometer J-4
- TESA MICROBEVEL 1
Inclinometer J-5
- TESA NIVELTRONIC
Electronic Levels with Analogue Display
and Integrated Galvanometer J-6
- TESA Spirit Levels – for Assembly J-7
- TESA Precision Spirit Levels J-8
- TESA Precision Spirit Levels with Frame J-8
- TESA Precision Spirit Levels Magnetic,
Square Models with Magnetic Inserts J-9
- TESA Precision Level with Micrometer
Element J-9
- TESA Spirit Inclinometer
with Protractor and Micrometer Element J-10
- Accessories for Clinometers and Levels J-11
- ROCH Bevelled Straight Edges J-12



- ROCH Flat and Try Squares in Steel
– Accuracy Class 1 J-12
- Brown & Sharpe Try Square Set J-13
- ROCH Bevelled Edge Squares
– Accuracy Class 00 J-13
- Angle Protractor with Digital Display J-14
- EAC Angle Protractor with Dial J-15
- ETALON Angle Protractor
with Vernier Scale J-15
- Brown & Sharpe Angle Protractor
– Multiple Combinations J-16
- Brown & Sharpe Sine Bar J-16

Surface roughness testing

- TESA RUGOSURF 20 M-4
- TESA RUGOSURF 10G M-7
- TESA RUGOSURF 90G M-10
- TESA PROFILE SET 2 mm M-13
- RUGOSOFT Software M-14
- MEASUREMENT STUDIO Software M-15
- PROFILE STUDIO Software M-16
- Standard Probes M-17
- Optional Probes for RUGOSURF surface
roughness gauges M-18
- Optional Probes for RUGOSURF 90 M-19
- PR Dot Matrix Printer M-20
- Accessories for PR Dot Matrix Printer M-21
- Other Accessories for RUGOSURF M-22
- Chargers and Rechargeable Batteries M-22
- Granite Bases with Measuring Support
Column M-23
- Ra Roughness Standards M-24
- Setting Standard for PROFILE SET M-24
- RUGOTEST
Roughness Comparison Specimens M-25

T

TESA VERIBOR Bore Gauges

- TESA VERIBOR Light H-5
- TESA VERIBOR H-6
- Set of Extensions H-7
- Depth Extensions H-7
- Dial Gauge Protection Guard H-7
- Accessories for IRA-2 Comparative Gauge H-8

TESA-VISIO Accessories

- Additional Lenses for 6,5 Zoom P-17
- Additional Lenses for 12x Zoom P-17

- Diascopic Parallel Light P-18
- Fixing Kit for TESA VISIO P-18
- Foot Switch for Data Capture P-18

TESA YA Bore Gauges

- Special Executions H-4
- Optional Accessories for TESA YA Bore
Gauges H-4

Tool Set

- TESA SWISS TOOL SET C-29
- TESA DUO-SET 1 C-30
- TESA DUO-SET 2 C-30
- TESA DUO-SET 8 C-31
- TESA DUO-SET 9 C-31
- TESA DUO-SET 14 C-32
- TESA DUO-SET 13 C-32
- TESA DUO-SET 15 C-33
- TESA DUO-SET 16 C-33

U

USB, DC, Wireless Probes

- Wireless Probe ± 2 mm 0-26
- Wireless Probe ± 5 mm,
Large Measuring Range 0-27
- Wireless Pneumatic Probe $\pm 1,5$ mm 0-28
- Wireless Pneumatic Probe ± 5 mm,
Large Measuring Range 0-29
- USB Probes ± 2 mm,
4,3 mm Range 0-30
- USB Pneumatic Probes $\pm 1,5$ mm,
3,1 mm Bolt Travel 0-31
- USB Probes ± 5 mm,
10,3 mm Bolt Travel,
Extended Measuring Range 0-32
- DC Probes ± 2 mm (Output Signal in V) 0-33
- DC Probes ± 5 mm (Output Signal in V),
with Extended Measuring Range 0-34
- DC Miniature Probes ± 1 mm
(Output Signal in V) 0-35
- Lever DC Probes $\pm 0,3$ mm
(Output Signal in V) 0-36

V-W-X-Y-Z

Vision Systems

- TESA-VISIO 200 GL P-15
- TESA-VISIO 300 GL MANUAL P-16
- TESA-REFLEX Vista Software P-19
- TESA-REFLEX Vista Compare Option P-19

QUANTITIES AND UNITS

International System of Units (SI)

F: Système international d'unités (SI)

D: Internationales Einheitensystem (SI)

Derived units (of measurement)

F: Unités dérivées

D: Abgeleitete Einheiten

| Quantity | SI base unit | |
|---------------------------|--------------|--------|
| | Name | Symbol |
| length | metre | m |
| mass | kilogram | kg |
| time | second | s |
| electric current | ampere | A |
| thermodynamic temperature | kelvin | K |
| amount of substance | mole | mol |
| luminous intensity | candela | cd |

| Quantity | Unit | | Relationship to SI base unit |
|----------------------|--------|--------|---|
| | Name | Symbol | |
| plane angle | radian | rad | 1 rad = 1 m 1 rad = 57,295 779 51° |
| frequency | hertz | Hz | 1 Hz = 1 s ⁻¹ |
| force | newton | N | 1 N = 1 m kg s ⁻² |
| pressure | pascal | Pa | 1 Pa = 1 m ⁻¹ kg s ⁻² |
| power | watt | W | 1 W = 1 m ² kg s ⁻³ |
| electrical potential | volt | V | 1 V = 1 m ² kg s ⁻³ A ⁻¹ |

Decimal multiples and submultiples of the base unit "metre"

| Unit | Symbol | m | cm | mm | µm | nm |
|----------------------|-----------|--------------------------|------------------------|---------------------|---------------------|---------------------|
| kilometre | km | 1 ³ m | 1000 m | 1 000 000 mm | | |
| Metre | m | 1 m | 1 m | 1 000 mm | 1 000 000 µm | |
| decimetre | dm | 10 ⁻¹ m | 0,1 m | 100 mm | 100 000 µm | |
| centimetre | cm | 10 ⁻² m | 0,01 m | 10 mm | 10 000 µm | |
| Millimetre | mm | 10⁻³ m | 0,001 m | 0,1 cm | 1 mm | 1 000 000 nm |
| tenth millimetre | | 10 ⁻⁴ m | 0,000 1 m | 0,1 mm | 100 µm | 100 000 nm |
| hundredth millimetre | | 10 ⁻⁵ m | 0,000 01 m | 0,01 mm | 10 µm | 10 000 nm |
| Micrometre | µm | 10⁻⁶ m | 0,000 001 m | 0,001 mm | 1 µm | 1 000 nm |
| tenth micrometre | | 10 ⁻⁷ m | 0,000 000 1 m | 0,000 1 mm | 0,1 µm | 100 nm |
| hundredth micrometre | | 10 ⁻⁸ m | 0,000 000 01 m | 0,000 01 mm | 0,01 µm | 10 nm |
| Nanometre | nm | 10⁻⁹ m | 0,000 000 001 m | 0,000 001 mm | 0,001 µm | 1 nm |

Definition of the metre

F: Définition du mètre – D: Meterdefinition

"The metre is defined as the distance travelled by light in vacuum during a time of 1/299 792 458 of a second."

17th General Conference on Weights and Measures, 1983.

Reference temperature

F: Température de référence

D: Bezugstemperatur

For measuring instruments and workpieces, ISO R1 assesses this temperature is 20°C.

The temperature of 20°C is assumed to be valid for any size, material measure, measurement result etc., unless otherwise specified.

MEASUREMENT TASKS

Inspecting

F: Contrôler – D: Prüfen

Determining whether a test object complies with specified requirements (e.g. as regards both dimensions and form).

Measuring

F: Mesurer – D: Messen

Obtaining a value (e.g. length value) measured by comparison against a master standard (e.g. material measure).

Calibrating

F: Etalonner – D: Kalibrieren

Establishing the actual deviation of a measuring instrument from desired value.

This is usually done through measurement operations. The result of a calibration is documented in the form of a calibration certificate and can be used later on for adjustment purposes, for instance.



INDICATION RELATED DEFINITIONS

Indication

F: Indication – D: Anzeige

The indication, which provides the information about the measured value, is directly perceptible by human senses. It may be optical, acoustic or based on any other output feature.

Displaying devices may either have a digital, analogue or any other special indication.

For material measures, the indication matches displayed value.

Note: According to the standards, the terms "analogue" and "digital" are only used to differentiate the methods of measurement. Therefore, they should not be used for the definition of the indications.



Scale indication

F: Indication de l'échelle – D: Skalenanzeige

Scale indication is the readable position of a scale mark.



Line scale

F: Echelle à traits – D: Strichskale

A line scale is the successive number of graduation (scale marks) on a scale.



Scale spacing

F: Longueur d'une division (d'échelle)

D: Teilstrichabstand

Scale spacing is expressed in length units as the distance between two successive scale marks measured along the same line by a marker (e.g. the end of a pointer).

Line scales

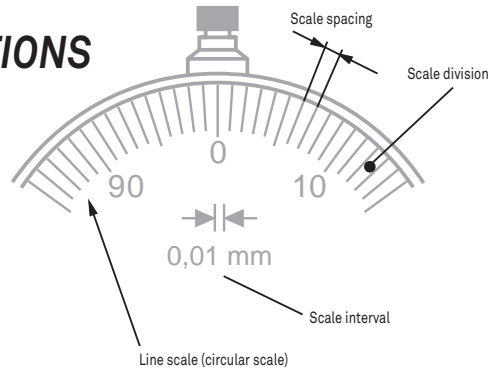
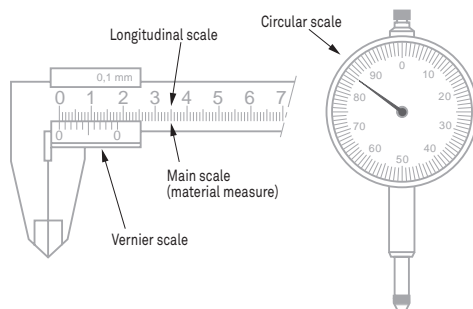

Scale division

F: Division d'échelle (échelon) – D: Skalenteil

Part of a scale between two successive scale marks.



Scale interval

F: Echelon, valeur d'une division (d'échelle)

D: Skalenteilungswert

The scale interval is the difference between the values matching two successive scale marks. This characteristic is expressed in the units marked on the scale.



Vernier interval

F: Valeur du vernier – D: Noniuswert

The vernier interval is the alteration of the value of a measurand, which in turn changes the indication by one scale division of the vernier scale.

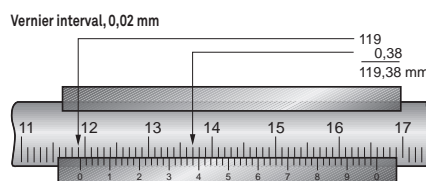
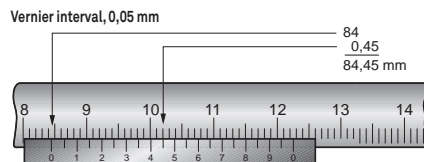

Numerical (digital) indication

F: Indication numérique

D: Ziffernanzeige

The numerical indication is shown in the form of a digit (succession of digits).



Numerical scale

F: Echelle numérique – D: Ziffernskale

A numerical scale is a succession of digits (usually 0 to 9). On a multi-scale, the single numerical scales are arranged side by side in a decimal fraction.



Numerical interval

F: Valeur du pas (échelon) numérique

D: Ziffernschritt

The numerical interval is the alteration by one numerical value of the indication. This characteristic, which matches the scale interval, is expressed in the units of the measurand.



METROLOGICAL DEFINITIONS



Range of indication

F: Etendue d'indication – D: Anzeigebereich
 The range of indication lies between the highest and lowest display values of a measuring instrument.



Measuring range

F: Etendue de mesure – D: Messbereich
 The measuring range of an indicating device is the range within which the measured values cannot exceed the maximum permissible errors. For tools having several measuring ranges, these errors may vary from a range to another. The measuring range may well be contained within the related whole range of indication.



Measuring span

F: Champ de mesure – D: Messspanne
 This span equals the difference between both first and last values of the measuring range as specified.



Displacement range

F: Etendue de déplacement – D: Verstellbereich
 Measurand related extent within which the measuring range can be moved.



Application range

F: Etendue d'application
 D: Anwendungsbereich
 The application range is equal to the sum of both displacement and measuring ranges.
 Note: The first and last values make each range different from one another.

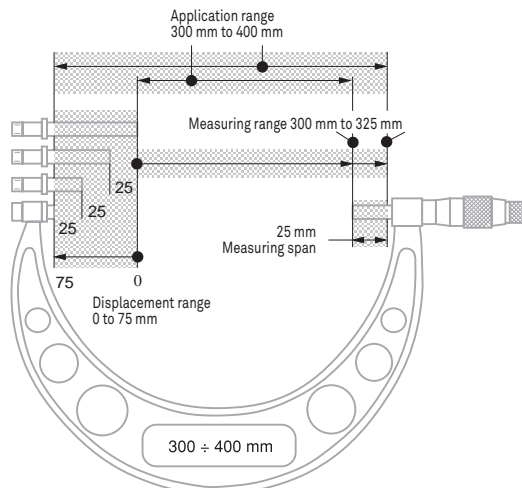

Measurand

F: Mesurande – D: Messgröße
 Physical quantity of a measurement. In other words, the measurand is the length or the angle as measured or to be measured.

Measured value

F: Valeur mesurée – D: Messwert
 Any measured value expresses the result of a measurement. Therefore, this value is directly associated with the measurand and further allocated to the output feature (e.g. display) of a measuring instrument or device. A measured value is expressed as the product of both numerical value and unit. The measured value includes the true value plus the random and systematic errors of the relevant tool.

Result of measurement

F: Résultat de mesure – D: Messergebnis
 Product of a measured value once corrected on the basis of the known systematic errors. This result is further increased by the uncertainty of measurement, which includes the random as well as any unknown systematic error.

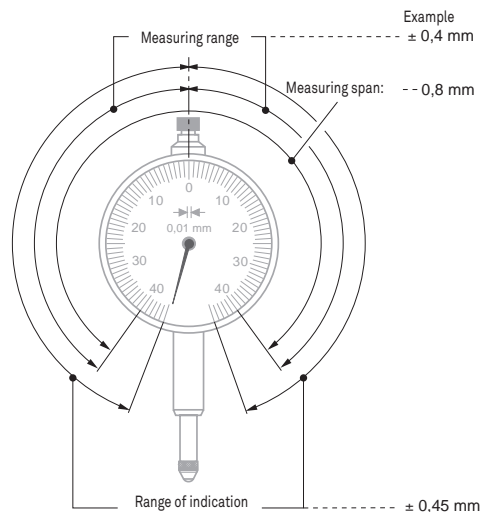
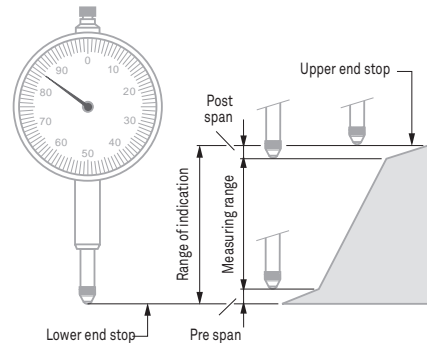
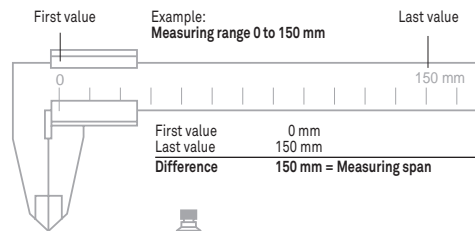

 **Permissible limits of a metrological characteristic MPL**

F: Limites tolérées d'une caractéristique métrologique MPL

D: Grenzwerte eines Messtechnischen Merkmals MPL

Extreme permissible values of a metrological characteristic of a given measuring equipment, according to specifications or standards of the manufacturer or others.

 **Maximum permissible errors for a metrological characteristic MPE**

F: Erreurs maximales tolérées d'une caractéristique métrologique MPE

D: Grenzwerte für Messabweichungen für ein messtechnisches Merkmal MPE

Extreme values of the permissible error for a metrological characteristic of a given measuring equipment, according to specifications or standards of the manufacturer or others.

 **Repeatability**

F: Fidélité (répétabilité)

D: Wiederholpräzision

Ability of a measuring instrument to repeat the results obtained from the same measurand successively measured in the same direction, also under the same conditions.

Repeatability, which delivers important information for the assessment of the uncertainty of measurement, is quantitatively expressed as standard deviation of dispersion values.

 **Repeatability limit**

F: Fidélité (répétabilité) limite

D: Wiederholgrenze

Extreme value for repeatability.

 **Maximum permissible errors G**

F: Erreurs maximales tolérées G

D: Fehlergrenzen G

These errors are assimilated to the "Permissible limits of a metrological characteristic MPL".

Being related to both upper and lower highest deviations of a measuring instrument, they are usually symmetrical in practical metrology and, therefore, stated as single value, without any sign.

 **Deviation span of indication**

F: Champ d'erreur d'indication

D: Abweichungsspanne

This deviation span matches the distance from the highest to the lowest point of a coordinate as shown on the relevant diagram. The value obtained is either applicable to whole or the local measuring span or measuring range.

All required measurements are carried out in one direction (without reversal of the measuring force) – i.e. with upward plunger movement for a dial gauge. For those needed to establish the whole deviation span, they are performed in both directions (with reversal of the measuring force) – i.e. with upward and downward movement of the plunger for a dial gauge.

 **Hysteresis**

F: Hystérésis

D: (Messwert-) Umkehrspanne

Hysteresis expresses the difference between various indications of a measuring instrument.

This value is achieved through measurements of the increasing/decreasing value of the same measurand, taken under the same conditions.

Hysteresis, which is quantitatively stated as standard deviation of value dispersion, can be determined anywhere within the measuring span or range. Its amount can also be obtained from the diagram of the deviation span as a whole.

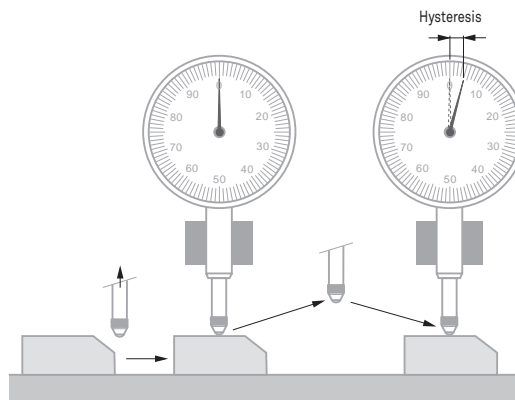
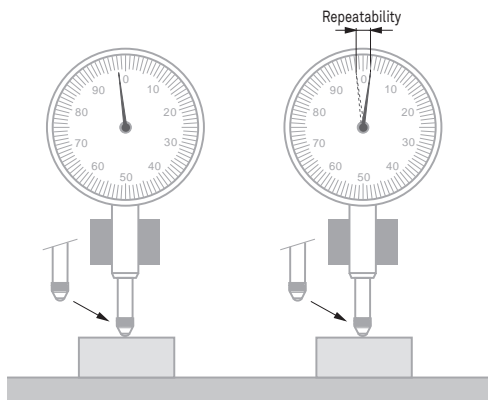



DECISION RULES FOR PROVING CONFORMANCE OR NON-CONFORMANCE WITH SPECIFICATIONS

Relationship with the uncertainty of measurement

ISO 14253-1, which is a part of "Geometrical Product Specification GPS", provides "Rules for establishing the conformance or non-conformance with specifications". These rules are valid for "Inspection by measurements of workpieces and measuring equipment".

This ISO standard makes allowances for the uncertainty of measurement – or more precisely for the true uncertainty of any measurement whenever the conformance or non-conformance with a given specification must be proved. So, for a workpiece, the specification matches a preset tolerance while being equal to the maximum permissible errors for a metrological characteristic (MPE) for a measuring instrument.

Any given specification is a constant, whereas the measurement uncertainty is a variable which is affected by many components. Therefore, the zone of conformance or non-conformance depends on the size of the effective expanded uncertainty U .

Rule for proving conformance

Conformance is proved when the measurement result y is lying within the specification zone, reduced on either side by the expanded uncertainty U . Consequently, workpieces or measuring instruments can be accepted as far as their conformance with the specification is proved by the manufacturer (supplier).

Rule for proving non-conformance

Non-conformance is proved when the measurement result y is lying beyond the specification zone, increased on either side by the expanded uncertainty U . In such a case, the relevant measuring instruments can be rejected if the purchaser (customer) gives evidence of its non-conformance.

Neither conformance nor non-conformance can be proven

This often happens when the measurement result y associated with the expanded uncertainty U includes either of the LSL or USL specification limits. As a result, workpieces or measuring instruments can neither be automatically accepted nor rejected.

For such "dead end cases", it is advisable to follow the rule below.

- Repeat all measurements based on a reduced uncertainty, so that conformance or non-conformance can clearly be demonstrated. Usually, proceeding in this way benefits to the party that's able to provide the needed proof.

- Come to a mutual agreement providing the procedure to be applied if such cases arise.

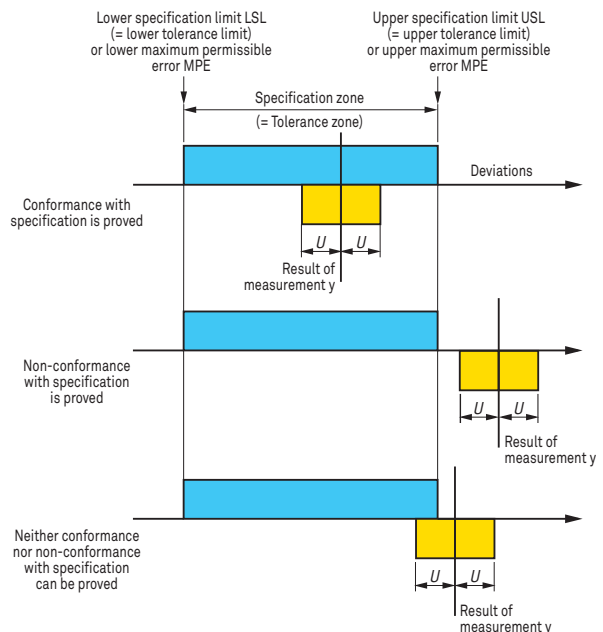
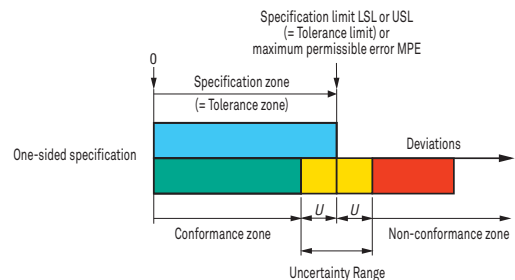
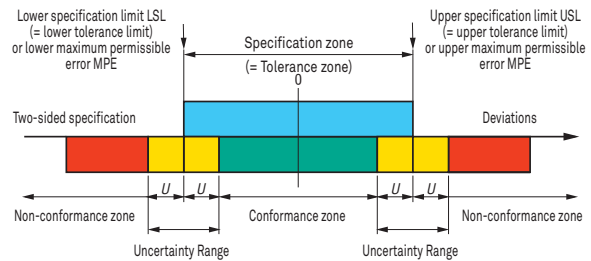

TRACEABILITY TO NATIONAL STANDARDS

All measuring equipment consistently used on our production site is traceable to national standards or reference fixtures through our quality management system.

Traceability is established by recalibration at regular intervals with documentary evidence as specified in the standards.

The illustration that follows shows the hierarchy of calibrations within the chain of traceability. The example set for the transfer of accuracy to our MICRO-HITE height gauges also shows how they are calibrated. Each feature is supplied with a free SCS calibration certificate issued by our laboratory, which is officially accredited by the Swiss Calibration Service.

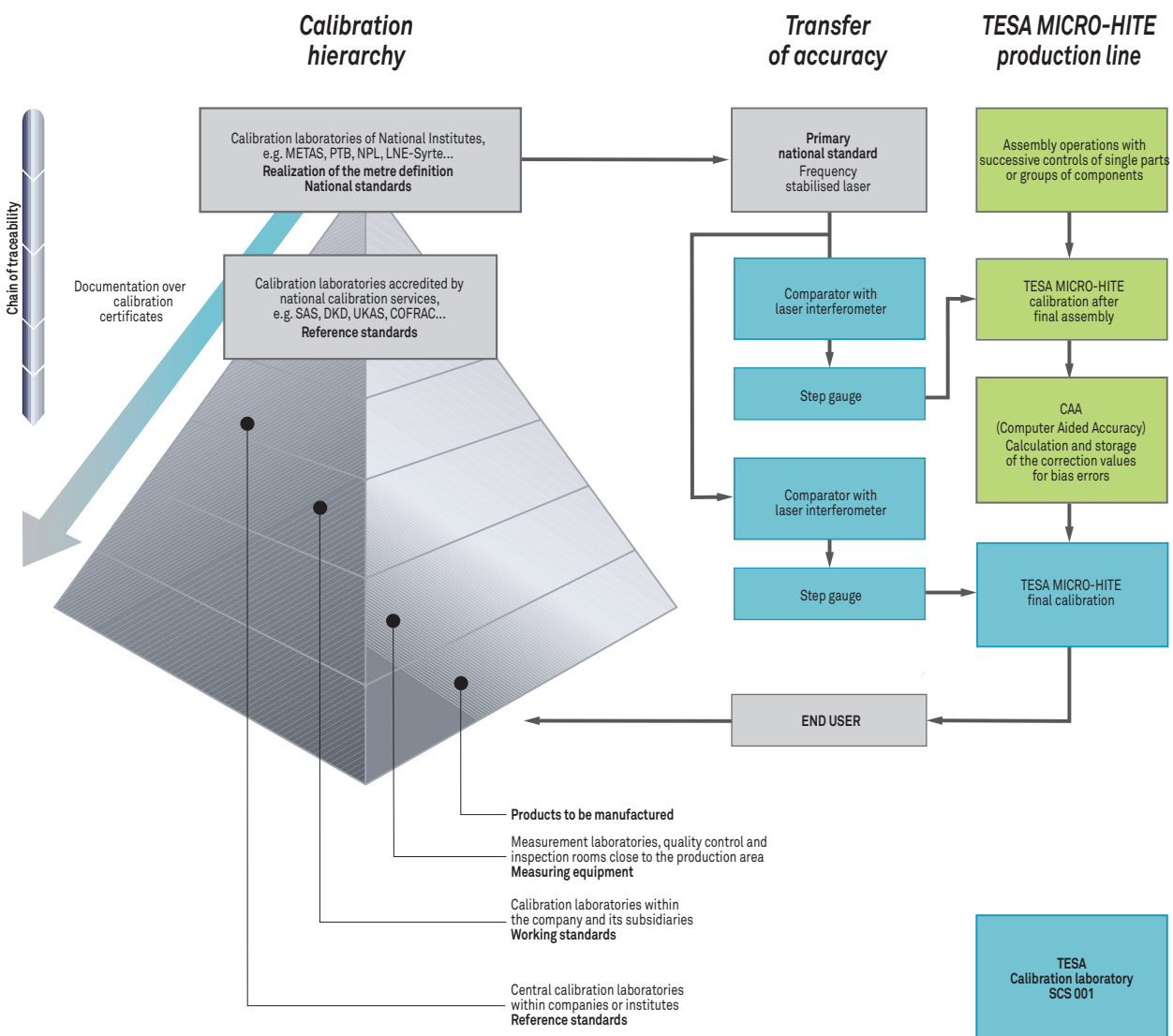

Connectivity

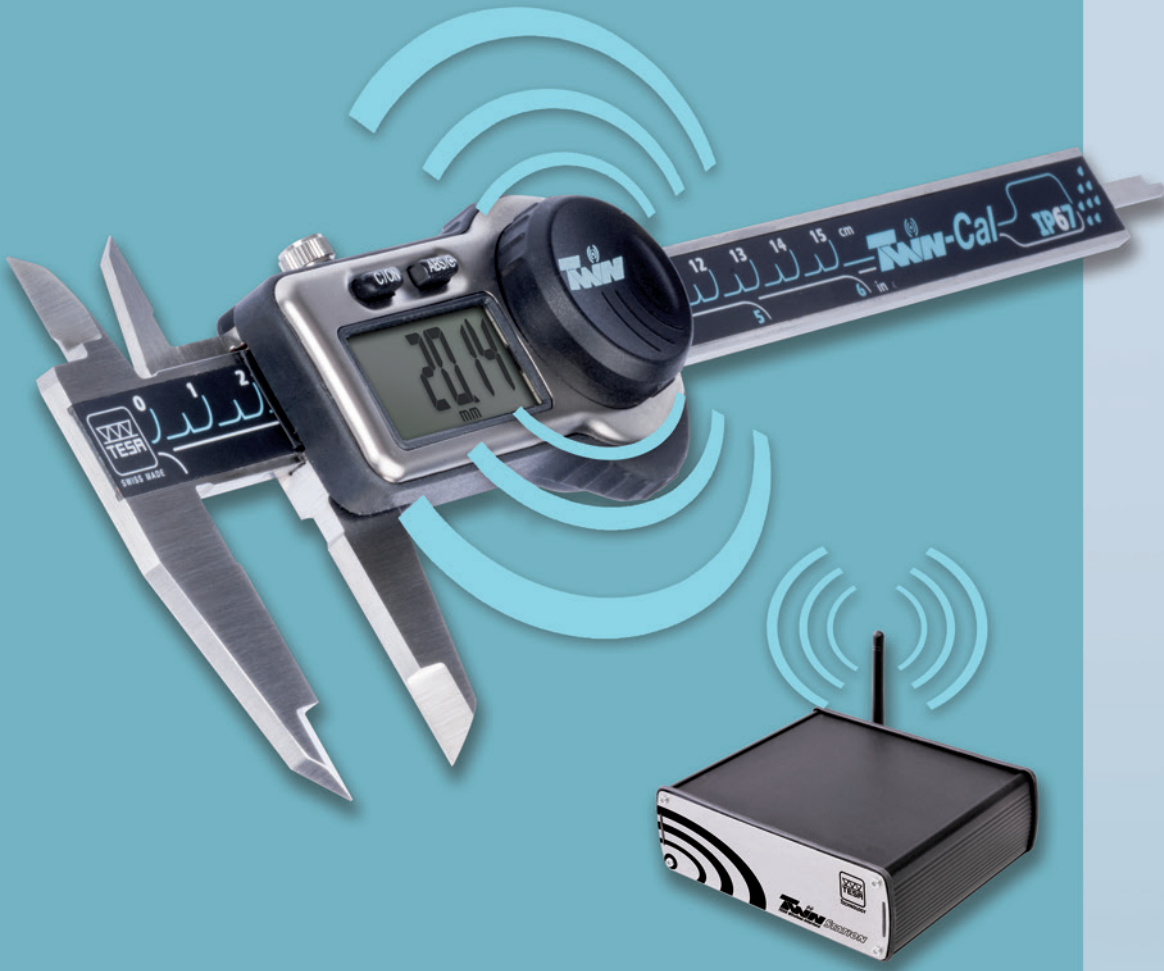

TESA SOFTWARE, CABLES AND LINKS FOR THE TRANSFER OF MEASURING RESULTS.

Inspection, traceability and cost reduction have a growing significance in all industrial sectors. This requires not only high quality metrology instruments, but also software suitable for evaluation and further analysis of the measurements carried out.

| PRODUCTION | | INSPECTION | | EVALUATION | ARCHIVING | |
|------------|--|--|--|------------------------------|-----------|---|
| | | | | | | TESA DATA-DIRECT List of measurements, archiving, customised results calculations, traceability, statistics. |
| | | | | | | TESA STAT-EXPRESS Statistical analysis of measurements, control charts, traceability and sharing of results. |
| | | | | | | TESA PRINTER SPC Simple statistics, without the need for a PC, documented traceability. |
| | | Measuring instrument or machine (VISION, SCAN or MH3D) | | Software or portable printer | | Database Electronic file (PDF) Printed report |

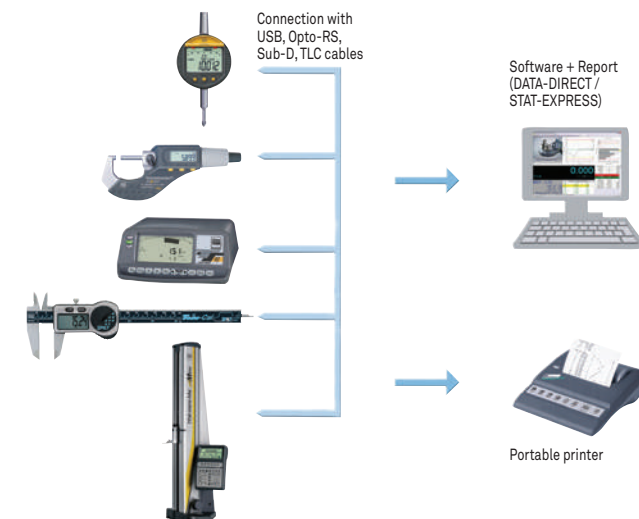

TESA offers various types of connection between measuring instruments and a PC as well as software for the management of results so that the production process can be optimised, quality improved and documents for traceability can be created.

DATA-DIRECT Software

DATA-DIRECT software is an easy way to collect and report results in real time from the majority of the measuring instruments in the TESA range that have a data output.

DATA-DIRECT is supplied not only with serial input/output drivers specially configured for TESA's products, but also for those purchased from other manufacturers. It works effectively to give data transfer for your data sheets, database, statistical modules or any other Windows-based applications.

With this user-friendly software you will be able to create your own reports for component inspection.

Minimum system requirements to run DATA-DIRECT:

- Pentium 4 or equivalent
- 512 MB RAM (live memory)
- 10 GB HD
- Windows XP, Windows 7 (32 or 64 bits)

A demonstration version can be downloaded free of charge from the TESA website at www.tesagroup.com

| Date | Lot No. | Operator | Customer | Instrument | Measure | Date | Time |
|------------|------------|----------|----------|----------------------|---------|------------|----------|
| 12.03.2009 | 13.10.4678 | XXX | TESA | OPTO-USB - cal IP 67 | 1.640 | 21.01.2010 | 12:06:06 |
| | | | | USB Probe GT21 | -1.033 | 21.01.2010 | 12:06:06 |
| | | | | OPTO-USB - cal IP 67 | 1.640 | 21.01.2010 | 12:06:07 |
| | | | | USB Probe GT21 | -1.033 | 21.01.2010 | 12:06:07 |
| | | | | OPTO-USB - cal IP 67 | 1.640 | 21.01.2010 | 12:06:07 |
| | | | | USB Probe GT21 | -1.033 | 21.01.2010 | 12:06:08 |
| | | | | OPTO-USB - cal IP 67 | 1.640 | 21.01.2010 | 12:06:09 |
| | | | | USB Probe GT21 | -1.033 | 21.01.2010 | 12:06:09 |
| | | | | OPTO-USB - cal IP 67 | 1.640 | 21.01.2010 | 12:06:10 |
| | | | | USB Probe GT21 | -1.033 | 21.01.2010 | 12:06:10 |
| | | | | OPTO-USB - cal IP 67 | 1.640 | 21.01.2010 | 12:06:12 |
| | | | | USB Probe GT21 | -1.033 | 21.01.2010 | 12:06:12 |
| | | | | OPTO-USB - cal IP 67 | 1.640 | 21.01.2010 | 12:06:13 |
| | | | | USB Probe GT21 | -1.033 | 21.01.2010 | 12:06:13 |
| | | | | OPTO-USB - cal IP 67 | 1.640 | 21.01.2010 | 12:06:15 |
| | | | | USB Probe GT21 | -1.033 | 21.01.2010 | 12:06:15 |

List of measured values within a third party software, e.g. MS Excel

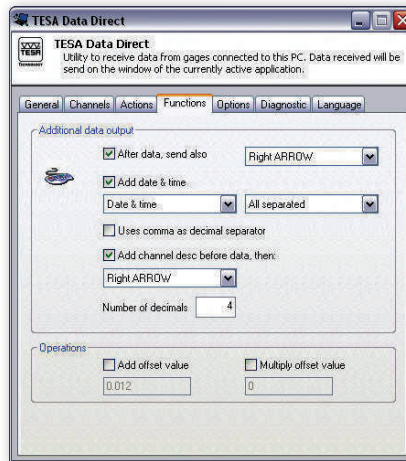

Tab function providing the facility to present the measured values

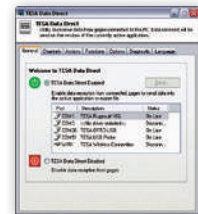

DATA-DIRECT: main window

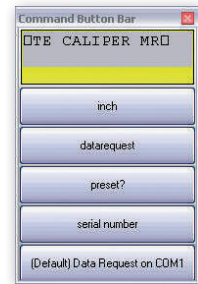

Customisable tool bar



Real time display of the measured value in a separate window

| | | | |
|-----------------|---------------------------------|--|----------------------|
| | | | Included in delivery |
| 04981001 | DATA-DIRECT Software and dongle | TESA DATA-DIRECT installation CD with licence key (dongle) USB and user instructions (PDF version) | |

| TESA DATA-DIRECT Software | |
|---|--|
| TESA Instruments compatible with DATA-DIRECT | OPTO-RS Cables – OPTO-USB Cables – Height gauges (TESA-HITE, MICRO-HITE) – USB probes – Surface roughness gauges RUGOSURF 10 / 20 / 10G / 90G – TESA MICRO-HITE 3D Reflex machines – TESA-SCOPE TS300 – TPS presetting bench – BPX probe interface – TWIN-STATION wireless probe interface – TESA wireless systems – TLC-TWIN wireless transceiver |
| Other instruments compatible with DATA-DIRECT | Custom made instruments with RS232 output – Instruments from other makers: Mitutoyo: DMX3 - DMX8 – Steinwald single 6 – Etc. |
| Functions | Export of results to .csv file – ASCII commands – Real time display of measured results on a PC (except for models using the Rf-USB receiver) |



STAT-EXPRESS Software

STAT-EXPRESS is a dedicated software package that enables the application of quality assurance into your manufacturing processes. It allows the downloading, reporting, transfer and storage of your quality-oriented control charts.

STAT-EXPRESS is compatible with all TESA's products – from calipers through to CMM or Vision machines. As an integrated software tool, STAT-EXPRESS provides the flexibility required for easy data transfer from most of the electronic gauges currently available on the market.

STAT-EXPRESS offers the ability to create reports including measured values obtained from a single instrument or several handtools, assign tolerances, calculate statistics, print out various measurement reports, compute XR control charts, and much more.



Measuring display with the option of adding operational instructions, accompanied with a photo or drawing

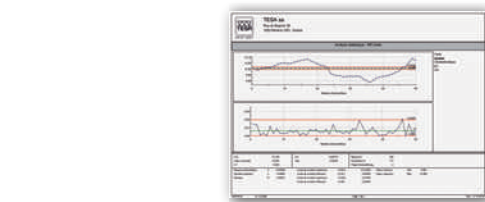

Simultaneous data acquisition from several measurement programmes

XR Control chart

Minimum system requirements to run STAT-EXPRESS:

- Pentium 4 or equivalent
- 512 MB RAM (live memory)
- 10 GB HD
- Windows XP, Windows 7 (32 or 64 bits)

A demonstration version can be downloaded free of charge from the TESA website at www.tesagroup.com

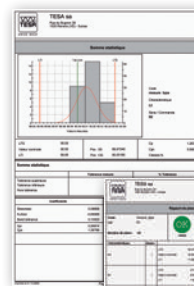

Detailed measuring report for each feature measured



Detailed measuring report for each part measured, together with serial number

| | | |
|----------|--|--|
| | | |
| 04981002 | STAT-EXPRESS software and dongle | Included in delivery |
| 04981004 | STAT-EXPRESS Machine software and dongle | TESA DATA-DIRECT installation CD with USB licence key (dongle) and user instructions (PDF version) |
| | | Installation CD with USB licence key (dongle) and user instructions (PDF version) |

| STAT-EXPRESS Software | |
|---|---|
| TESA instruments compatible with STAT-EXPRESS | OPTO-RS cables – OPTO-USB cables – Height gauges (TESA-HITE, MICRO-HITE) – USB probes – Surface roughness gauges: RUGOSURF 10 / 20 / 10G / 90G – TESA MICRO-HITE 3D Reflex machines – TESA-SCOPE TS300 – TPS presetting bench – BPI Probe interface– BPX probe interface – TWIN-STATION wireless probe interface – TESA wireless systems – TLC-TWIN wireless emitter-receiver |
| Other instruments compatibles with STAT-EXPRESS | Custom made instruments with RS232 output – Instruments from other makers: Mitutoyo: DMX3 - DMX8 – Steinwald single 6 – etc. |
| Features | DATA-DIRECT included – Export of results to .csv file – Import of .csv files – Table of all measured results – XR control charts – Report by part measured – Report by feature measured – Simultaneous data acquisition – Overall report with statistics – Measuring report in .pdf or .html format etc.– Security protection set for each user |

USB Accessories: Adaptor Sub-D 9p/m/USB, Multiplexer USB, Foot Switch USB



S47120002



S47120003



04761071

| No | = | L, m | Connector (to PC or system) |
|-----------|--|------|-----------------------------|
| S47120002 | USB-D-Sub 9p/m adapter cable | 0,1 | USB |
| S47120003 | USB multiplexer with 7 USB 2.0 ports. with external power supply, Max 4x 04761062 and 04761063. | | USB |
| 04761071 | USB footswitch. For simultaneous data request from DATA-DIRECT or STAT-EXPRESS software of all connected instruments | 2 | USB |

TESA Portable SPC PRINTER

TESA portable intelligent printer designed for the inspection of finished parts or incoming goods – Provides SPC statistics and prints out measurement results with graphical representations.

The TESA SPC PRINTER can be connected not only to TESA measuring instruments, but also to those provided with a DIGIMATIC output – Your TESA SPC PRINTER is capable of recognising the plug in tool and will execute the appropriate configuration automatically.



TESA SPC Printer

- Memory capacity : 9999 single values for one feature per sample.
- Two operating modes: «Normal» and «Tolerance».
- Limits of size quickly set on the display of the connected instrument with subsequent transfer to TESA PRINTER SPC.
- Output of statistical values printed out with graphical representations.
- Output of reports with headings to be filled in by the operator.
- Hardcopies printed in preferred language (English, German, French, Italian or Spanish).
- Battery-powered (6 V) printer unit for use on the move (optional).

| | |
|--|--|
| No | = |
| 06430000 | SPC PRINTER EU Portable. With memory, SPC, value classification and graphs. RS232 interface |
| <i>DELIVERED WITH THE FOLLOWING ACCESSORIES:</i> | |
| 04765013 | Roll of printer paper, width = 110 mm for TESA SPC Printer |
| 04761054 | Mains adapter /battery charger 100 ÷ 240 VAC 50 ÷ 60 Hz, 6,6 Vdc, 750 mAh supplied without cable |
| 04761055 | EU Mains cable for 04761054 adapter |
| <i>OPTIONAL ACCESSORIES:</i> | |
| 04761056 | USA Mains cable |
| 04768035 | Battery charger 6V, 0,5AH |

- 180 x 180 x 84 mm (W x D x H)
- Paper width: 110 mm. Print mode: 40 signs/line
- RS232 for data inputs (9-pin male, trapezoid connector) DIGIMATIC (Anselly connector, 10-pin) Connector with mini-jack for remote triggering of data transfer
- Mains adapter 100 to 240 Vac, 6,6 Vdc. Optional accessory: 6 V rechargeable battery pack.
- 10°C to 40°C
- 10°C to 60°C
- IP40 (IEC 60529)
- EN 50081-1, EN 50081-2, EN 50082-1, EN 50082-2
- 0,55 kg
- Packed suitable for shipping
- Serial number
- Declaration of conformity

| | "Normal" Mode | "Tolerance" Mode |
|--|---------------|------------------|
| Lower size limit (min.) | – | ● |
| Upper size limit (max.) | – | ● |
| Tolerance | – | ● |
| Number of values taken: | | |
| number of samples | ● | ● |
| < smallest dimension | – | ● |
| > largest dimension | – | ● |
| % out of tolerance | – | ● |
| Lowest value listed | ● | ● |
| Highest value listed | ● | ● |
| Dispersion R | ● | ● |
| Arithmetical mean | ● | ● |
| Standard deviation sn, sn-1 | ● | ● |
| Indication of capacity Cp, Cpk | – | ● |
| Graphical representations: | | |
| Position of each single value within the tolerance zone (10 classes) | – | ● |
| Graphical representations: | | |
| Histogrammes | – | ● |
| Display (LED) - Classification of the value measured: Green for pass, yellow for rework, red for reject | – | ● |



1 x CR2032 3,0 V,
230mAh



12 months. Can
be influenced by
battery level.



- 10°C to 60°C
Humidity max 80%
without conden-
sation



10°C to 40°C.
Humidity max 80%
without conden-
sation



EN 61326-1
EN 61000-4-3
ROHS, according to
2002/95/CE
EMC, according to
2004/108/CE
DEEE, according to
2002/96CE
REACH 1907/2006
ETSI EN 300 440 - 2
(CH et EU)
CFR and FCC 15.249

Wireless Connection for TWIN-STATION Receiver

The ultimate in flexibility and freedom of movement.

TESA TLC-TWIN wireless technology offers the flexibility of a hand tool thanks to bidirectional communication made possible by an instrument equipped with a TLC (TESA Link Connector) also compatible with the:

- TLC-TWIN-emitter/receiver station
- TLC-USB connecting cable
- TLC-Digimatic connecting cable.

*** The sale of the TLC-TWIN is currently restricted to EU countries, Switzerland USA and Canada

*** Please contact TESA for further information.

Up to 48 instruments can be managed by the TWIN-STATION receiver over a maximum range of 12 m.

The IP67 degree of protection of an instrument is preserved, even when the TLC-TWIN is connected.

When a visual check that the measured result has been sent to the computer is not possible, an indication on the display of the instrument enables the user to confirm that the result has been sent and received.



TESA IP67 caliper used
with a TLC-TWIN



TLC-TWIN Wireless
emitter-reciever
(04760180)

No



Operating
range, m



Compatible with
connector
TLC (TESA Link
Connector)



Diameter,
mm



Weight,
g

04760180 TESA TLC-TWIN wireless emitter-receiver.
Compatible with any instrument fitted
with a TLC (TESA Link Connector)

~ 12
(dependent on
conditions)

OPTIONAL ACCESSORIES:

05030012 TWIN-STATION BPW Probe box

04981001 DATA-DIRECT software and dongle

04981002 STAT-EXPRESS software and dongle



TWIN-STATION Receiver

TWIN-STATION: Receiver for wireless TLC-TWIN emitter-receiver units
 Receives input signals from wireless TLC-TWIN emitter-receiver units
 Output signals – digital, RS232

- Direct connection to a PC via the USB port.
- Optimal use for your measuring tasks as up to 48 instruments equipped with TLC-TWIN can be connected to this unit.
- Great reliability.

*** the sale of TWIN-STATION is currently limited to EU countries, Switzerland, USA and Canada
 *** Please contact TESA for further details.

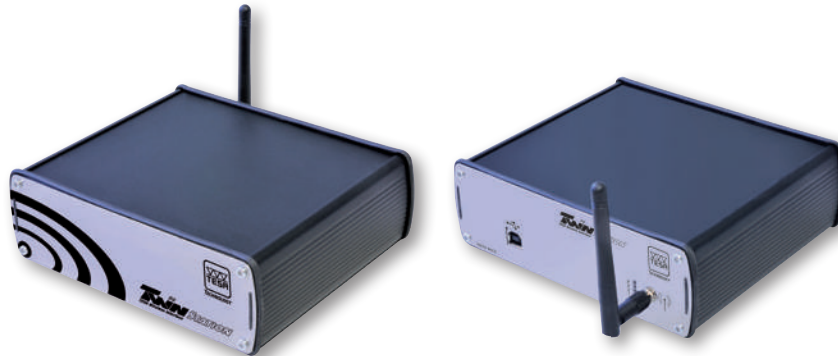

TWIN-STATION (front view)

TWIN-STATION (rear view)

| No | = | A | ⚙️ | 📦 |
|----------|--|-------------------------------------|---|------------|
| | | Number of instruments with TLC-TWIN | Power supply | Weight, kg |
| 05030012 | TWIN-STATION for TLC-TWIN wireless data transmission | 48 | Power supply via: - USB port of the PC - connected USB hub - USB hub of the BPX interface | 0,85 |

- Housing case in aluminium
- Power supply via the connection of the USB cable: - directly to the PC (USB Port) to a mains powered USB hub
- 10°C to 60°C
- 10°C to 40°C
- 80%, non-condensing
- IP 40 (IEC 60529) (DIN 40050)
- IEC/EN 61326-1 U.S. 47 CFR part 15, subpart B, Class B digital device
- Packed suitable for shipping
- Declaration of conformity
- Serial number identification
- Data transfer delay from digital serial output (USB): depends on the operating system of the computer.
- RS232
- 55 x 172 x 155 mm (H x W x D)
- USB Cable 1,80 m
- 0,85 kg
- For a temperature of 20° C and a relative humidity of ≤ 50%: Digital output: ± (0,05 + 0,15% of the measuring range)

NEW: Transfer of Results with TESA LINK CONNECTOR TLC

TESA presents its new connectivity concept: the TLC connector that allows freedom of movement, flexibility, and ease of use, all combined.

Once an instrument is equipped with a TLC connector:

- 1) There is no longer any need to choose between a model with or without data output.
- 2) There is inbuilt compatibility for both cable and wireless connectivity.
- 3) A TLC connector can also be used for connection to a USB interface, a DIGIMATIC interface or for wireless connection, using a suitable cable or emitter-receiver unit, see table below:

Instrument equipped with a TLC connector. For example, TESA TWIN-CAL IP67 caliper



| Wireless connection | Cable connection | |
|--|--|--|
| TLC-TWIN Two way wireless emitter-receiver unit | TLC-USB Two way communication cable | TLC-DIGIMATIC Two way communication cable |
| | | |
| + | + | + |
| TWIN-STATION receiver base station for signals from the wireless TLC emitter-receiver unit | Interface with USB port | DIGIMATIC* interface |
| | | |
| Personal computer | | |

* Please check with TESA for the list of equipment and instruments compatible with TESA-DIGIMATIC



OPTO AND SUB-D CONNECTION

Standard OPTO Connection







Any connecting cable is defined by each of the connectors fitted at either end of the cable principally to suit the computer, and the measuring instrument being used. To achieve highest compatibility levels, TESA uses only standardized and proven connectors.

Examples of instruments with type Opto connector:

TESA-CAL IP67 / IP65 – TESA MICROMASTER – TESA IMICRO –
TESA ALESOMETRE – TESA DIGICO 10 / 11 / 205 / 305 / 400 / 500 / 600 / 705 –
TESATRONIC TT20 / TT60 / TT80 / TT90 – INTERAPID - Light

| No | = |  |  |  |
|-----------|---|---|---|---|
| | | L, m | Connection (to instrument) | Connection (to PC or system) |
| 04761062 | Opto-USB cable, duplex, bidirectional communication | 2 | Opto-RS232 | Type A USB |
| 04761046 | Opto-RS cable, simplex, 2 m, one way communication: from the instrument to the PC | 2 | Opto-RS232 | Sub-D 9p/f Simplex |
| S47010022 | Opto-RS cable, simplex, 5 m, one way communication: from the instrument to the PC | 5 | Opto-RS232 | Sub-D 9p/f Simplex |
| 04761049 | Opto-RS cable, duplex, 2 m, bidirectional communication | 2 | Opto-RS232 | Sub-D 9p/f Duplex |
| S47010024 | Opto-RS cable, duplex, 5 m, bidirectional communication | 5 | Opto-RS232 | Sub-D 9p/f Duplex |
| 04761027 | Connecting cable without connector | 2 | Opto-RS232 | Without connector |





| Current systems | Compatible connectors | |
|--|---|---|
|  |  |  |
| TESA PRINTER SPC | Sub-D 9p/f | Ansley 10p/f |
|  |  |  |
| Computer | USB | Sub-D 9p/f |

Standard Sub-D Connection

RS232, Sub-D 9p/m connector connecting cables for the following machines or precision handtools: TESA MICRO-HITE / TESA-HITE / TESA- μ HITE / TESA TG / 3D Machines



| No | = |  |  |  |
|-----------|---|---|--|---|
| | | L, m | Connector (to instrument) | Connector (to PC or system) |
| 04761063 | Sub-D 9p/m to USB cable, 2M | 2 | Sub-D 9p/m | USB |
| 04761052 | Extension cable, Sub-D 9p/f to 9p/m, 2 m | 2 | Sub-D 9p/m | Sub-D 9p/f |
| S47010025 | Extension cable, Sub-D 9p/f to 9p/m, 10 m | 10 | Sub-D 9p/m | Sub-D 9p/f |
| S47120002 | Sub-D 9p/m to USB adapter cable | 0,1 | Sub-D 9p/m | USB |



Connecting Cables from the Instrument to a PC or Computer Controlled System



04760181



04760182



Instrument connection: special CLINOBEVEL



04761038



Instrument connection: special DIGICO 12



PC/system connection: Ansley 10p/f



Instrument connection: MiniDIN 8p/m



Instrument connection: Special for DIGICO 1 or 2

| No | = | L, m | Connection (to instrument) | Connection (to PC or system) |
|-----------|--|------|--|------------------------------|
| 04760181 | TESA TLC-USB CABLE for instruments with a TLC connector | 2 | TLC (TESA Link Connector) | USB |
| 04760182 | TLC-DIGIMATIC CABLE for instruments with a TLC connector | 2 | TLC (TESA Link Connector) | Ansley connector 10 pin/f |
| 04761023 | Cable: miniDIN 8p/m to Sub-D 9p/f, 2 m for TT10 and MICRO-HITE manual versions 10/11/12 | 2 | MiniDIN 8p/m | Sub-D 9p/f |
| 04761024 | Cable: miniDIN 8p/m to Sub-D 25p/m, 2 m for TT10 and MICRO-HITE manual versions 10/11/12 | 2 | MiniDIN 8p/m | Sub-D 25p/m |
| 04761038 | Cable: miniDIN 8p/m to Sub-D 25p/m for DIGICO 1 and 2, with powered display | 3 | Special connector for DIGICO 1 or 2 | Sub-D 25p/f |
| S47078588 | Cable for DIGICO 1 or 2 and TESA SPC printer | 2 | Special connector for DIGICO 1 or 2 | Ansley connector 10 pin/f |
| 04761060 | RS232 cable with external power supply | 2 | Specially for DIGICO 12 and TESA IP65 electronic lever type dial test indicators | Sub-D 9p/f |
| 03969007 | RS232 Sub-D 9p/f to Sub-D 9p/f, 3 m cable for TESA-REFLEX MH3D, TESA-SCOPE | 3 | Specially for DIGICO 12 and TESA IP65 electronic lever type dial test indicators | Sub-D 9p/f |
| S53300165 | USB Cable for CLINOBEVEL 1 L = 1,8 m | 1,8 | Special connector for CLINOBEVEL 1 | USB |
| S53070174 | USB Cable for CLINOBEVEL 2 L = 2,5 m | 2,5 | Special connector for CLINOBEVEL 2 | Sub-D 9p/f |

Hand / Foot Switches, Adapters, Battery Chargers, Power Cables



04768001



04768000







04761054

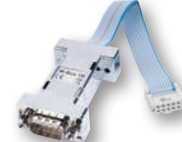

04761017



S47001891

|  |  |  |  |  |
|---|--|---|--|---|
| | | L, mm | Connection (to instrument) | Connection (to PC or system) |
| 04768000 | Hand switch for triggering data transfer. Jack plug, 1,8 m – to TESA SPC PRINTER – to TESATRONIC (TT) display units | 1,8 | – | Jack plug |
| 04768001 | Foot switch for triggering data transfer. Jack plug, 1,8 m – to TESA SPC PRINTER – to TESATRONIC (TT) display units | 1,8 | – | Jack plug |
| 04761017 | Adapter ADP-01 Sub-D 9p/f to Sub-D 25p/m | | – | – |
| S47001891 | DIGIMATIC adapter for 04761046 cable Sub-D 9p/m to Ansley 10p/f | 0,2 | – | Sub-D 9p/f or Ansley 10p/f |
| 04761054 | Mains adapter /battery charger 100 ÷ 240 VAC, 50 ÷ 60 Hz, 6,6 Vdc, 750 mAh, supplied without cable | 2 | DC-Jack | – |
| 04761055 | EU mains cable for 04761054 | 1,5 | – | – |
| 04761056 | USA mains cable for 04761054 | 1,5 | – | – |
| 04761037 | Mains cable 230V for DIGICO 1 or 2 | 2 | Special connector for DIGICO 1 or 2 | – |
| 04761057 | Mains cable 110V for DIGICO 1 or 2 | 2 | Special connector for DIGICO 1 or 2 | Sub-D 9p/f |



Connecting Cables for RUGOSURF to PC or Printer

Connecting cables for RUGOSURF roughness gauges



04760099



06960062 version 3



058213



056109



| | |
|-----------------|--|
| 04760099 | Cable RUGOSURF 20 to PC |
| 06960062 | Cable RUGOSURF 10G and RUGOSURF 90G to PC (connector v3) |
| 058213 | Connecting cable RUGOSURF 20 to dot matrix printer |
| 056109 | Connecting cable RUGOSURF 10G and RUGOSURF 90G to dot matrix printer |

Calipers



THE ESSENTIALS

Calipers are the most popular length measuring instruments used worldwide. Owing to their simple construction, ease of handling and quick operation, they are a favourite for dimensional measurement. The wide variety of models available with specialised measuring faces make them universal hand-held tools.

All TESA, ETALON, INTERAPID branded calipers are recognised for their superior quality – and guarantee you precise measurement. The flawless guide of the slider on the beam ensures silky-smooth operation whilst also preventing the measuring jaws from tilting.

The choice of material, subjected to precisely defined heat treatment as well as a robust design result in further distinctive advantages such as wear and corrosion resistance.

For quick and easy reading of measured values – one of the essential conditions for the assurance of your measurements – we offer conventional vernier models as well as dial models for easy reading and digital models for error-free reading.

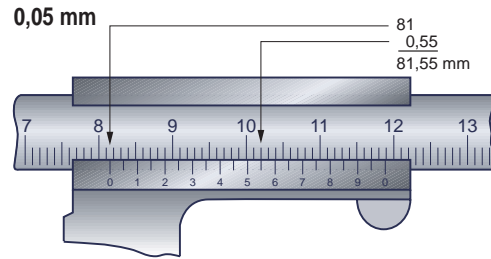
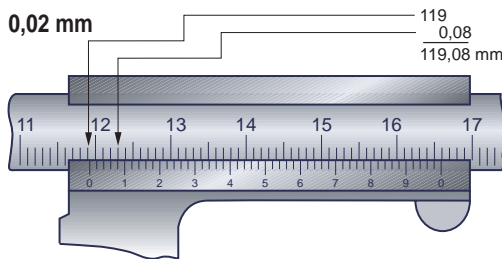

| Chosen Length L mm | 0,1 mm 0,05 mm µm | 0,02 mm µm | 0,01 mm µm |
|-----------------------|-------------------------|---------------|---------------|
| 50 | 50 | 20 | 20 |
| 100 | 50 | 20 | 20 |
| 150 | 50 | 30 | 30 |
| 300 | 50 | 30 | 30 |
| 400 | 60 | 30 | 30 |
| 500 | 70 | 30 | 30 |
| 600 | 80 | 30 | 30 |
| 700 | 90 | 40 | 40 |
| 800 | 100 | 40 | 40 |
| 900 | 110 | 40 | 40 |
| 1000 | 120 | 40 | 40 |
| 1200 | 140 | 50 | |
| 1400 | 160 | 50 | |
| 1600 | 180 | 60 | |
| 1800 | 200 | 60 | |
| 2000 | 220 | 60 | |

The max. permissible errors (G) are expressed by the equation given below, where the values should be rounded down to two decimal fractions (0,01 mm). These errors apply for measurements taken under the same measuring force. For all other measurements, including those performed with use of the depth foot, the values obtained have to be increased by 20 µm.

Calipers with dial or vernier reading to 0,1 or 0,05 mm :
 $G = (20 + l / 10 \text{ mm}) \mu\text{m} \geq 50 \mu\text{m}$

Calipers with analogue indication (scale or vernier reading to 0,02 mm) or digital indication :
 $G = (22 + l / 50 \text{ mm}) \mu\text{m}$

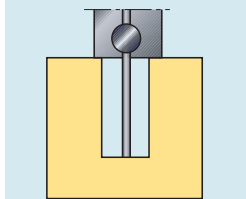
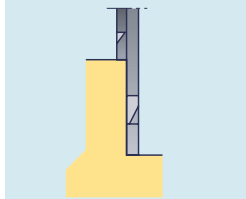
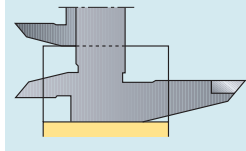
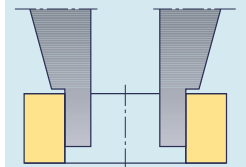
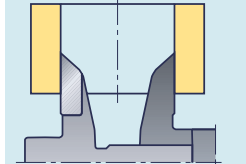
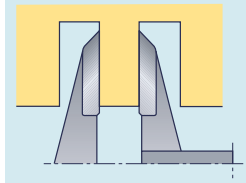
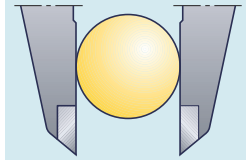

- +
- ISO 13385-1
- 0,01 mm / 0.0005 in
- LCD, 11 mm
- Floating zero
- mm / in conversion
- ≤ 100 mm: 20 µm
≥ 100 mm: 30 µm
- 10 µm
- Scale with incremental divisions, inductive
- 2,5 m/s
- TLC Connectivity
- Stainless steel
- Lithium battery, 3V, CR2032
- 12.000 hours
- Standby mode after 10 minutes, instrument retains the zero position. Automatic shut off after 2 hours, instrument retains the zero in ABS mode, but the zero must be reset if the instrument is in DIFF mode.
- 10°C to 60°C
- 10°C to 40°C
- 100 %
- IP67
- 1907/2006/CE
2004/108/CE
2002/96/CE
- Plastic storage case
- Inspection report and declaration of conformity
- Serial number identification

TWIN-CAL IP67

Welcome to the new generation of TESA electronic calipers, with the highest degree of protection ever offered.

The TWIN-CAL IP67 are all equipped with TLC (TESA Link Connector), the unique integral data output facility, providing the opportunity to upgrade your caliper at any time.

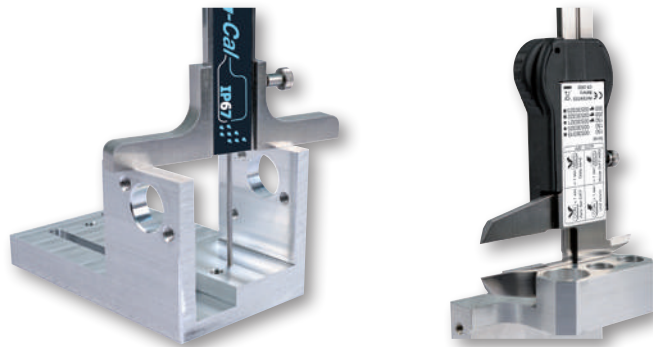

| No | mm | in | Drive system / Thumb Roller | A mm | B mm | C mm | g | Depth rod |
|----------|-----|----|-----------------------------|------|------|------|-----|-----------|
| 00530319 | 150 | 6 | – | 40 | 16 | 74 | 150 | Square |
| 00530320 | 150 | 6 | – | 40 | 16 | 74 | 150 | Round |
| 00530321 | 150 | 6 | With | 40 | 16 | 74 | 150 | Round |
| 00530322 | 200 | 8 | With | 50 | 20 | 90 | 200 | Square |
| 00530323 | 300 | 12 | With | 64 | 22 | 106 | 280 | Square |

OPTIONAL ACCESSORIES:

- 00560013 Depth foot for calipers up to 150 mm
- 01961000 Lithium battery, 3V, CR2032
- 04760180 TESA TLC-TWIN wireless emitter-receiver
Compatible with any instrument fitted with a TLC – TESA Link Connector
- 04760181 TESA TLC-USB cable for instruments with a TLC connector
- 04760182 TLC-DIGIMATIC cable for instruments with a TLC connector



TWIN-CAL IP40

The new TWIN-CAL calipers are all supplied with a built in data output port. Simply plug the TESA TLC connector into the TWIN-CAL and the other end into a PC and all your measurement results will be captured and stored for optimal SPC monitoring.



| No | mm | in | Drive system / Thumb roller | A mm | B mm | C mm | g | Depth rod |
|----------|-----|----|-----------------------------|------|------|------|-----|-----------|
| 00530094 | 150 | 6 | With | 40 | 16 | 74 | 150 | Round |
| 00530097 | 150 | 6 | - | 40 | 16 | 74 | 150 | Square |
| 00530095 | 200 | 8 | With | 50 | 20 | 90 | 200 | Square |
| 00530096 | 300 | 12 | With | 64 | 22 | 106 | 280 | Square |

OPTIONAL ACCESSORIES:

| | |
|----------|---|
| 00560013 | Depth foot for calipers up to 150 mm |
| 01961000 | Lithium battery, 3V, CR2032 |
| 04760180 | TESA TLC-TWIN wireless emitter-receiver Compatible with any instrument fitted with a TLC – TESA Link Connector |
| 04760181 | TESA TLC-USB cable for instruments with a TLC connector |
| 04760182 | TLC-DIGIMATIC cable for instruments with a TLC connector |

- ISO 13385-1
- 0,01 mm / 0.0005 in
- LCD, 11 mm
- Floating zero
- mm/in conversion
- ≤ 100 mm: 20 µm
>100 mm: 30 µm
- 10 µm
- Scale with incremental divisions, inductive
- 2,5 m/s
- TLC connectivity
- Stainless steel
- 3V Lithium battery, CR2032
- 12.000 hours
- Standby mode after 10 minutes, instrument retains zero. Automatic shut off after 2 hours. The instrument retains zero in ABS mode, but if the instrument is in DIFF mode, the zero must be reset.
- 10°C to 60°C
- 10°C to 40°C
- 80 %
- IP40
- 1907/2006/CE
2004/108/CE
2002/96/CE
- Plastic storage case
- Inspection report with declaration of conformity
- Serial number identification

TESA VALUELINE IP40

TESA VALUELINE, a brand designed by TESA to meet the demands of users looking for affordable products, but not willing to compromise on TESA know-how. The Swiss technology at the heart of our products offers additional quality assurance.

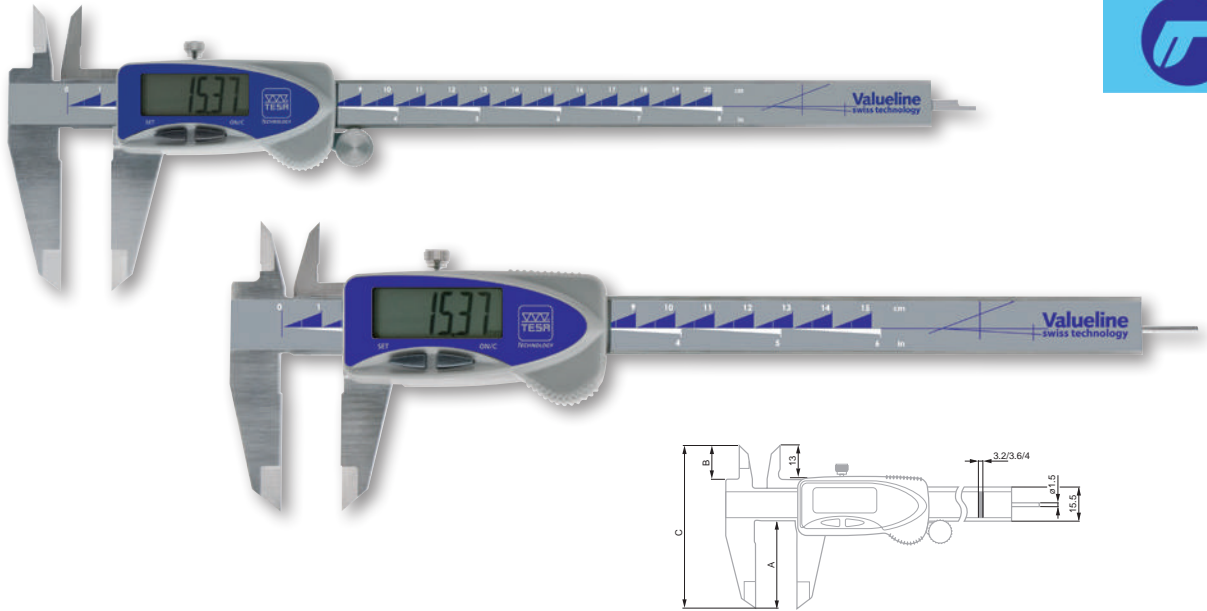

- ISO 13385-1
- 0,01 mm / 0.0005 in
- LCD, 11 mm
- Floating zero
- mm / in conversion
- ≤ 100 mm = 20 μm
>100 mm = 30 μm
- 10 μm
- Scale with incremental divisions, capacitive
- 1,6 m/s
- Stainless steel
- 3V Lithium battery, CR2032
- 1.5 to 2 years
- Standby mode after 10 minutes, instrument retains zero. Automatic shut off after 2 hours. The instrument retains zero in ABS mode, but if the instrument is in DIFF mode, the zero must be reset.
- 10°C to 60°C
- 10°C to 40°C
- 80 %
- IP40
- 1907/2006/CE
2004/108/CE
2002/96/CE
- Plastic storage case
- Inspection report with declaration of conformity
- Serial number identification

| No | mm | in | Drive system/ thumb roller | A mm | B mm | C mm | g | Depth rod |
|------------------------------|--------------------------------------|----|-------------------------------|------|------|------|-----|-----------|
| 00539090 | 150 | 6 | – | 40 | 16 | 74 | 150 | Square |
| 00539091 | 150 | 6 | – | 40 | 16 | 74 | 150 | Round |
| 00539092 | 200 | 8 | With | 50 | 20 | 90 | 200 | Square |
| 00539093 | 300 | 12 | With | 64 | 22 | 106 | 280 | Square |
| OPTIONAL ACCESSORIES: | | | | | | | | |
| 01961000 | Lithium battery, 3V, CR2032 | | | | | | | |
| 00560013 | Depth foot for calipers up to 150 mm | | | | | | | |



DIAL CALIPERS

Rugged construction – High accuracy – Patented shockproof design – Ideal for use in the workshop.

Models TESA CCMA-M

Easy-to-read dial calipers – Slider with metal dial housing – Models with a 200 or 300 measuring span are fitted with a thumb roller.

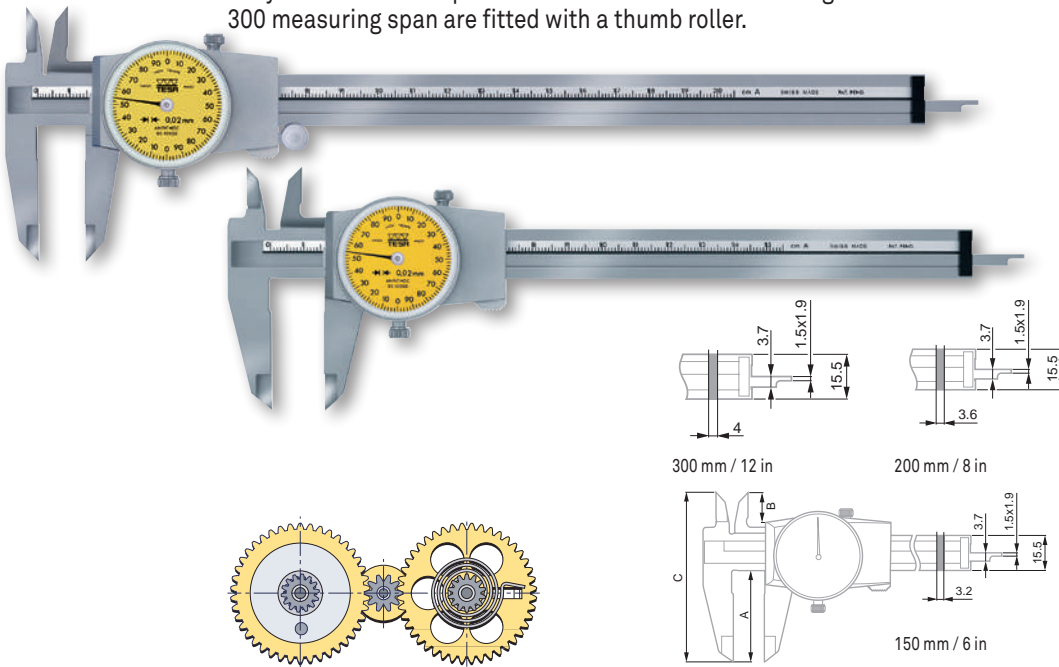

| | Thumb roller | A mm | B mm | C mm | | | |
|----------|--------------|----------|--------|------|----|------|-------|
| 00510008 | 0 ÷ 150 mm | 0,02 mm | 2 mm | – | 40 | 13 | 74 |
| 00520002 | 0 ÷ 6 in | 0,001 in | 0,1 in | – | 40 | 13 | 74 |
| 00510045 | 0 ÷ 200 mm | 0,02 mm | 2 mm | ● | 50 | 18,6 | 89,5 |
| 00510046 | 0 ÷ 300 mm | 0,02 mm | 2 mm | ● | 64 | 20,6 | 105,5 |

OPTIONAL ACCESSORY:
00560013 Depth foot for calipers up to 150 mm

Model TESA CCMA-M, 0,01 mm

Slider with metal dial housing – 1 mm per dial revolution.

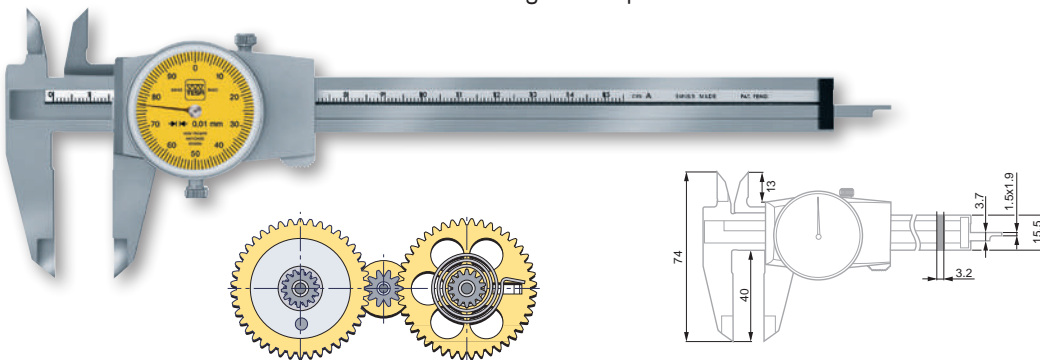

| | mm | mm | mm | |
|----------|------------|------|------|--|
| 00510050 | 0 ÷ 150 mm | 0,01 | 1 mm | |

OPTIONAL ACCESSORY:
00560013 Depth foot for calipers up to 150 mm

- DIN 862 (Style 1AR)
- ≤ 100 mm = 20 µm
>100 mm = 30 µm
- Gear mechanism made of hardened ground steel
- Hardened stainless steel
- Plastic storage case
- Inspection report with a declaration of conformity
- Serial number identification
- 32 mm diameter rotating dial with lock
- Slider with locking screw
- Patented shockproof design

-
- DIN 862 (Style 1AR)
- ≤ 100 mm = 20 µm
>100 mm = 30 µm
- Gear mechanism made of hardened ground steel
- Hardened stainless steel
- Plastic storage case
- Inspection report with a declaration of conformity
- Serial number identification
- 32 mm diameter rotating dial with lock
- Slider with locking screw
- Patented shockproof design



N DIN 862 (Style 1AR)

≤ 100 mm = 20 μm
>100 mm = 30 μm

Gear mechanism made of hardened, ground steel

Hardened stainless steel

Plastic storage case

Inspection report with a declaration of conformity

No Serial number identification

32 mm diameter rotating dial with lock

A Slider with plastic dial housing and locking screw

Patented shockproof design

TESA CCMA-P Models

Quick and easy to read – Slider with plastic dial housing.

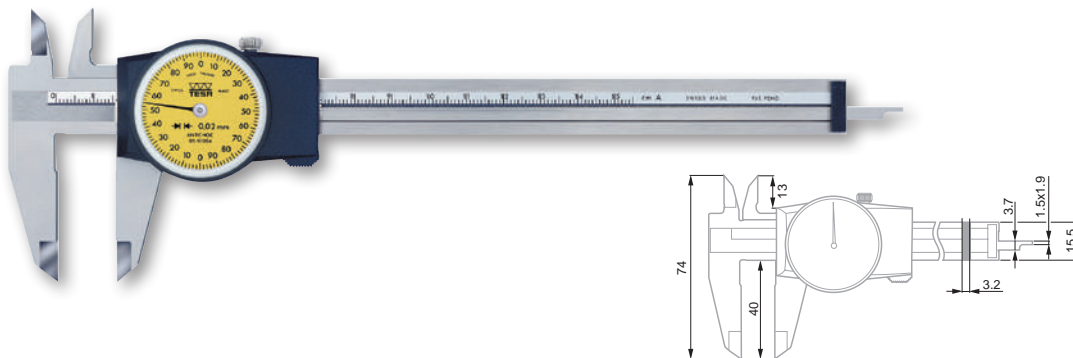

| | | | | |
|----------|------------|----------|--------|---------------------|
| 00510004 | 0 ÷ 150 mm | 0,02 mm | 2 mm | Without thumb wheel |
| 00520001 | 0 ÷ 6 in | 0.001 in | 0.1 in | Without thumb wheel |

OPTIONAL ACCESSORY:

00560013 Depth foot for calipers up to 150 mm



N DIN 862 (Style 1AR)

≤ 100 mm = 20 μm
>100 mm = 30 μm

Gear mechanism made of hardened, ground steel

Hardened stainless steel

Plastic storage case

Inspection report with a declaration of conformity

No Serial number identification

32 mm diameter rotating dial with lock

A Slider with locking screw

Patented shockproof design

ETALON 125 Model

Slider with metal dial housing – 1 mm travel per dial revolution.

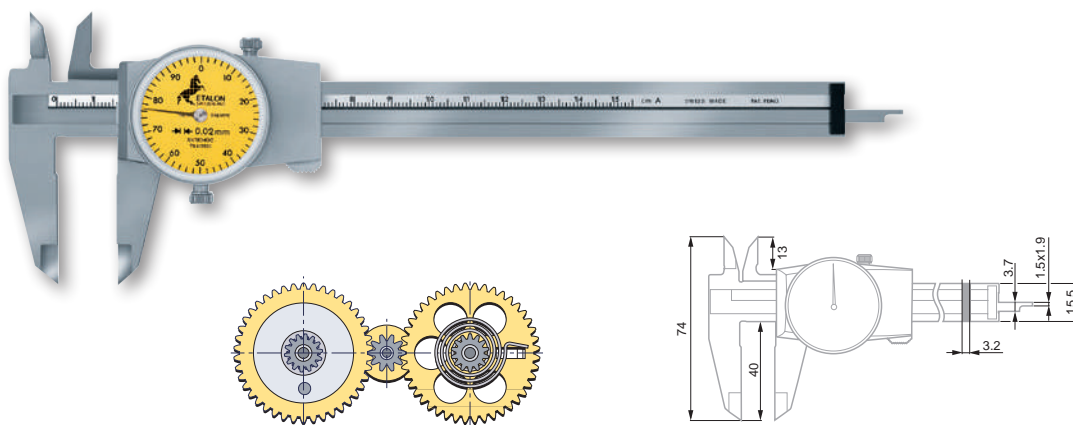

| | | | | |
|-----------|------------|---------|------|---------------------|
| 075115821 | 0 ÷ 150 mm | 0,02 mm | 1 mm | Without thumb wheel |
|-----------|------------|---------|------|---------------------|

OPTIONAL ACCESSORY:

00560013 Depth foot for calipers up to 150 mm





ACCESSORIES FOR CALIPERS

Accessories for standard calipers

Depth Measuring Foot

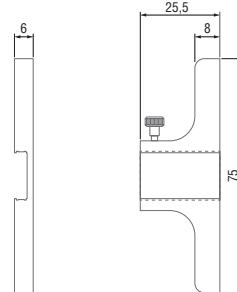
For use with TESA or ETALON universal calipers with a measuring span of 0 to 150 mm / 0 to 6 inch.



| | | |
|-----------|--------------------------------------|---|
| No | = |  |
| 00560013 | Depth foot for calipers up to 150 mm | mm 75 x 6 |



Factory standard



Hardened stainless steel



Ground measuring face

Magnetic Magnifying Glass

Can be mounted on calipers and other such instruments for easier reading of vernier scales.



| | | |
|------------|---|--|
| No | = | |
| 0051610365 | Magnetic magnifying glass, 3x magnification | |



Plastic pouch



2 permanent magnets



DIN 862
(Style 1AN-2)
NFE 11-091

Maximum
permissible errors,
in accordance with
standard

Hardened stainless
steel

Plastic storage
case

Inspection report
with a declaration
of conformity

Serial number
identification

Satin-chrome scale
background; main
scale slightly set
back for protection
against wear

VERNIER CALIPERS

The simplest calipers to use with engraved scales for reading very fine divisions on measurements.

Standard Models

Calipers offering great value for money:

- Fitted with a locking screw.
- With rectangular or round depth rod.

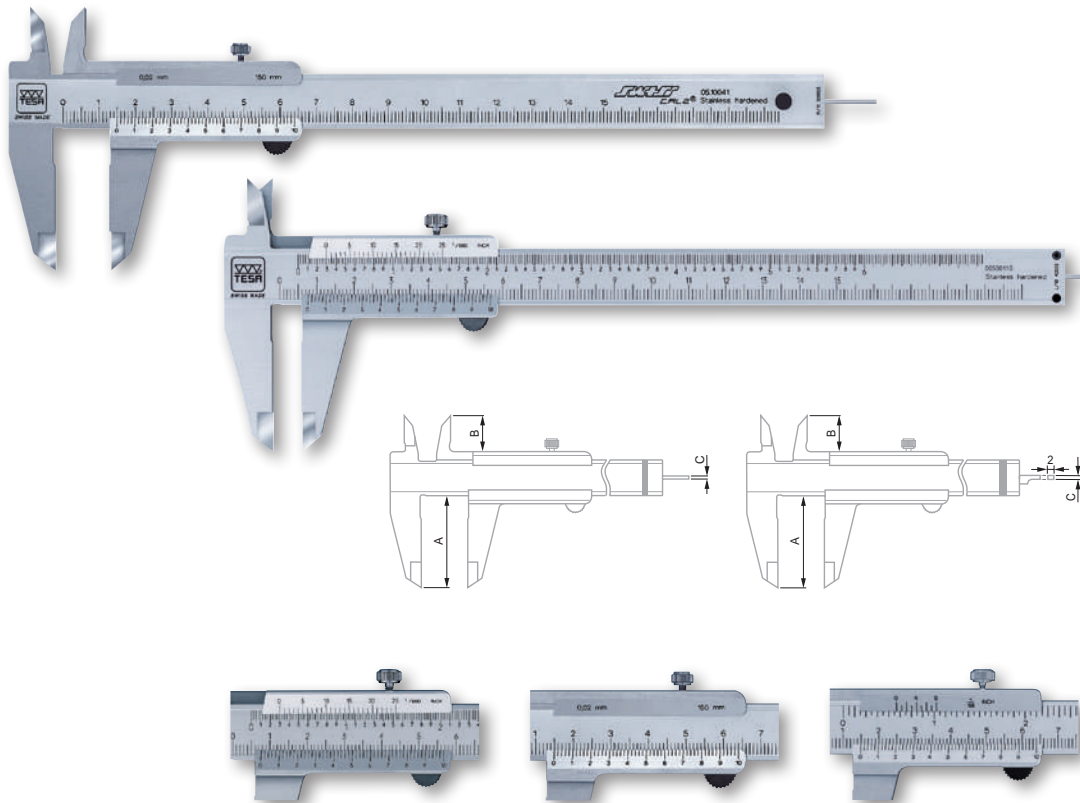

| No | Symbol | mm | in | mm | in | A mm | B mm | C mm |
|----------|--|---------|--------|------|-------|------|------|---------|
| 00510041 | SWISSCAL 2 | 0 ÷ 150 | - | 0,02 | - | 40 | 15,5 | Ø 1,5 |
| 00510047 | Standard | 0 ÷ 150 | - | 0,05 | - | 40 | 15,5 | Ø 1,5 |
| 00530103 | Standard | 0 ÷ 150 | 0 ÷ 6 | 0,05 | 1/128 | 40 | 15,5 | Ø 1,5 |
| 00530104 | Standard | 0 ÷ 200 | 0 ÷ 8 | 0,05 | 1/128 | 50 | 18 | 1,5 x 2 |
| 00530105 | Standard | 0 ÷ 300 | 0 ÷ 12 | 0,05 | 1/128 | 64 | 22 | - |
| 00530110 | Standard | 0 ÷ 150 | 0 ÷ 6 | 0,02 | 0.001 | 40 | 15,5 | Ø 1,5 |
| 00530111 | Standard | 0 ÷ 200 | 0 ÷ 8 | 0,02 | 0.001 | 50 | 18 | 1,5 x 2 |
| 00530112 | Standard | 0 ÷ 300 | 0 ÷ 12 | 0,02 | 0.001 | 64 | 22 | - |
| 00530120 | Self-locking model | 0 ÷ 150 | 0 ÷ 6 | 0,05 | 1/128 | 40 | 15,5 | 1,5 x 2 |
| 00530121 | Self-locking model | 0 ÷ 150 | 0 ÷ 6 | 0,02 | 0.001 | 40 | 15,5 | 1,5 x 2 |
| 00530130 | Self-locking model with parallax-free readout | 0 ÷ 150 | 0 ÷ 6 | 0,05 | 1/128 | 40 | 15,5 | 1,5 x 2 |
| 00530131 | Self-locking model with parallax-free readout | 0 ÷ 150 | 0 ÷ 6 | 0,02 | 0.001 | 40 | 15,5 | 1,5 x 2 |

OPTIONAL ACCESSORIES:

00560013 Depth foot for calipers up to 150 mm

0051610365 Magnetic magnifying glass, 3x magnification



WORKSHOP DIGITAL CALIPERS

The range of IP67 calipers guarantees the highest level of protection against the penetration of dust and liquids. The TLC (TESA Link Connector) system built into all the TwinCal calipers provides the connection of these instruments to a PC for the easy acquisition of measurement data. The unique display housing, protected by a steel plate surrounded with a rubber seal guarantees durability and offers fine sensitivity during measurement.

TWIN-CAL IP67 – Models with Rounded Measuring Faces for Internal Dimensions

- Complete IP67 protection against the penetration of dust and liquids, even when the cable is connected.
- Unique TWIN connectivity concept allowing for upgrade across the range.

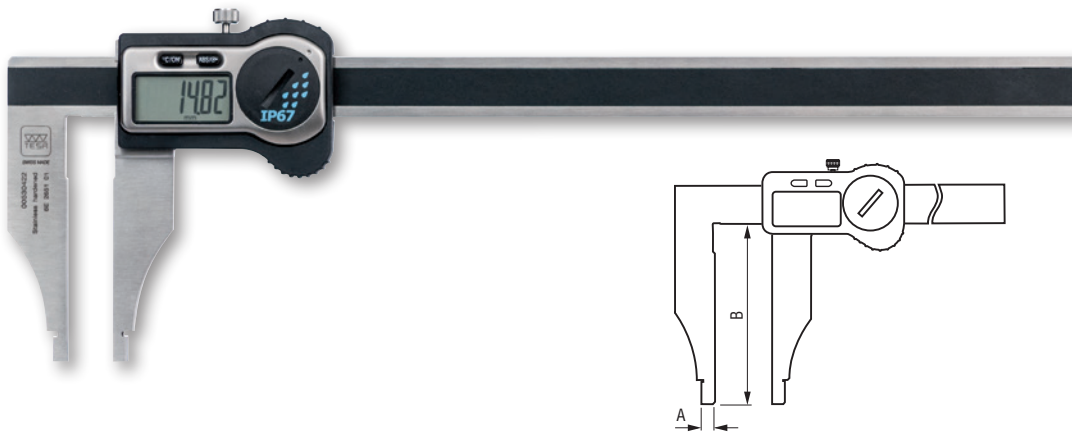

| No | mm | in | A mm | B mm |
|----------|------|----|------|------|
| 00530421 | 200 | 8 | 5 | 80 |
| 00530422 | 250 | 10 | 5 | 80 |
| 00530423 | 300 | 12 | 5 | 90 |
| 00530424 | 500 | 20 | 10 | 150 |
| 00530425 | 600 | 24 | 10 | 150 |
| 00530426 | 800 | 32 | 10 | 150 |
| 00530427 | 1000 | 40 | 10 | 150 |

OPTIONAL ACCESSORIES:

| | |
|----------|---|
| 01961000 | Lithium battery, 3V, CR2032 |
| 04760180 | TESA TLC-TWIN wireless emitter-receiver Compatible with any instrument fitted with a TLC – TESA Link Connector |
| 04760181 | TESA TLC-USB cable for instruments with a TLC connector |
| 04760182 | TLC-DIGIMATIC cable for instruments with a TLC connector |

- ISO 13385-1
- 0,01 mm / 0.0005 in
- LCD, 11 mm
- Floating zero
- mm / in conversion
- L ≤ 100 mm: 20 µm
100 < L ≤ 600 mm: 30 µm
600 < L ≤ 1000 mm: 40 µm
- 10 µm
- Scale with incremental divisions, inductive
- 2,5 m/s
- TLC Connectivity
- Stainless steel
- 3V Lithium battery, CR2032
- 12.000 hours
- Standby mode after 10 minutes, instrument retains the zero position. Automatic shut off after 2 hours, instrument retains the zero in ABS mode, but the zero must be reset if the instrument is in DIFF mode.
- 10°C to 60°C
- 10°C to 40°C
- 100 %
- IP67
- 1907/2006/CE
2004/108/CE
2002/96/CE
- Plastic storage case
- Inspection report with declaration of conformity
- Serial number identification

- ISO 13385-1
- 0,01 mm / 0.0005 in
- LCD, 11 mm
- Floating zero
- mm / in conversion
- L ≤ 100 mm: 20 µm
100 < L ≤ 600 mm: 30 µm
600 < L ≤ 1000 mm: 40 µm
- 10 µm
- Scale with incremental divisions, inductive
- 2,5 m/s
- TLC Connectivity
- Stainless steel
- 3V Lithium battery, CR2032
- 12.000 hours
- Standby mode after 10 minutes, instrument retains the zero position. Automatic shut off after 2 hours, instrument retains the zero in ABS mode, but the zero must be reset if the instrument is in DIFF mode.
- 10°C to 60°C
- 10°C to 40°C
- 100 %
- IP67
- 1907/2006/CE
2004/108/CE
2002/96/CE
- Plastic storage case
- Inspection report with declaration of conformity
- Serial number identification

TWIN-CAL IP67 – Models with Rounded Measuring Faces for Internal Dimensions and Knife-edge Jaws

- Complete IP67 protection against the penetration of dust and liquids, even when the cable is connected
- Unique TWIN connectivity concept allowing for upgrade across the range.

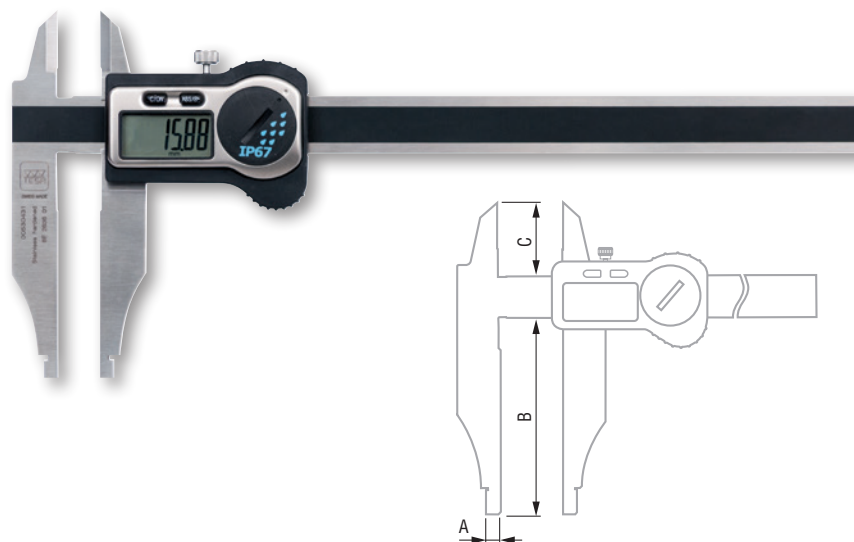

| No | | | | | |
|----------|------|----|----|-----|----|
| 00530431 | 200 | 8 | 5 | 80 | 30 |
| 00530432 | 250 | 10 | 5 | 80 | 37 |
| 00530433 | 300 | 12 | 5 | 90 | 37 |
| 00530434 | 500 | 20 | 10 | 150 | 60 |
| 00530435 | 600 | 24 | 10 | 150 | 60 |
| 00530436 | 800 | 32 | 10 | 150 | 56 |
| 00530437 | 1000 | 40 | 10 | 150 | 56 |

OPTIONAL ACCESSORIES:

| | |
|----------|---|
| 01961000 | Lithium battery, 3V, CR2032 |
| 04760180 | TESA TLC-TWIN wireless emitter-receiver Compatible with any instrument fitted with a TLC – TESA Link Connector |
| 04760181 | TESA TLC-USB cable for instruments with a TLC connector |
| 04760182 | TLC-DIGIMATIC cable for instruments with a TLC connector |



TWIN-CAL IP67 – Models with Rounded Measuring Faces for Internal Dimensions and Knife-edge Jaws for External Dimensions

- Complete IP67 protection against the penetration of dust and liquids, even when the cable is connected
- Unique TWIN connectivity concept allowing for upgrade across the range.

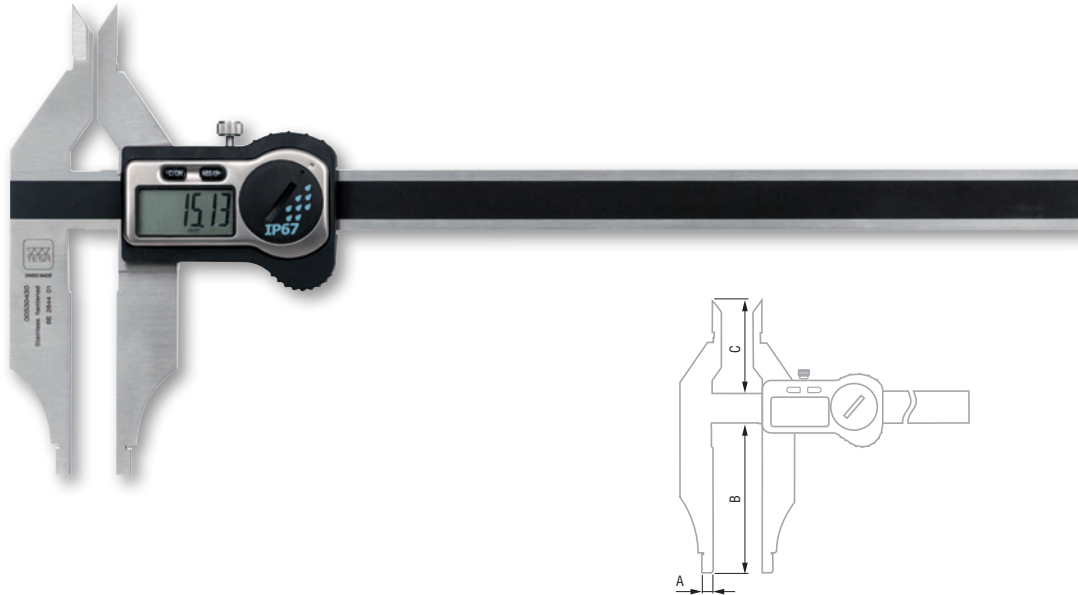

| No | mm | in | A mm | B mm | C mm |
|----------|-----|----|------|------|------|
| 00530430 | 250 | 10 | 5 | 80 | 54 |

OPTIONAL ACCESSORIES:

| | |
|----------|---|
| 01961000 | Lithium battery, 3V, CR2032 |
| 04760180 | TESA TLC-TWIN wireless emitter-receiver Compatible with any instrument fitted with a TLC – TESA Link Connector |
| 04760181 | TESA TLC-USB cable for instruments with a TLC connector |
| 04760182 | TLC-DIGIMATIC cable for instruments with a TLC connector |

- ISO 13385-1
- 0,01 mm / 0.0005 in
- LCD, 11 mm
- Floating zero
- mm / in conversion
- L ≤ 100 mm: 20 µm
100 < L ≤ 250 mm: 30 µm
- 10 µm
- Scale with incremental divisions, inductive
- 2,5 m/s
- TLC Connectivity
- Stainless steel
- 3V Lithium battery, CR2032
- 12.000 hours
- Standby mode after 10 minutes, instrument retains the zero position. Automatic shut off after 2 hours, instrument retains the zero in ABS mode, but the zero must be reset if the instrument is in DIFF mode.
- 10°C to 60°C
- 10°C to 40°C
- 100 %
- IP67
- 1907/2006/CE
2004/108/CE
2002/96/CE
- Plastic storage case
- Inspection report with declaration of conformity
- Serial number identification



DIN 862
(Style EN-2)
NFE 11-091



Maximum permissible errors in accordance with standard



Hardened stainless steel



Plastic or wooden storage case depending on the size of the model



Inspection report with a declaration of conformity



Serial number identification



Satin-chrome scale background; main scale set back slightly for protection against wear.

VERNIER CALIPERS

The simplest calipers to use with engraved scales for reading very fine divisions on measurements.

Models with Rounded Measuring Faces for Internal Dimensions (Without Fine Adjust Device)

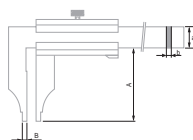
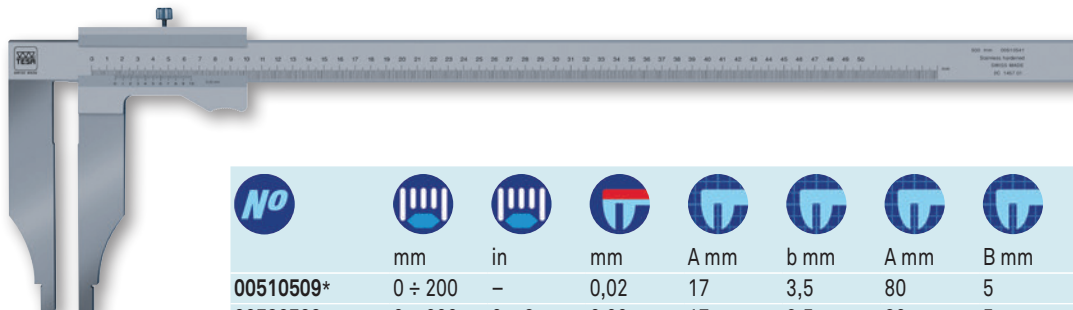

| No | | | | | | | |
|-----------|---------|--------|------|------|------|------|------|
| | mm | in | mm | A mm | b mm | A mm | B mm |
| 00510509* | 0 ÷ 200 | – | 0,02 | 17 | 3,5 | 80 | 5 |
| 00530509 | 0 ÷ 200 | 0 ÷ 8 | 0,02 | 17 | 3,5 | 80 | 5 |
| 00510506 | 0 ÷ 200 | – | 0,05 | 17 | 3,5 | 80 | 5 |
| 00510511 | 0 ÷ 250 | – | 0,02 | 20 | 4 | 90 | 5 |
| 00510512 | 0 ÷ 250 | – | 0,05 | 20 | 4 | 90 | 5 |
| 00510521 | 0 ÷ 300 | – | 0,02 | 20 | 4 | 90 | 5 |
| 00530521 | 0 ÷ 300 | 0 ÷ 12 | 0,02 | 20 | 4 | 90 | 5 |
| 00510522 | 0 ÷ 300 | – | 0,05 | 20 | 4 | 90 | 5 |
| 00510531 | 0 ÷ 400 | – | 0,02 | 24,5 | 5 | 125 | 10 |
| 00530531 | 0 ÷ 400 | 0 ÷ 15 | 0,02 | 24,5 | 5 | 125 | 10 |
| 00510541 | 0 ÷ 500 | – | 0,02 | 28 | 6 | 150 | 10 |
| 00510542 | 0 ÷ 500 | – | 0,05 | 28 | 6 | 150 | 10 |
| 00510551 | 0 ÷ 600 | – | 0,02 | 28 | 6 | 150 | 10 |

OPTIONAL ACCESSORY:

0051610365 Magnetic magnifying glass, 3x magnification

* Supplied with a flexible stainless steel rule, 200 mm long, part code 0951750181



DIN 862
(Style EN-2F)
NFE 11-091



Maximum permissible errors in accordance with standard



Hardened stainless steel



Plastic or wooden storage case, depending on the model



Inspection report with a declaration of conformity



Serial number identification



Satin-chrome scale background; main scale set back slightly for protection against wear

Models with Rounded Measuring Faces (With Fine Adjust Device)

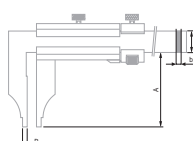
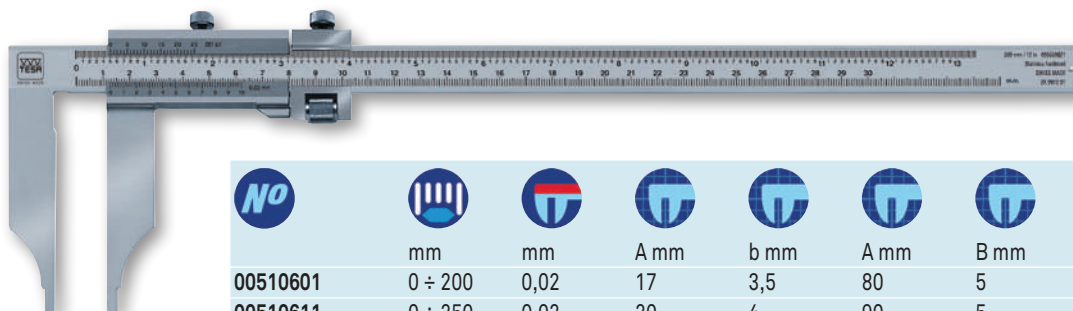

| No | | | | | | |
|----------|----------|------|------|------|------|------|
| | mm | mm | A mm | b mm | A mm | B mm |
| 00510601 | 0 ÷ 200 | 0,02 | 17 | 3,5 | 80 | 5 |
| 00510611 | 0 ÷ 250 | 0,02 | 20 | 4 | 90 | 5 |
| 00510621 | 0 ÷ 300 | 0,02 | 20 | 4 | 90 | 5 |
| 00510641 | 0 ÷ 500 | 0,02 | 28 | 6 | 150 | 10 |
| 00510651 | 0 ÷ 600 | 0,02 | 28 | 6 | 150 | 10 |
| 00510661 | 0 ÷ 800 | 0,02 | 32 | 8 | 150 | 10 |
| 00510671 | 0 ÷ 1000 | 0,02 | 32 | 8 | 150 | 10 |
| 00510681 | 0 ÷ 1500 | 0,02 | 40 | 8 | 300 | 15 |
| 00510691 | 0 ÷ 2000 | 0,02 | 40 | 8 | 300 | 15 |

OPTIONAL ACCESSORY:

0051610365 Magnetic magnifying glass, 3x magnification



Models with Knife-edge Jaws for External Dimensions and Rounded Measuring Faces for Internal Dimensions (Without Fine Adjust Device)

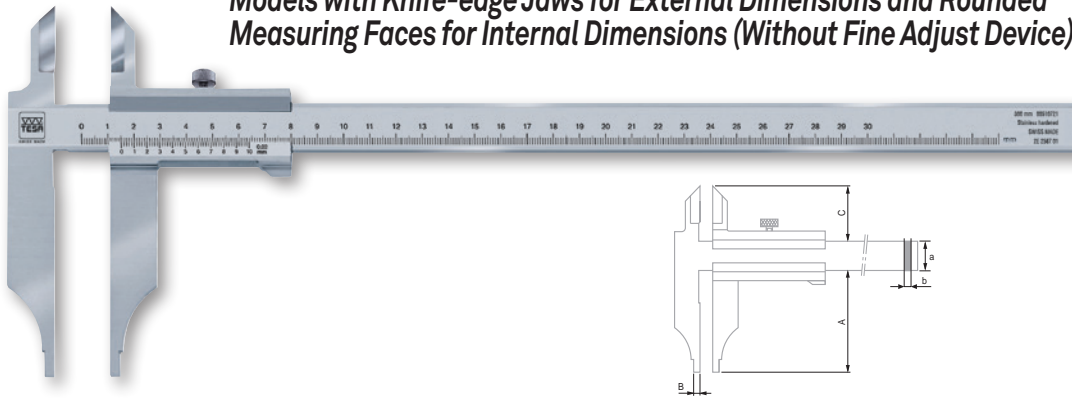

| No | mm | in | mm | A mm | b mm | A mm | B mm | C mm |
|----------|---------|--------|------|------|------|------|------|------|
| 00510701 | 0 ÷ 200 | – | 0,02 | 17 | 3,5 | 80 | 5 | 30 |
| 00530701 | 0 ÷ 200 | 0 ÷ 8 | 0,02 | 17 | 3,5 | 80 | 5 | 30 |
| 00510711 | 0 ÷ 250 | – | 0,02 | 20 | 4 | 80 | 5 | 38 |
| 00510721 | 0 ÷ 300 | – | 0,02 | 20 | 4 | 90 | 5 | 38 |
| 00530721 | 0 ÷ 300 | 0 ÷ 12 | 0,02 | 20 | 4 | 90 | 5 | 38 |
| 00510722 | 0 ÷ 300 | – | 0,05 | 20 | 4 | 90 | 5 | 38 |
| 00510741 | 0 ÷ 500 | – | 0,02 | 28 | 6 | 150 | 10 | 60 |
| 00530741 | 0 ÷ 500 | 0 ÷ 20 | 0,02 | 28 | 6 | 150 | 10 | 60 |
| 00510751 | 0 ÷ 600 | – | 0,02 | 28 | 6 | 150 | 10 | 60 |

OPTIONAL ACCESSORY:

0051610365 Magnetic magnifying glass, 3x magnification

Models with Knife-edge Jaws for External Dimensions and Rounded Measuring Faces for Internal Dimensions (With Fine Adjust Device)

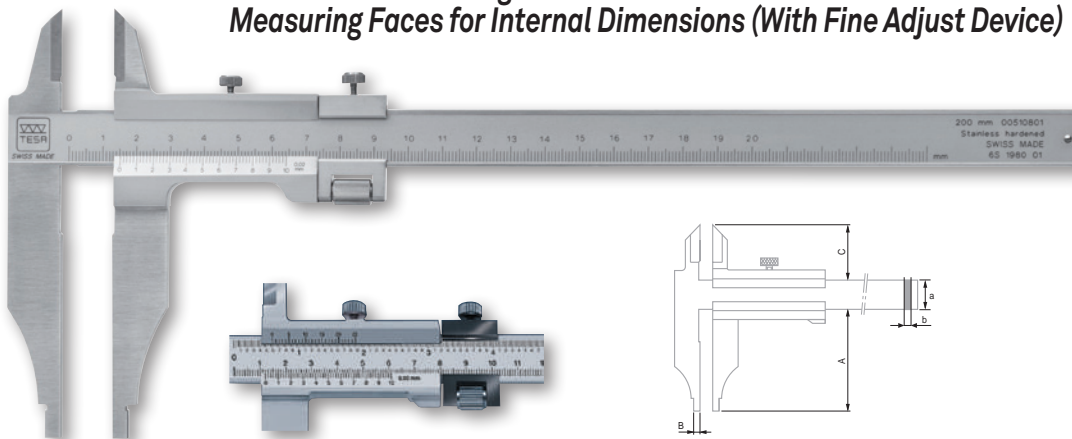

| No | mm | in | mm | A mm | b mm | A mm | B mm | C mm |
|----------|----------|--------|------|------|------|------|------|------|
| 00510801 | 0 ÷ 200 | – | 0,02 | 17 | 3,5 | 80 | 5 | 30 |
| 00510821 | 0 ÷ 300 | – | 0,02 | 20 | 4 | 90 | 5 | 38 |
| 00530821 | 0 ÷ 300 | 0 ÷ 11 | 0,02 | 20 | 4 | 90 | 5 | 38 |
| 00510822 | 0 ÷ 300 | – | 0,05 | 20 | 4 | 90 | 5 | 38 |
| 00510841 | 0 ÷ 500 | – | 0,02 | 28 | 6 | 150 | 10 | 60 |
| 00530841 | 0 ÷ 500 | 0 ÷ 20 | 0,02 | 28 | 6 | 150 | 10 | 60 |
| 00510861 | 0 ÷ 800 | – | 0,02 | 32 | 8 | 150 | 10 | 56 |
| 00510871 | 0 ÷ 1000 | – | 0,02 | 32 | 8 | 150 | 10 | 56 |

OPTIONAL ACCESSORY:

0051610365 Magnetic magnifying glass, 3x magnification



DIN 862
(Style BN-2)
NFE 11-091



Maximum permissible errors, in accordance with standard



Hardened stainless steel



Plastic or wooden storage case depending on size of the model



Inspection report with a declaration of conformity



Serial number identification



Satin-chrome scale background: main scale set back slightly for protection against wear



DIN 862
(Style BN-2)
NFE 11-091



Maximum permissible errors in accordance with standard



Hardened stainless steel



Plastic or wooden storage case depending on size of the model



Inspection report with a declaration of conformity



Serial number identification



Satin-chrome scale background: main scale set back slightly for protection against wear

- +
- ISO 13385-1
- 0,01 mm / 0.0005 in
- LCD, 11 mm
- Floating zero
- mm / in conversion
- L ≤ 100 mm: 20 μm
100 < L ≤ 600 mm: 30 μm
600 < L ≤ 1000 mm: 40 μm
- 10 μm
- Scale with incremental divisions, inductive
- 2,5 m/s
- TLC Connectivity
- Stainless steel
- 3V lithium battery, CR2032
- 12.000 hours
- Standby mode after 10 minutes, instrument retains the zero position. Automatic shut off after 2 hours, instrument retains the zero in ABS mode, but the zero must be reset if the instrument is in DIFF mode.
- 10°C to 60°C
- 10°C to 40°C
- 100 %
- IP67
- 1907/2006/CE
2004/108/CE
2002/96/CE
- Plastic storage case
- Inspection report with declaration of conformity
- Serial number identification

DIGITAL DEPTH CALIPERS

The range of IP67 calipers guarantees the highest level of protection against the penetration of dust and liquids. The TLC (TESA Link Connector) system built into all the TWIN-CAL calipers provides the connection of these instruments to a PC for the easy acquisition of measurement data. The unique display housing, protected by a steel plate surrounded with a rubber seal guarantees durability and offers fine sensitivity during measurement.

TWIN-CAL IP67 – Models with Short Cut Measuring Face

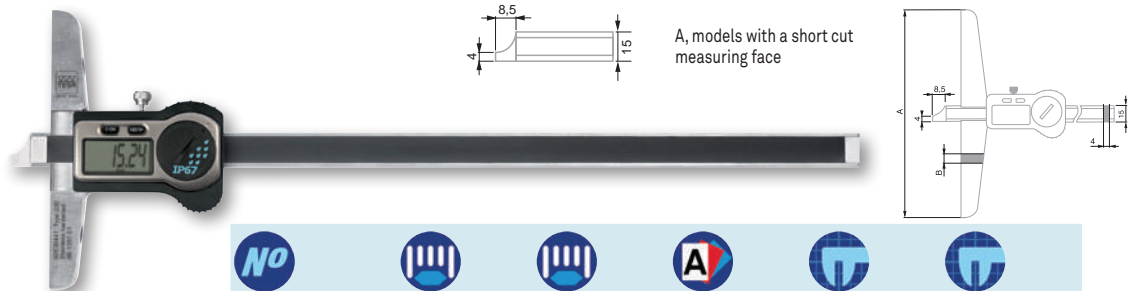

| No | | | Models | | |
|----------|-----|----|--------|-----|---|
| 00530441 | 200 | 8 | A | 100 | 8 |
| 00530442 | 250 | 10 | A | 100 | 8 |
| 00530443 | 300 | 12 | A | 150 | 8 |
| 00530444 | 500 | 20 | A | 150 | 8 |

TWIN-CAL IP67 – Models with One Fixed Measuring Jaw

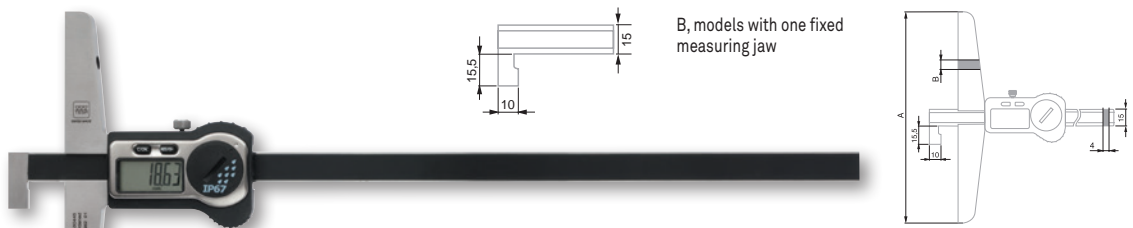

| No | | | Models | | |
|----------|-----|----|--------|-----|---|
| 00530445 | 300 | 12 | B | 150 | 8 |
| 00530446 | 500 | 20 | B | 150 | 8 |

TWIN-CAL IP67 – Models with Two Fixed Measuring Jaws

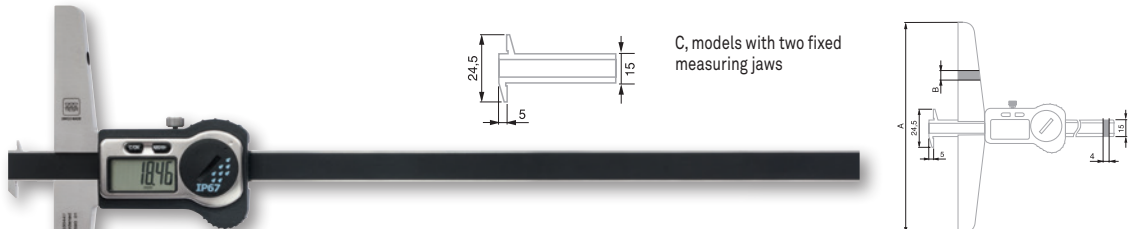

| No | | | Models | | |
|----------|-----|----|--------|-----|---|
| 00530447 | 300 | 12 | C | 150 | 8 |



TWIN-CAL IP67 – Models with Rotary Stop Plate

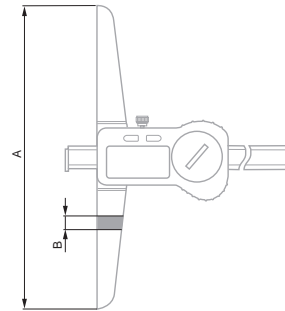
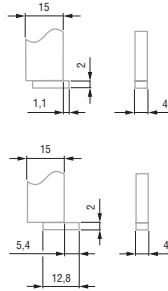
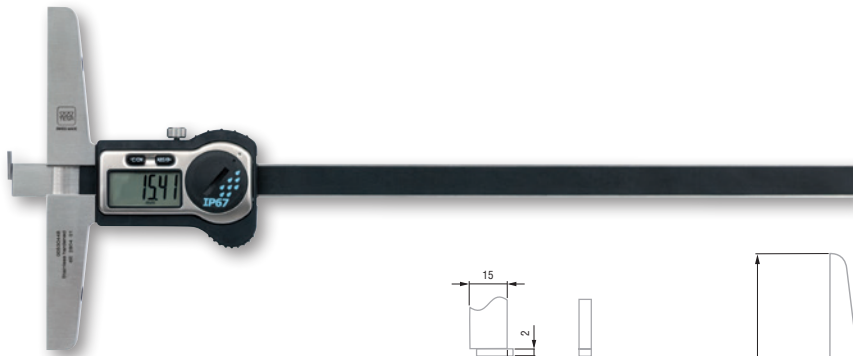

| No | mm | in | A mm | B mm |
|----------|-----|----|------|------|
| 00530448 | 250 | 10 | 100 | 8,5 |
| 00530449 | 350 | 14 | 100 | 8,5 |
| 00530450 | 500 | 20 | 150 | 8,5 |

OPTIONAL ACCESSORIES:

| | |
|----------|---|
| 01961000 | Lithium battery, 3V, CR2032 |
| 04760180 | TESA TLC-TWIN wireless emitter-receiver Compatible with any instrument fitted with a TLC – TESA Link Connector |
| 04760181 | TESA TLC-USB cable for instruments with a TLC connector |
| 04760182 | TLC-DIGIMATIC cable for instruments with a TLC connector |
| 00560103 | Removable bridge 200 mm |
| 00560104 | Removable bridge 300 mm |
| 00560105 | Removable bridge 400 mm |

TWIN-CAL IP67 – Small Sized Model with Steel Measuring Tip

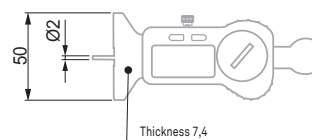

| No | mm | in |
|----------|----|----|
| 00530451 | 25 | 1 |

OPTIONAL ACCESSORIES:

| | |
|----------|---|
| 01961000 | Lithium battery, 3V, CR2032 |
| 04760180 | TESA TLC-TWIN wireless emitter-receiver Compatible with any instrument fitted with a TLC – TESA Link Connector |
| 04760181 | TESA TLC-USB cable for instruments with a TLC connector |
| 04760182 | TLC-DIGIMATIC cable for instruments with a TLC connector |

- ISO 13385-1
- 0,01 mm / 0.0005 in
- LCD, 11 mm
- Floating zero
- Metric / in conversion
- L ≤ 100 mm: 20 µm
100 < L ≤ 600 mm: 30 µm
600 < L ≤ 1000 mm: 40 µm
- 10 µm
- Scale with incremental divisions, inductive
- 2,5 m/s
- TLC Connectivity
- Stainless steel
- 3V lithium battery, CR2032
- 12.000 hours
- Standby mode after 10 minutes, instrument retains the zero position. Automatic shut off after 2 hours, instrument retains the zero in ABS mode, but the zero must be reset if the instrument is in DIFF mode.
- 10°C to 60°C
- 10°C to 40°C
- 100 %
- IP67
- 1907/2006/CE
2004/108/CE
2002/96/CE
- Plastic storage box
- Inspection report with declaration of conformity
- Serial number identification



DIN 862
(Style C-2)
NFE 11-096

Maximum
permissible errors:
in accordance with
standard

Hardened stainless
steel

Plastic storage
case

Inspection report
with a declaration
of conformity

Serial number
identification

Satin-chrome scale
background; main
scale set back
slightly for protec-
tion against wear

VERNIER DEPTH CALIPERS

Depth calipers with:

- Flat measuring face - Steel tip - Rotary stop plate - Convertible models, short cut measuring face or steel tip- Convertible models, short cut measuring face or fixed hook



TESA Vernier Calipers with a Flat Measuring Face

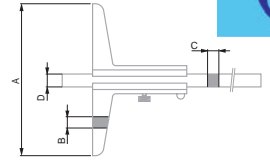

A, models with a flat measuring face

| No | mm | Models | mm | A mm | B mm | C mm | D mm |
|----------|---------|--------|------|------|------|------|------|
| 00510133 | 0 ÷ 150 | A | 0,02 | 100 | 7,5 | 3 | 8 |
| 00510134 | 0 ÷ 150 | A | 0,05 | 100 | 7,5 | 3 | 8 |
| 00510143 | 0 ÷ 250 | A | 0,02 | 100 | 7,5 | 3 | 8 |
| 00510144 | 0 ÷ 250 | A | 0,05 | 100 | 7,5 | 3 | 8 |
| 00510163 | 0 ÷ 500 | A | 0,02 | 100 | 8,5 | 4 | 12 |
| 00510164 | 0 ÷ 500 | A | 0,05 | 100 | 8,5 | 4 | 12 |
| 00510173 | 0 ÷ 600 | A | 0,02 | 150 | 8,5 | 4 | 12 |

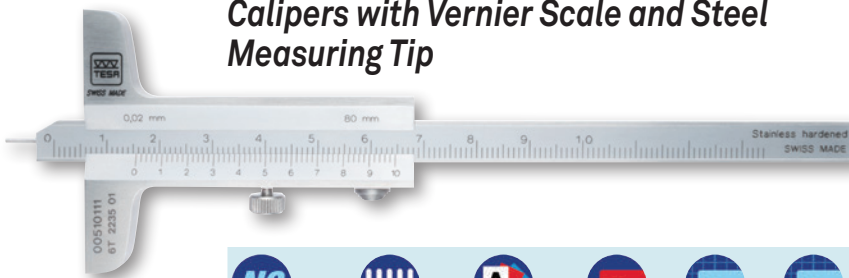

Calipers with Vernier Scale and Steel Measuring Tip

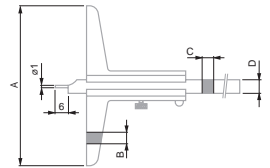

B, models with a steel measuring tip

| No | mm | Models | mm | A mm | B mm | C mm | D mm |
|----------|--------|--------|------|------|------|------|------|
| 00510111 | 0 ÷ 80 | B | 0,02 | 50 | 7,5 | 3 | 8 |

* The removable bridges available as optional accessories are not suitable for this model

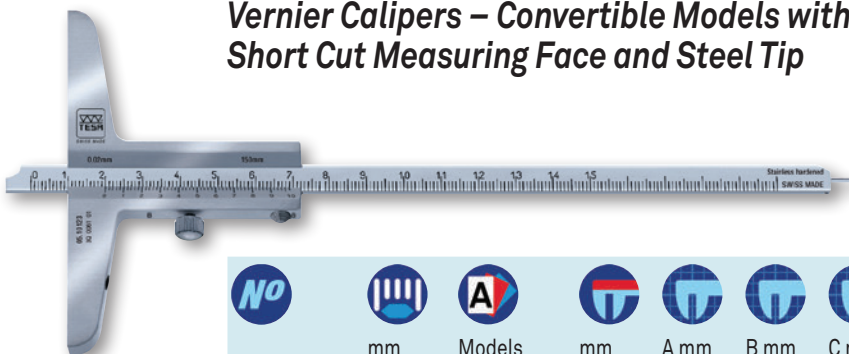

Vernier Calipers – Convertible Models with Short Cut Measuring Face and Steel Tip

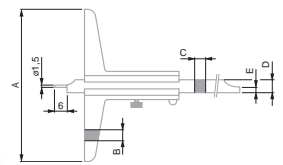

C, models with shortcut measuring face and steel tip

| No | mm | Models | mm | A mm | B mm | C mm | D mm | E mm |
|----------|---------|--------|------|------|------|------|------|------|
| 00510123 | 0 ÷ 150 | C | 0,02 | 100 | 7,5 | 3 | 8 | 3,5 |
| 00510124 | 0 ÷ 150 | C | 0,05 | 100 | 7,5 | 3 | 8 | 3,5 |
| 00510125 | 0 ÷ 250 | C | 0,02 | 100 | 7,5 | 3 | 8 | 4 |
| 00510126 | 0 ÷ 250 | C | 0,05 | 100 | 7,5 | 3 | 8 | 4 |



Vernier Calipers with Rotary Stop Plate

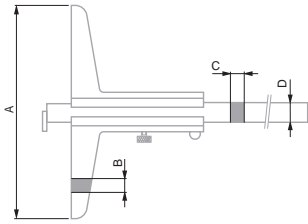
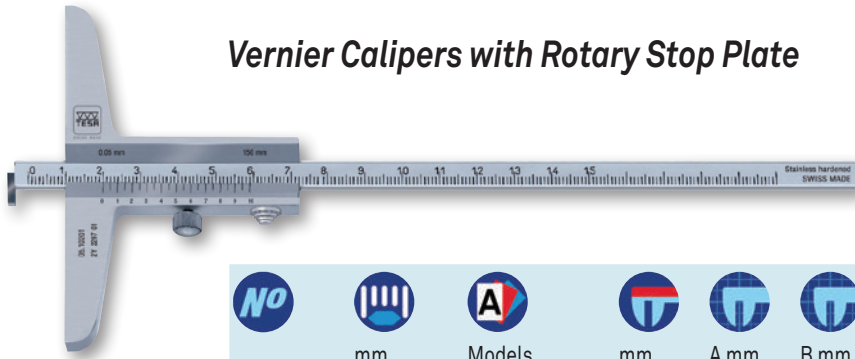

A, models with rotary stop plate

| No | mm | Models | mm | A mm | B mm | C mm | D mm |
|----------|---------|--------|------|------|------|------|------|
| 00510201 | 0 ÷ 150 | A | 0,05 | 130 | 8,5 | 4 | 12 |
| 00510202 | 0 ÷ 150 | A | 0,02 | 130 | 8,5 | 4 | 12 |
| 00510211 | 0 ÷ 250 | A | 0,05 | 130 | 8,5 | 4 | 12 |
| 00510212 | 0 ÷ 250 | A | 0,02 | 130 | 8,5 | 4 | 12 |
| 00510222 | 0 ÷ 500 | A | 0,02 | 130 | 8,5 | 4 | 12 |

OPTIONAL ACCESSORIES:

| | |
|------------|---|
| 0051610365 | Magnetic magnifying glass, 3x magnification |
| 00560103 | Removable bridge 200 mm |
| 00560104 | Removable bridge 300 mm |
| 00560105 | Removable bridge 400 mm |

Vernier Calipers – Convertible Models with Fixed Stop Plate and Short Cut Measuring Face

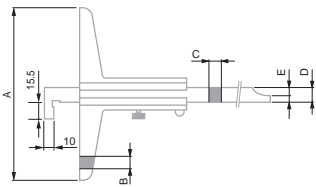

B, models with a fixed stop plate and a short cut measuring face

| No | mm | Models | mm | A mm | B mm | C mm | D mm | E mm |
|----------|---------|--------|------|------|------|------|------|------|
| 00510175 | 0 ÷ 150 | B | 0,02 | 100 | 7,5 | 3 | 8 | 3,5 |
| 00510177 | 0 ÷ 250 | B | 0,02 | 130 | 8,5 | 4 | 12 | 4 |
| 00510179 | 0 ÷ 300 | B | 0,02 | 150 | 8,5 | 4 | 12 | 4 |
| 00510181 | 0 ÷ 500 | B | 0,02 | 150 | 8,5 | 4 | 12 | 4 |

OPTIONAL ACCESSORIES:

| | |
|------------|---|
| 0051610365 | Magnetic magnifying glass, 3x magnification |
| 00560103 | Removable bridge 200 mm |
| 00560104 | Removable bridge 300 mm |
| 00560105 | Removable bridge 400 mm |

Removable Bridges



Each bridge is delivered with the appropriate fixing screws

| No | mm | µm | mm | A mm | B mm | C mm |
|----------|---------|----|------|------|------|------|
| 00560103 | ± 0,005 | 8 | 0,02 | 200 | 11,5 | 10 |
| 00560104 | ± 0,005 | 10 | 0,02 | 300 | 16 | 16 |
| 00560105 | ± 0,005 | 10 | 0,03 | 400 | 16 | 16 |



DIN 862 (Style C-2) NFE 11-096



Maximum permissible errors: in accordance with standard



Hardened stainless steel



Plastic storage case



Inspection report with a declaration of conformity



Serial number identification



Satin-chrome scale background; main scale set back slightly for protection against wear



DIN 862 (Style C-2) NFE 11-096



Maximum permissible errors, in accordance with standard



Hardened stainless steel



Plastic storage case



Inspection report with a declaration of conformity



Serial number identification



Satin-chrome scale background; main scale set back slightly for protection against wear



Factory standard



Packed suitable for shipment



Inspection report with a declaration of conformity



Serial number identification



See table

DIGITAL CALIPERS

For measurements up to 3000 mm.

INTERAPID Light

Measuring functions

- Zero setting
- Metric/Inch conversion
- Hold function for displayed value
- OPTO-RS data transfer, mono- and bi-directional
- Two adjustable points of origin (Ref I / Ref II)
- PRESET function
- MIN/MAX mode
- Two limit values for classification

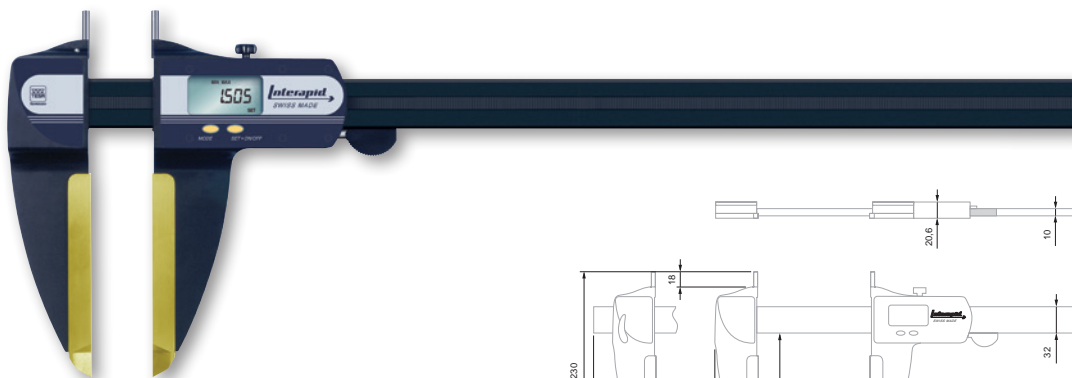

- DIN 862 and factory standard
- 0,01 mm / 0.0005 in
- LCD, 8,5 mm
- Floating zero
- mm / in conversion
- Scale with incremental divisions, inductive
- > 1,5 m/s
- Hardened steel jaws for external dimensions. Also with TiN coating, thickness to 7 mm. Tungsten carbide inserts for internal dimensions, 5 mm dia. Beam with light alloy hollow section, supported by hardened stainless steel rods.
- 3V lithium battery, CR2032
- ≈ 1,5 a (≈ 3300 h / a)
- 10°C to 60°C
- 5°C to 40°C
- IP40 (IEC 60529)
- EN 50081-1
EN 50082-1
- Packed suitable for shipping
- Inspection report for models up to 1500 mm
- Declaration of conformity
- Serial number identification
- Display lock
- RS232 Opto-coupled, mono- and bi-directional
- See table

| No | A mm | μm | μm | B Fixed | C Mobile | kg |
|----------|------|-----|----|---------|----------|-----|
| 00590061 | 330 | 30 | 20 | 618 | - | 1,1 |
| 00590062 | 630 | 40 | 20 | 918 | - | 1,3 |
| 00590063 | 1025 | 60 | 20 | - | 1306 | 1,6 |
| 00590064 | 1525 | 150 | 20 | - | 1806 | 2 |
| 00590065 | 2040 | 250 | 30 | - | 2306 | 2,3 |
| 00590066 | 2545 | 350 | 30 | - | 2806 | 2,6 |
| 00590067 | 3050 | 450 | 40 | - | 3306 | 3 |

OPTIONAL ACCESSORIES:

| | |
|----------|---|
| 01961000 | Lithium battery, 3V, CR2032 |
| 00560095 | Insert-holder, M2,5 thread |
| 00560096 | 60°conical steel pin in hardened steel |
| 00560097 | Holder for dial gauge inserts L = 28 mm |
| 00560098 | Holder for dial gauge inserts L = 58 mm |
| 00560099 | Wooden case for INTERAPID Light 300 mm |
| 00560100 | Wooden case for INTERAPID Light 600 mm |
| 00560101 | Wooden case for INTERAPID Light 1000 mm |
| 00560102 | Wooden case for INTERAPID Light 1500 mm |

Accessories for INTERAPID Light

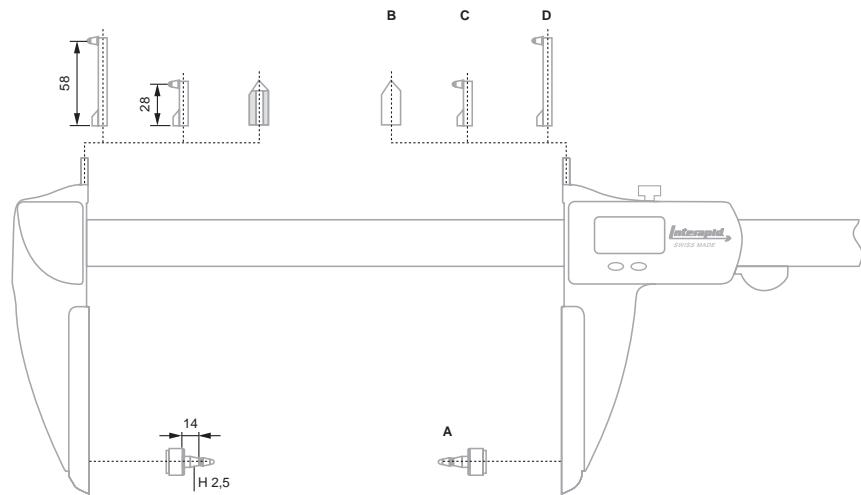

| No | A | |
|----------|---|---|
| 00560095 | Insert-holder, M2,5 thread for measuring inserts | A |
| 00560096 | 60° conical steel pin in hardened steel for measuring centre distances >10 mm | B |
| 00560097 | Holder for dial gauge inserts used for groove measurement, L = 28 mm | C |
| 00560098 | Holder for dial gauge inserts used for groove measurement, L = 58 mm | D |
| 00560099 | Wooden case for INTERAPID Light 300 mm | |
| 00560100 | Wooden case for INTERAPID Light 600 mm | |
| 00560101 | Wooden case for INTERAPID Light 1000 mm | |
| 00560102 | Wooden case for INTERAPID Light 1500 mm | |



CALIPERS WITH SPECIAL DESIGN

Calipers designated for specific measuring tasks including:

- Models with extra long jaws
- Models with hook jaws for measuring grooves
- Models for measuring throat depth

With Extra Long Jaws and Fine Adjust Device

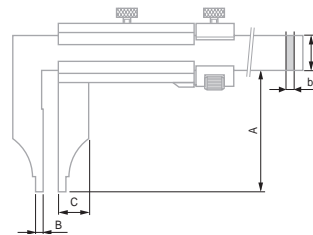
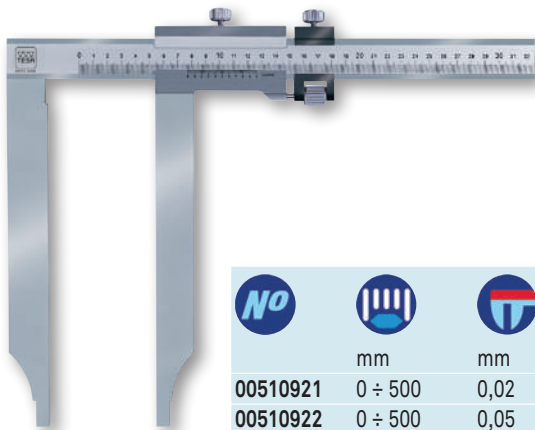

| No | mm | mm | A mm | b mm | A mm | B mm | C mm |
|----------|----------|------|------|------|------|------|------|
| 00510921 | 0 ÷ 500 | 0,02 | 28 | 6 | 250 | 10 | 30 |
| 00510922 | 0 ÷ 500 | 0,05 | 28 | 6 | 250 | 10 | 30 |
| 00510941 | 0 ÷ 1000 | 0,02 | 32 | 8 | 300 | 10 | 30 |
| 00510942 | 0 ÷ 1000 | 0,05 | 32 | 8 | 300 | 10 | 30 |

OPTIONAL ACCESSORY:

0051610365 Magnetic magnifying glass, 3x magnification

With Hook Jaws for External Dimensions

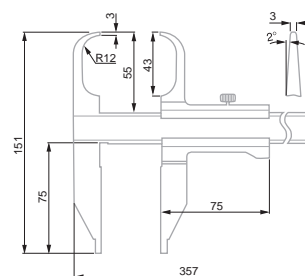
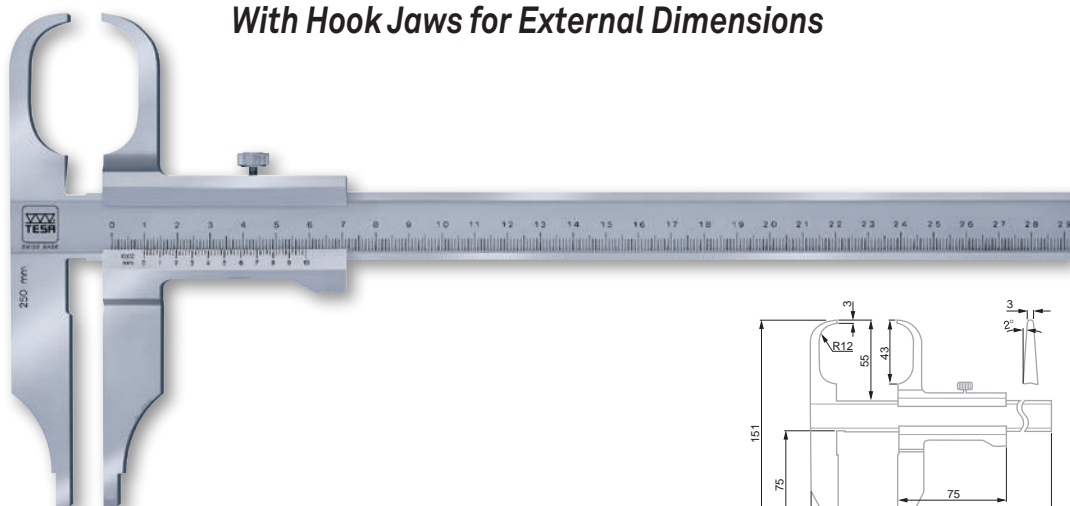

| No | mm | mm |
|----------|---------|------|
| 00510911 | 0 ÷ 250 | 0,02 |

OPTIONAL ACCESSORY:

0051610365 Magnetic magnifying glass, 3x magnification



Factory standard



Hardened stainless steel



Wooden storage case



Inspection report with a declaration of conformity



Serial number identification



Satin-chrome scale background; main scale set back slightly for protection against wear



NFE 11-096



Hardened stainless steel



Wooden storage case



Inspection report with declaration of conformity



Serial number identification



Satin-chrome scale background; main scale set back slightly for protection against wear

With Knife-edge Jaws for Internal Dimensions

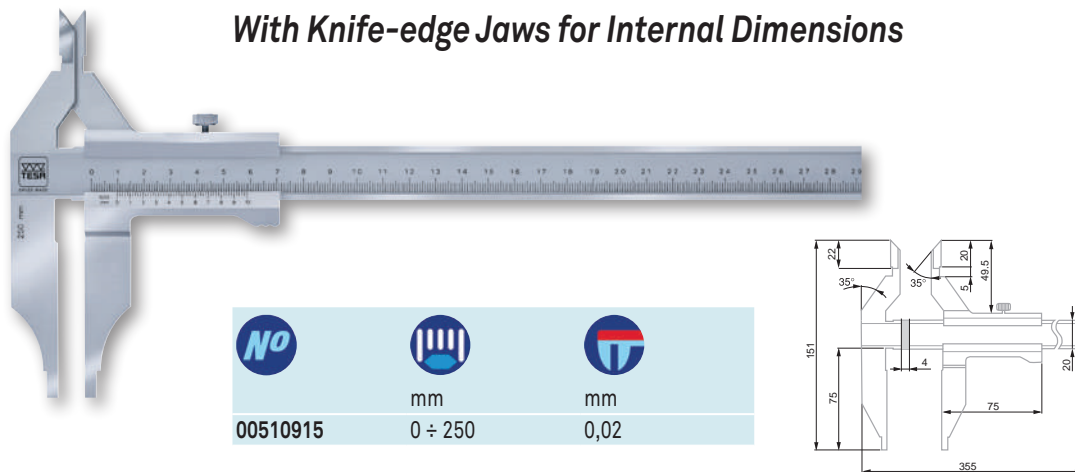

| | | |
|----------|---------|------|
| | | |
| 00510915 | 0 ÷ 250 | 0,02 |

- DIN 862 (Style DN-2) NFE 11-091
- Hardened stainless steel
- Plastic storage case
- Inspection report with a declaration of conformity
- Serial number identification
- Satin-chrome scale background; main scale set back slightly for protection against wear

With Vee Bridge

Made to measure groove and slot depths on cylindrical shafts.

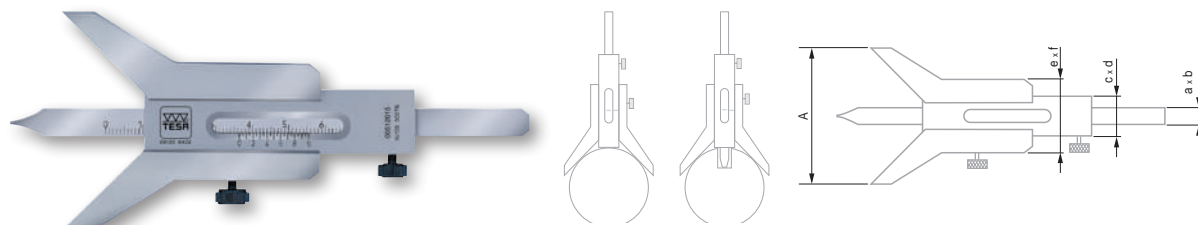

| No | | | | | | | | | |
|----------|---------|------|----|---|------|---|----|----|-----|
| 00512015 | 5 ÷ 80 | 0,05 | 8 | 2 | 18 | 5 | 32 | 10 | 60 |
| 00512016 | 6 ÷ 120 | 0,05 | 8 | 2 | 18 | 5 | 34 | 10 | 90 |
| 00512017 | 7 ÷ 160 | 0,05 | 10 | 2 | 21,5 | 5 | 42 | 10 | 120 |

- NFE 11-096
- Hardened stainless steel
- Plastic storage case
- Inspection report with a declaration of conformity
- Serial number identification
- Satin-chrome scale background; main scale set back slightly for protection against wear

For Turned Grooves

Specially designed for measuring groove or slot diameters, e.g. on safety rings.



| No | | | | | | | |
|----------|----------|------|----|---|-----|-----|-----|
| 00510371 | 10 ÷ 160 | 0,05 | 16 | 3 | 0,9 | 3 | 25 |
| 00510375 | 20 ÷ 160 | 0,05 | 16 | 3 | 2 | 5 | 40 |
| 00510383 | 26 ÷ 200 | 0,02 | 16 | 3 | 3 | 7 | 60 |
| 00510385 | 26 ÷ 200 | 0,05 | 16 | 3 | 3 | 7 | 60 |
| 00510387 | 30 ÷ 250 | 0,02 | 20 | 4 | 4 | 8,5 | 80 |
| 00510393 | 35 ÷ 300 | 0,02 | 20 | 4 | 5 | 10 | 100 |

- Factory standard
- Hardened stainless steel
- Plastic storage case
- Inspection report with a declaration of conformity
- Serial number identification
- Satin-chrome scale background; main scale set back slightly for protection against wear





External Micrometers



PRECISION MEASUREMENT





Precision measurement requires the use of micrometers. In 1848, the first measuring tool of this type was patented by the French inventor Jean Laurent Palmer as "calibre à vis et à vernier circulaire" (screw caliper with a circular vernier). Today, we continue to make external micrometers with these typical features. The introduction of the micrometer to the mechanical world came about due to the visit of the two American engineers, Joseph R. Brown and Lucian Sharpe to the Paris Exhibition in 1867. At that time, their attention was drawn to Palmer's invention, which greatly interested them. After some improvements of Palmer's design, the product was manufactured on a large scale and marketed successfully by the two partners. History repeated itself years later as TESA SA decided to manufacture external micrometers, making them the first products produced by the company.

Whether for internal or external measurement, TESA micrometers are distinguishable for their construction and quality. All our models respect the ABBE principle with the exception of the models with large measuring anvils for the measurement of gear teeth for example.



State of the art machining techniques are used for grinding the micrometer spindles, to ensure extreme accuracy and a true reproduction of the thread with negligible pitch deviations. For this reason we can guarantee a very low measuring uncertainty to our instrument users. TESA micrometers are designed to meet the most exacting demands. They are robust and ergonomically designed.

Max. permissible errors

|  |  |  |  |
|---|---|---|---|
| Measuring range mm | Maximum permissible errors* μm | Number of interference fringes or rings | μm |
| 0 ÷ 25 | 4 | 6 | 2 |
| 25 ÷ 50 | 4 | 6 | 2 |
| 50 ÷ 75 | 5 | 10 | 3 |
| 75 ÷ 100 | 5 | 10 | 3 |
| 100 ÷ 125 | 6 | | 3 |
| 125 ÷ 150 | 6 | | 3 |
| 150 ÷ 175 | 7 | | 4 |
| 175 ÷ 200 | 7 | | 4 |
| 200 ÷ 225 | 8 | | 4 |
| 225 ÷ 250 | 8 | | 4 |
| 250 ÷ 275 | 9 | | 5 |
| 275 ÷ 300 | 9 | | 5 |
| 300 ÷ 325 | 10 | | 5 |
| 325 ÷ 350 | 10 | | 5 |
| 350 ÷ 375 | 11 | | 6 |
| 375 ÷ 400 | 11 | | 6 |
| 400 ÷ 425 | 12 | | 6 |
| 425 ÷ 450 | 12 | | 6 |
| 450 ÷ 475 | 13 | | 7 |
| 475 ÷ 500 | 13 | | 7 |

* Including the errors of the measuring element as well as any deviations in the flatness and parallelism of the measuring faces, plus any errors due to the flexing of the frame.

We offer an extensive range of micrometers, from a classic model through to micrometers for special applications, and also micrometer heads, complete sets, accessories and all items needed for calibration. They are available in analogue or digital versions, and also digital versions with results output.

TESA MICROMASTER Electronic Micrometers with Digital Display

With patented TESA CAPA μ SYSTEM.

- Measuring span of 30 mm.
- Large easy-to-read digital display.
- Models:
 - EASY IP40 with a single function key.
 - IP54 with water spray protection as well as IP54 RS with an RS232 interface.



- +
- DIN 863 T1
- 0,001 mm / 0,00005 in
- LCD, digit height: 7 mm
- Floating zero
- Conversion mm/in
- Tungsten carbide tipped
- 3V lithium battery
- 1 to 2 a (\approx 2000 h/a)
- Automatic shut-down after 10 min. Display setting is maintained as long as power supply remains stable.
- -10°C to 60°C
- 10°C to 40°C
- 80 %, noncondensing
- Protection as per IEC 60529: IP40 (also valid with used RS data output) or IP54
- CE
- Plastic case
- Measuring range 0 to 100: with SCS calibration certificate
- Measuring range $>$ 100 mm : with inspection report and declaration of conformity
- Identification number
- Display lock (except for model EASY)
- RS232 interface, opto-coupled
- 0,5 mm
- Max. 10 N
- \leq 100 mm: \varnothing 6,5 mm
 $>$ 100 mm: \varnothing 8 mm

| No | | | | | | |
|----------|----------------|----------------|--------------|-------------------|------|-------|
| | mm | mm | in | in | | |
| 06030010 | 0 \div 30 | 0 \div 30 | 0 \div 1.2 | 0 \div 1.2 | IP40 | - |
| 06030020 | 0 \div 30 | 0 \div 30 | 0 \div 1.2 | 0 \div 1.2 | IP54 | - |
| 06030021 | 25 \div 50 | 23 \div 53 | 1 \div 2 | 0.9 \div 2.1 | IP54 | - |
| 06030022 | 50 \div 75 | 48 \div 78 | 2 \div 3 | 1.9 \div 3.1 | IP54 | - |
| 06030023 | 75 \div 100 | 74 \div 104 | 3 \div 4 | 2.9 \div 4.1 | IP54 | - |
| 06030030 | 0 \div 30 | 0 \div 30 | 0 \div 1.2 | 0 \div 1.2 | IP54 | RS232 |
| 06030031 | 25 \div 50 | 23 \div 53 | 1 \div 2 | 0.9 \div 2.1 | IP54 | RS232 |
| 06030032 | 50 \div 75 | 48 \div 78 | 2 \div 3 | 1.9 \div 3.1 | IP54 | RS232 |
| 06030033 | 75 \div 100 | 74 \div 104 | 3 \div 4 | 2.9 \div 4.1 | IP54 | RS232 |
| 06030071 | 100 \div 125 | 98 \div 127 | 4 \div 5 | 3.9 \div 5.01 | IP54 | RS232 |
| 06030072 | 125 \div 150 | 123 \div 152 | 5 \div 6 | 4.9 \div 6.01 | IP54 | RS232 |
| 06030073 | 150 \div 175 | 149 \div 178 | 6 \div 7 | 5.9 \div 7.01 | IP54 | RS232 |
| 06030074 | 175 \div 200 | 174 \div 203 | 7 \div 8 | 6.9 \div 8.01 | IP54 | RS232 |
| 06030075 | 200 \div 225 | 199 \div 229 | 8 \div 9 | 7.9 \div 9.01 | IP54 | RS232 |
| 06030076 | 225 \div 250 | 224 \div 254 | 9 \div 10 | 8.9 \div 10.01 | IP54 | RS232 |
| 06030077 | 250 \div 275 | 250 \div 279 | 10 \div 11 | 9.9 \div 11.01 | IP54 | RS232 |
| 06030078 | 275 \div 300 | 275 \div 304 | 11 \div 12 | 10.9 \div 12.01 | IP54 | RS232 |

OPTIONAL ACCESSORIES:

- 01961000 Lithium battery, 3V, CR2032
- 00160201 TESA micrometer stand with clamp aperture 16 mm
- 072110123 ETALON micrometer stand with clamp aperture 20 mm
- 04761062 Opto-USB cable, duplex, bidirectional communication

MICROMASTER IP54 SET

Set consisting of 3 Micromaster external micrometers covering 0 \div 75 mm measuring range.

| No | | |
|----------|---|-------------|
| 06030029 | Set of 3 MICROMASTER IP54 with RS232 output | 0 \div 75 |



CONSISTING OF:

- 06030030 MICROMASTER RS IP54 digital micrometer, 0 \div 30 mm, 0,001 mm resolution, IP54 rating and RS232 output.
- 06030031 MICROMASTER RS IP54 digital micrometer, 25 \div 50 mm, 0,001 mm resolution, IP54 rating and RS232 output.
- 06030032 MICROMASTER RS IP54 digital micrometer, 50 \div 75 mm, 0,001 mm resolution, IP54 rating and RS232 output.
- 02119021 Etalon setting standard, 50 mm



TESAMASTER High Precision Micrometers with Digital Counter Reading to 0,1 mm

Analogue indication of full millimetres, hundredths and fractions of hundredths. Accurate, parallax-free reading on the vernier down to 0,001 mm.

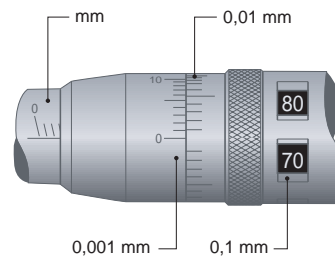

- DIN 863 T1
NFE 11-095
- Scale
division: 0,1 mm
or 0.005 in
- Tungsten carbide
- Plastic case
- Measuring range
0 to 100 mm
with inspection
report and declara-
tion of conformity
- Measuring range
> 100 mm with
a declaration of
conformity
- Identification
number
- 0,5 mm
- Max. 10 N
- ≤ 100 mm: Ø 6,5 mm
> 100 mm: Ø 8 mm
- Vernier reading
to 0,001 mm
or 0.0001 in

| No | mm | μm | μm |
|----------|-----------|----|-----|
| 00310001 | 0 ÷ 25 | 2 | 1 |
| 00310002 | 25 ÷ 50 | 2 | 1,5 |
| 00310003 | 50 ÷ 75 | 3 | 1,5 |
| 00310004 | 75 ÷ 100 | 3 | 1,5 |
| 00310005 | 100 ÷ 125 | 4 | 2 |
| 00310006 | 125 ÷ 150 | 4 | 2,5 |
| 00310007 | 150 ÷ 175 | 5 | 3 |
| 00310008 | 175 ÷ 200 | 5 | 3 |
| 00310009 | 200 ÷ 225 | 6 | 3,5 |
| 00310010 | 225 ÷ 250 | 6 | 3,5 |

- DIN 863 T1
NFE 11-095
- Tungsten carbide tipped
- Plastic case
- Inspection report with a declaration of conformity
- Identification number
- 1 mm
- Max. 10 N
- Ø 6,5 mm
- Parallax-free vernier reading to 0,001 mm

ETALON MICRORAPID 226 with 1 mm Revolution

High precision micrometers – Fast, accurate reading – No reading error of the millimetre fractions – Barrel with scale to 1 mm – Thimble with 100 graduations and vernier reading to 0,001 mm.

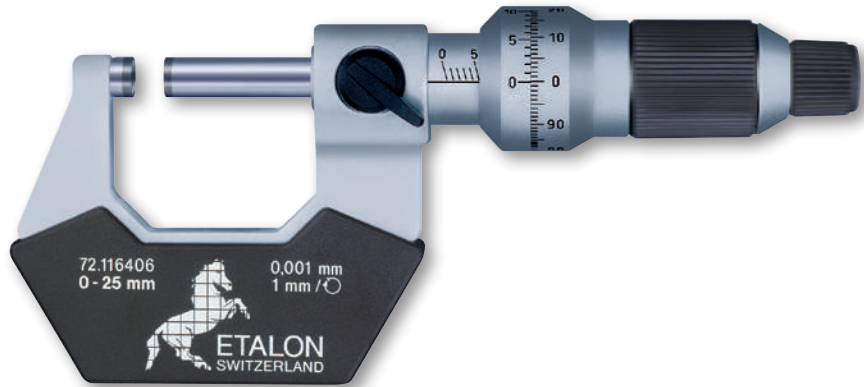

| No | | | | |
|-----------|----------|----|--|-----|
| | mm | µm | | µm |
| 072116406 | 0 ÷ 25 | 2 | | 1 |
| 072116407 | 25 ÷ 50 | 2 | | 1,5 |
| 072116408 | 50 ÷ 75 | 3 | | 1,5 |
| 072116409 | 75 ÷ 100 | 3 | | 1,5 |

- DIN 863 T1
NFE 11-095
- Tungsten carbide tipped
- Plastic case
- Measuring range 0 to 100 mm with inspection report and declaration of conformity
- Measuring range > 100 mm with a declaration of conformity
- Identification number
- 0,5 mm
- Max. 10 N
- ≤ 100 mm: Ø 6,5 mm,
> 100 ≤ 200 mm: Ø 8 mm
- 0 to 100 mm

ETALON 260 Standard Models with Analogue Indication

The knurled sleeve only needs to be reversed to render the friction drive built into the thimble inactive.



| No | | | | | |
|-----------|-----------|-------|----|--|----|
| | mm | mm | µm | | µm |
| 071115887 | 0 ÷ 25 | 0,002 | 2 | | 2 |
| 071115888 | 25 ÷ 50 | 0,002 | 2 | | 2 |
| 071115889 | 50 ÷ 75 | 0,002 | 3 | | 3 |
| 071115890 | 75 ÷ 100 | 0,002 | 3 | | 3 |
| 071115891 | 100 ÷ 125 | 0,01 | 4 | | 3 |
| 071115892 | 125 ÷ 150 | 0,01 | 4 | | 3 |
| 071115893 | 150 ÷ 175 | 0,01 | 5 | | 4 |
| 071115894 | 175 ÷ 200 | 0,01 | 5 | | 4 |



TESA ISOMASTER Standard Models with Analogue Indication

Slanted full millimetres on the barrel are set apart from the straight half millimetres to virtually eliminate reading errors.

The knurled sleeve needs only to be reversed to render the friction drive built into the thimble inactive.



| No | mm | mm |
|----------|-----------|------|
| 00110101 | 0 ÷ 25 | 0,01 |
| 00110102 | 25 ÷ 50 | 0,01 |
| 00110103 | 50 ÷ 75 | 0,01 |
| 00110104 | 75 ÷ 100 | 0,01 |
| 00110105 | 100 ÷ 125 | 0,01 |
| 00110106 | 125 ÷ 150 | 0,01 |
| 00110107 | 150 ÷ 175 | 0,01 |
| 00110108 | 175 ÷ 200 | 0,01 |
| 00110109 | 200 ÷ 225 | 0,01 |
| 00110110 | 225 ÷ 250 | 0,01 |
| 00110111 | 250 ÷ 275 | 0,01 |
| 00110112 | 275 ÷ 300 | 0,01 |

- DIN 863 T1 NFE 11-095
- Tungsten carbide tipped
- Plastic case
- Measuring range 0 to 100 mm with inspection report and declaration of conformity
- Measuring range smaller than 100 mm with a declaration of conformity
- Identification number
- 0.5 mm
- Max. 10 N
- ≤ 100 mm: Ø 6,5 mm
> 100 ≤ 300 mm: Ø 8 mm

Set of 4 TESA ISOMASTER Micrometers

The models covering application range 0 to 100 mm provide the quality that you need at competitive prices.



| No | = | mm |
|-----------------------|--|---------|
| 00110113 | Set of 4 ISOMASTER micrometers | 0 ÷ 100 |
| <i>CONSISTING OF:</i> | | |
| 00110101 | ISOMASTER AA external micrometer with vernier scale, 0 ÷ 25 mm and resolution to 0,01 mm | |
| 00110102 | ISOMASTER AA external micrometer with vernier scale, 25 ÷ 50 mm and resolution to 0,01 mm | |
| 00110103 | ISOMASTER AA external micrometer with vernier scale, 50 ÷ 75 mm and resolution to 0,01 mm | |
| 00110104 | ISOMASTER AA external micrometer with vernier scale, 75 ÷ 100 mm and resolution to 0,01 mm | |

-
- Plastic case



DIN 863 T1
NFE 11-095

Tungsten carbide
tipped

Plastic case

Inspection report
with a declaration
of conformity

No
Identification
number

0,5 mm

Max. 10 N

Ø 6,5 mm

0,01 mm

ETALON Basic to 0,01 mm

Standard micrometer with measuring range from 0 to 100 mm



| No | mm |
|----------|----------|
| 00119046 | 0 ÷ 25 |
| 00119047 | 25 ÷ 50 |
| 00119048 | 50 ÷ 75 |
| 00119049 | 75 ÷ 100 |



DIN 863 T1
NFE 11-095

Tungsten carbide
tipped

Plastic case

Inspection report
with a declaration
of conformity

No
Identification
number

0,5 mm

Max. 10 N

Ø 6,5 mm

0,01 mm

Set of 4 ETALON Basic Micrometers 0,01 mm Reading



| No | = | mm |
|-----------------------|--|---------|
| 00119050 | Set of 4 ETALON micrometers | 0 ÷ 100 |
| CONSISTING OF: | | |
| 00119046 | ETALON micrometer with measuring range 0 ÷ 25 mm | |
| 00119047 | ETALON micrometer with measuring range 25 ÷ 50 mm | |
| 00119048 | ETALON micrometer with measuring range 50 ÷ 75 mm | |
| 00119049 | ETALON micrometer with measuring range 75 ÷ 100 mm | |



MICRO-ETALON 225 - Precision Micrometers with a Dial Indicator

Feature a mobile anvil along with a built-in dial indicator. Ideal for comparative measurements on small part series. The nominal dimension is set on the micrometer while deviations are read on the dial indicator. Retractable anvil by means of a push-button. Rotating dial for fine adjustment, also with adjustable tolerance markers.

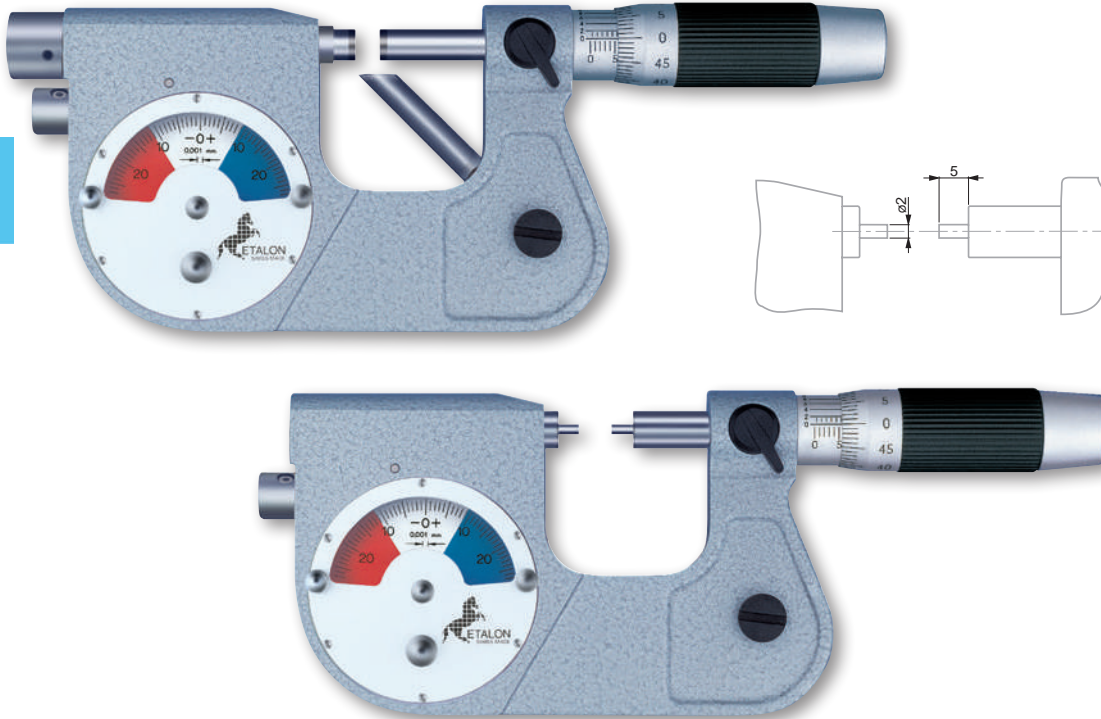

- DIN 863 T3 (Style D13)
- Micrometer: max. perm. error of 2 µm. Dial indicator: 1 µm.
- Dial indicator: repeatability limit of 0.5 µm
- Tungsten carbide tipped
- Plastic case
- Declaration of conformity
- 0,5 mm
- Anvil: 4,5 to 5,5 N
- 6,5 mm dia. Model with small measuring faces: 2 mm dia., 5 mm long
- Micrometer with vernier reading to 0,002 mm. Dial indicator: 0,001 mm.
- Dial indicator: ± 0,025 mm

| No | mm | Standard inserts |
|----------------------------|-------------------------------------|------------------|
| 072108669 | 0 ÷ 25 | Standard inserts |
| 072108691 | 25 ÷ 50 | Standard inserts |
| 072108722 | 0 ÷ 20 | Pointed inserts |
| OPTIONAL ACCESSORY: | | |
| 072110978 | Protective cover for dial indicator | |

Protective Cover for Micro-Etalon 225

Made in transparent plastic – Can be mounted on the bezel – Protects the indicator against dust particles and liquids – Prevents both tolerance markers from being accidentally displaced.



| No | |
|-----------|-------------------------------------|
| 072110978 | Protective cover for dial indicator |



DIN 863 T3
(Style D14)
NFE 11-090

Meas. element:
max. perm. error
of 2 µm

Mobile anvil:
repeatability
limit of
0,5 µm.

Tungsten carbide
tipped

Adjustable part
support (except
model with small
measuring faces).

Plastic case

Declaration
of conformity

0,5 mm

Anvil:
2 up to 8 N,
adjustable

6,5 mm or 2 mm dia.
and length of 5 mm
for models
with small
measuring faces.

Vernier reading
to 0,002 mm

ETALON MICROSPÉL 280

These micrometers have a mobile anvil along with an 8 mm diameter clamping bore for mounting a sensor with linear action such as a TESA GT 21/22 electronic probe. Specially designed for batch inspection of small precision made parts.

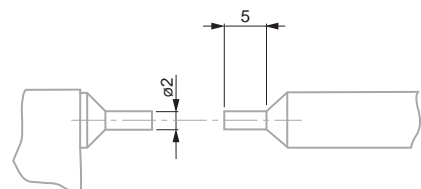
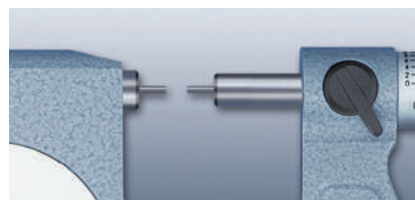

mm

072110816 0 ÷ 25 Standard inserts

072110853 0 ÷ 20 Pointed inserts

Electronic probe and micrometer stand are not part of the delivery scope and must be ordered separately.



MICROMASTER Micrometers with Small Measuring Faces

For measuring grooves, feather grooves, splines and other difficult to reach locations – Small measuring faces specially made to check small precision workpieces.



| No | mm | in |
|----------|---------|-----------|
| 06030034 | 0 ÷ 30 | 0 ÷ 1.2 |
| 06030035 | 30 ÷ 60 | 1.2 ÷ 2.3 |

OPTIONAL ACCESSORY:
01961000 Lithium battery 3V, CR2032

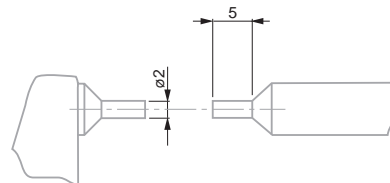

- DIN 863 T3 (Style D3)
- 0,001 mm / 0.00005 in
- Conversion mm/in
- Fixed measuring faces: tungsten carbide.
- Degree of protection (IEC 60529): IP54 or IP40 with use of the digital output
- Plastic case
- Measuring range 0 to 100: with a SCS calibration certificate.
- Identification number
- RS232 interface, opto-coupled.
- For additional technical data: see standard.
- Max. 10 N

TESAMASTER AD Micrometers with Small Measuring Faces



| No | mm |
|----------|--------|
| 00311301 | 0 ÷ 25 |

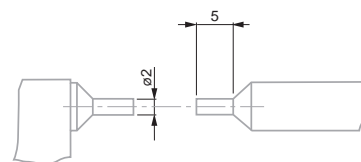

- DIN 863 T3 (Style D3) NFE 11-090
- Scale division 0,1 mm
- Fixed measuring faces: tungsten carbide
- Plastic case
- Inspection report with a declaration of conformity
- Identification number
- Max. 10 N
- Vernier reading to 0,001 mm

MICRORAPID Micrometers with Small Measuring Faces

- DIN 863 T3 (Style D3) NFE 11-090
- Fixed measuring faces: tungsten carbide
- Plastic case
- Inspection report with a declaration of conformity
- Identification number
- 1 mm
- Max. 10 N
- 0,001 mm. Parallax-free reading on vernier

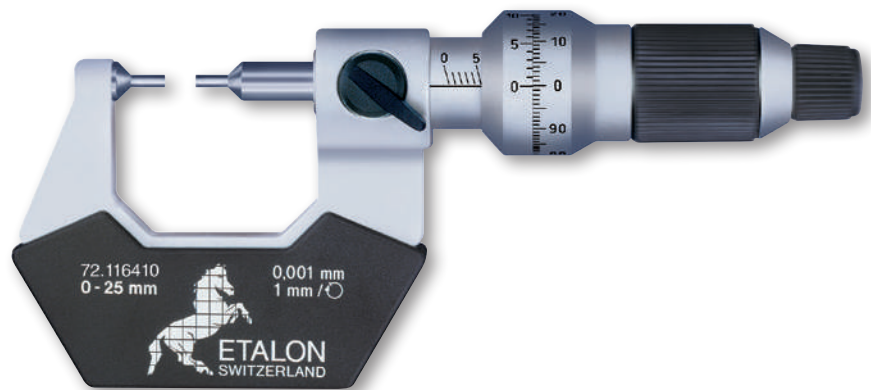

| | |
|-----------|--------------|
| | |
| 072116410 | mm 0 ÷ 20 |

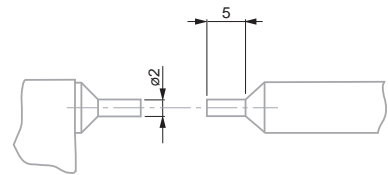

- DIN 863 T3 (Style D3) NFE 11-090
- Fixed measuring faces: tungsten carbide
- Plastic case
- Inspection report with a declaration of conformity
- Identification number
- Max. 10 N
- 0,01 mm

ISOMASTER AD Micrometers with Small Measuring Faces



| | |
|----------------------|-------------------------|
| | |
| 00210101 00210102 | mm 0 ÷ 25 25 ÷ 50 |

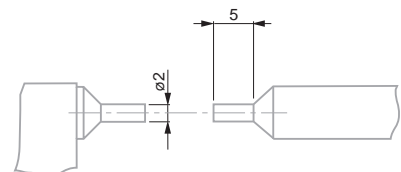

MICROMASTER Micrometers with Two Spherical Measuring Faces

Rounded measuring faces on both anvil and spindle for measuring concave surfaces on components, e.g. ball-bearing guides or wall thickness.



| No | mm | in |
|----------|----------|-----------|
| 06030081 | 0 ÷ 25 | 0 ÷ 1 |
| 06030082 | 20 ÷ 50 | 0.8 ÷ 1.9 |
| 06030083 | 45 ÷ 75 | 1.8 ÷ 2.9 |
| 06030084 | 70 ÷ 100 | 2.8 ÷ 3.9 |

MICROMASTER Micrometers with One Spherical Measuring Face

For the measurement of wall thickness of tubing and other similar tasks.



| No | mm | in |
|----------|---------|---------|
| 06030079 | 0 ÷ 30 | 0 ÷ 1.2 |
| 06030080 | 25 ÷ 50 | 1 ÷ 2 |

- DIN 863 T3 (Style D1)
- 0,001 mm / 0.00005 in
- Tungsten carbide
- Plastic case
- Inspection report with a declaration of conformity
- Identification number
- RS232
- Additional technical data: see standard.
- Max. 10 N
- Spherical: 3,5 mm radius.

- DIN 863 T3 (Style D1)
- 0,001 mm or 0.00005 in
- Anvil in tungsten carbide. Micrometric spindle in tungsten carbide
- Plastic case
- Inspection report with a declaration of conformity
- Identification number
- RS232
- Other technical data see standard.
- Max. 10 N
- Anvil with a 3,5 mm spherical face (MICROMASTER) or 3,25 mm (ETALON). Spindle with a flat measuring face.

ETALON Micrometers with One Spherical Measuring Face

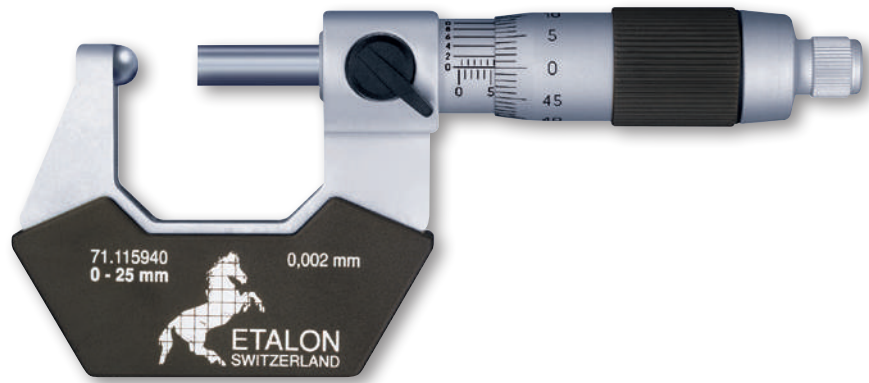

| | |
|-----------|--------|
| | |
| | mm |
| 071115940 | 0 ÷ 25 |

- DIN 863 T3 (Style D1)
- Anvil with TiC coating. Tungsten carbide spindle
- Plastic case
- Inspection report with a declaration of conformity
- Identification number
- Other technical data on MICROMASTER: see appropriate standard.
- Max. 10 N
- Anvil with 3,25 mm spherical measuring face. Spindle with a flat measuring face
- 0,002 mm



Spherical Element for External Micrometers

Holder with a ball tip to fit measuring faces \varnothing 6,5 mm – Used to measure tubing wall thickness or components with concave surfaces etc.

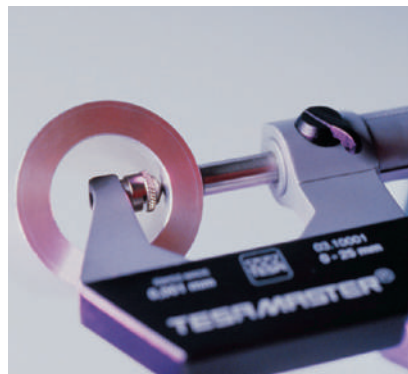

| | |
|-----------|----|
| | |
| | mm |
| 072103522 | 5 |

- Steel ball tip, hardened and lapped. Dull-chrome brass retainer



MICROMASTER Micrometers for Soft Materials

With two large, round-edge measuring faces – Measure the thickness of materials such as paper and plastic sheets, felt, cloth and other soft materials. Non-rotating measuring spindle – without spindle lock.



| | | |
|----------|--------|---------|
| No | | |
| 06030085 | 0 ÷ 30 | 0 ÷ 1.2 |

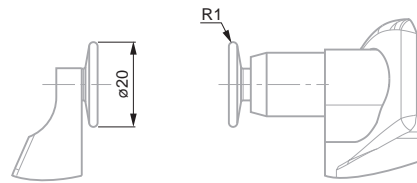

- +
- DIN 863 T3 (Style D6)
- 0,001 mm / 0.00005 in
- Conversion mm/in
- Max. permissible error: 4 µm
- Hardened steel
- Plastic case
- Inspection report with a declaration of conformity
- Identification number
- RS232
- Additional technical data: see standard.
- Max. 10 N
- Non-rotating, 20 mm diameter.
- Flatness tolerance: 3 µm
- Tolerance in Parallelism: 6 µm

ISOMASTER AF Micrometers for Soft Materials



| | |
|----------|--------|
| No | |
| 00210301 | 0 ÷ 25 |

- +
- DIN 863 T3 (Style D6)
- Hardened steel
- Plastic case
- Inspection report with a declaration of conformity
- Identification number
- Max. 10 N
- Ø 15 mm
- 0,01 mm
- Flatness tolerance: 3 µm
- Tolerance in parallelism: 6 µm

- DIN 863 T3 (Style D7)
- 0,001 mm / 0.00005 in
- Conversion mm/in
- Hardened steel
- Suitable from module 0,5 onwards
- Plastic case
- Inspection report with a declaration of conformity
- Identification number
- RS232
- Additional technical data: see standard.
- Max. 10 N
- Non-rotating spindle
≤ 85 mm: 25 mm dia.
> 85 ≤ 115 mm: 30 mm dia.

MICROMASTER Micrometers for Gear Pitch Measurement

Flanges with ring-shaped measuring faces for root tangent lengths, W_k on gear pitches, distance between grooves and slots as well as other hard-to-reach locations.

Non-rotating measuring spindle, without spindle lock.

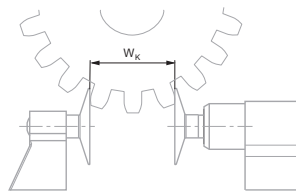

| No | mm | in |
|----------|----------|------------|
| 06030041 | 0 ÷ 30 | 0 ÷ 1.2 |
| 06030042 | 25 ÷ 55 | 1 ÷ 2.1 |
| 06030043 | 55 ÷ 85 | 2.1 ÷ 3.35 |
| 06030044 | 85 ÷ 115 | 3.35 ÷ 4.5 |

- DIN 863 T3 (Style D7) NFE 11-090
- Hardened steel
- Suitable from module 0,6
- Plastic case
- Inspection report with a declaration of conformity
- Identification number
- Max. 10 N
- ≤ 100 mm: 25 mm dia.
> 100 ≤ 150 mm: 32 mm dia.
- 0,01 mm

ISOMASTER AE Micrometers for Gear Tooth / Pitch Measurement

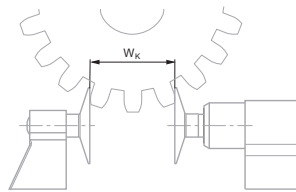

| No | mm |
|----------|-----------|
| 00210201 | 0 ÷ 25 |
| 00210202 | 25 ÷ 50 |
| 00210203 | 50 ÷ 75 |
| 00210204 | 75 ÷ 100 |
| 00210205 | 100 ÷ 125 |
| 00210206 | 125 ÷ 150 |

| Resolution | | Maximum permissible error disregarding a rim of 1 mm during inspection of the measuring faces and having partial contact with the measuring face. | | Maximum permissible error with full contact of the measuring face (DIN863-T1) | | Flatness | Parallelism | Maximum flexure of the frame |
|------------|----|---|----|---|----|----------|-------------|------------------------------|
| mm | µm | µm | µm | µm | µm | µm | µm | µm |
| 0 ÷ 30 | 10 | 4 | 4 | 2 | 5 | 2 | 5 | 2 |
| 25 ÷ 55 | 10 | 4 | 4 | 2 | 5 | 2 | 5 | 2 |
| 55 ÷ 85 | 11 | 5 | 5 | 2 | 5 | 2 | 5 | 3 |
| 85 ÷ 115 | 12 | 5 | 5 | 2 | 6 | 2 | 6 | 4 |



MICROMASTER with 7 Pairs of Interchangeable Measuring Inserts

Non-rotating spindle, without spindle lock.



| No | mm | in |
|----------------|---|---------|
| 06030045 | 0 ÷ 30 | 0 ÷ 1.2 |
| CONSISTING OF: | | |
| 06030099 | MICROMASTER single micrometer for use with interchangeable measuring inserts, 0-30 mm | |
| 00269027 | Full set of 7 pairs of inserts | |

- 0,001 mm / 0.00005 in
- Conversion mm/in
- Micrometer element with a max. perm. error of 4 µm
- Hardened steel
- 7,5 mm diameter non-rotating spindle. With a fixing bore for a measuring insert. Adjustable attachment on the anvil for a measuring insert, with lock.
- Plastic case
- Inspection report with a declaration of conformity
- Identification number
- RS232
- Additional technical data: see standard
- Max. 10 N

Full Set of Measuring Inserts for MICROMASTER with Interchangeable Inserts

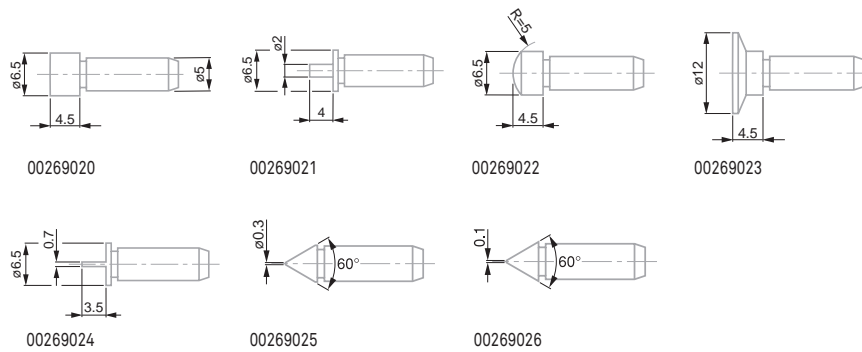

| No | = |
|--------------------------|--------------------------------|
| 00269027 | Full set of 7 pairs of inserts |
| COMPOSITION OF THE SETS: | |
| 00269020 | Pair of flat inserts |
| 00269021 | Pair of spline inserts |
| 00269022 | Pair of spherical inserts |
| 00269023 | Pair of disc inserts |
| 00269024 | Pair of blade inserts |
| 00269025 | Pair of point inserts |
| 00269026 | Pair of knife edge inserts |

- DIN 863 T3 (Style D 10)
- 0,001 mm / 0.00005 in
- Conversion mm/in
- Tungsten carbide
- Plastic case
- Inspection report with a declaration of conformity
- Identification number
- RS232
- Additional technical data: see standard.
- 0,75 mm for 3-flute test pieces or 0,559 mm for 5-flute test pieces.
- Max. 10 N
- Angle of the prism aperture: 60° for 3-flute test pieces or 108° for 5-flute test pieces.

MICROMASTER Micrometers with Prismatic Measuring Faces

Measure test pieces with an odd number of grooves such as milling cutters, taps, drills and spline shafts as well as polygons. Determine roundness errors on cylindrical surfaces. The angle of the prism aperture is designed for workpieces having 3 or 5 flutes.

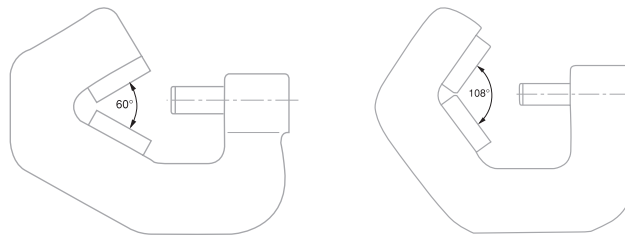

| No | mm | | A |
|----------|---------|-------------|----------------------------|
| | mm | in | |
| 06030087 | 1 ÷ 7 | 0.04 ÷ 0.27 | 3 flute test pieces (60°) |
| 06030088 | 5 ÷ 20 | 0.20 ÷ 0.80 | 3 flute test pieces (60°) |
| 06030089 | 20 ÷ 35 | 0.80 ÷ 1.38 | 3 flute test pieces (60°) |
| 06030090 | 35 ÷ 50 | 1.38 ÷ 1.97 | 3 flute test pieces (60°) |
| 06030091 | 50 ÷ 65 | 1.97 ÷ 2.56 | 3 flute test pieces (60°) |
| 06030092 | 65 ÷ 80 | 2.56 ÷ 3.15 | 3 flute test pieces (60°) |
| 06030093 | 1 ÷ 7 | 0.04 ÷ 0.27 | 5 flute test pieces (108°) |
| 06030094 | 5 ÷ 25 | 0.20 ÷ 0.98 | 5 flute test pieces (108°) |
| 06030095 | 25 ÷ 45 | 0.98 ÷ 1.77 | 5 flute test pieces (108°) |
| 06030096 | 45 ÷ 65 | 1.77 ÷ 2.56 | 5 flute test pieces (108°) |
| 06030097 | 65 ÷ 85 | 2.56 ÷ 3.35 | 5 flute test pieces (108°) |

- Alloyed steel, hardened
- With a protective cap from the nominal size of 20 mm. Effective diameter engraved on the front face.
- Declaration of conformity
- Identification number

Cylindrical Setting Standards for Micrometers

| No | μm | | Ø |
|----------|-----|-----|----|
| | μm | μm | |
| 00440001 | 0,5 | – | 5 |
| 00440002 | 0,7 | 1 | 20 |
| 00440003 | 0,7 | 1 | 25 |
| 00440004 | 1 | 1 | 35 |
| 00440005 | 1,2 | 1,5 | 45 |
| 00440006 | 1,2 | 1,5 | 50 |
| 00440007 | 1,5 | 1,5 | 65 |



MICROMASTER AC Micrometers for Thread Measurement

Used for pitch diameter inspection. Anvil with adjustable holder for mounting a measuring insert with prismatic faces. Fine screw adjustment and locking device. The spindle has a fixing bore for a cone-shaped measuring insert.



| No | mm | in |
|----------|-----------|-------|
| 06030062 | 0 ÷ 25 | 0 ÷ 1 |
| 06030063 | 25 ÷ 50 | 1 ÷ 2 |
| 06030064 | 50 ÷ 75 | 2 ÷ 3 |
| 06030065 | 75 ÷ 100 | 3 ÷ 4 |
| 06030066 | 100 ÷ 125 | 4 ÷ 5 |
| 06030067 | 125 ÷ 150 | 5 ÷ 6 |

Note: Measuring inserts and setting standards must be ordered separately.

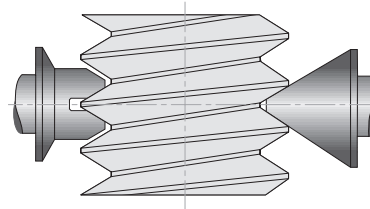

- DIN 863 T3 (Style D18)
- 0,001 mm / 0.00005 in
- Conversion mm/in
- Plastic case
- Inspection report with a declaration of conformity
- Identification number
- RS232
- Additional technical data: see appropriate standard
- Max. 10 N
- 30 mm measuring span

ISOMASTER AC Micrometers for Thread Measurement Models

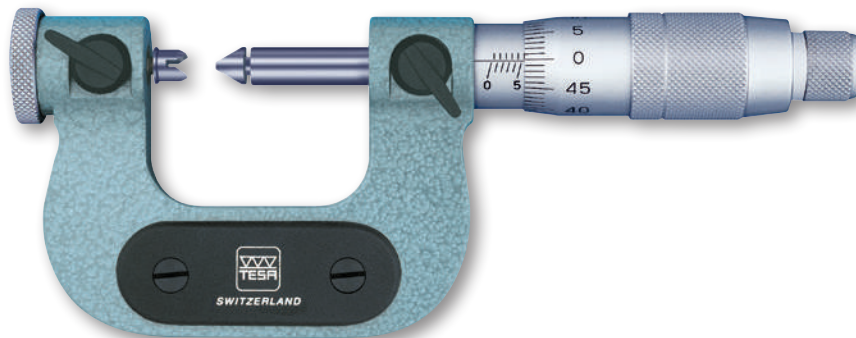

| No | mm |
|----------|----------|
| 00210001 | 0 ÷ 25 |
| 00210002 | 25 ÷ 50 |
| 00210003 | 50 ÷ 75 |
| 00210004 | 75 ÷ 100 |

Measuring inserts and setting standards must be ordered separately.

- DIN 863 T3 (Style D 18) NFE 11-090
- Plastic case
- Declaration of conformity
- Identification number
- 0,5 mm
- Max. 10 N
- 0,01 mm



Hardened steel



Supplied in sets or pairs

Fixing rod:
3,5 mm dia.,
15,5 mm long

Interchangeable Thread Inserts for TESA Micrometers Series AC

With measuring faces specially designed for checking pitch diameters.

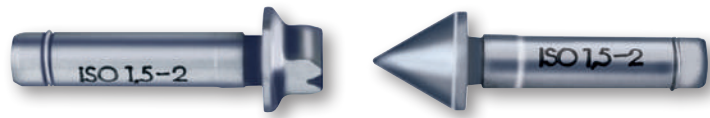

For unified inch threads, UN, UNC, UNF... 60° flank angle



00250015 Set of inserts
64 ÷ 2.5 in

COMPOSITION OF THE SETS:

00250000 AC UN,UNC,UNF
64 ÷ 42 in

00250001 AC UN,UNC,UNF
42 ÷ 25 in

00250002 AC UN,UNC,UNF
25 ÷ 17 in

00250003 AC UN,UNC,UNF
17 ÷ 10 in

00250004 AC UN,UNC,UNF
10 ÷ 6.5 in

00250005 AC UN,UNC,UNF
6.5 ÷ 4 in

00250006 AC UN,UNC,UNF
4 ÷ 2.5 in

For Whitworth threads, 55° flank angle



00250115 Set of inserts, whitworth
60 ÷ 3 in

COMPOSITION OF THE SETS:

00250100 AC whitworth 60 ÷ 48 in

00250101 AC whitworth 48 ÷ 40 in

00250102 AC whitworth 40 ÷ 32 in

00250103 AC whitworth 32 ÷ 24 in

00250104 AC whitworth 24 ÷ 18 in

00250105 AC whitworth 18 ÷ 14 in

00250106 AC whitworth 14 ÷ 10 in

00250107 AC whitworth 10 ÷ 7 in

00250108 AC whitworth 7 ÷ 4.5 in

00250109 AC whitworth 4.5 ÷ 3 in

For ISO metric threads, flank angle 60°



00240015 Set of inserts
ISO 0.40 ÷ 6.00

COMPOSITION OF THE SETS:

00240000 ISO 0.4 ÷ 0.50

00240001 ISO 0.5 ÷ 0.60

00240002 ISO 0.6 ÷ 0.80

00240003 ISO 0.8 ÷ 1.00

00240004 ISO 1.0 ÷ .25

00240005 ISO 1.25 ÷ 1.50

00240006 ISO 1.5 ÷ 2.00

00240007 ISO 2.00 ÷ 2.50

00240008 ISO 2.5 ÷ 3.00

00240009 ISO 3.00 ÷ 4.00

00240010 ISO 4.00 ÷ 5.00

00240011 ISO 5.0 ÷ 6.00



Hardened steel

Insulating sleeve
marked
with actual sizeDeclaration
of conformityIdentification
number

Setting Standards for Screw Thread Micrometers - Metric, 60° or 55° flank angle



60° flank angle, metric



Flank angle mm

| | | |
|----------|-----|-----|
| 00240501 | 60° | 25 |
| 00240502 | 60° | 50 |
| 00240503 | 60° | 75 |
| 00240504 | 60° | 100 |
| 00240505 | 60° | 125 |

60° flank angle, imperial



Flank angle in

| | | |
|----------|-----|---|
| 00250501 | 60° | 1 |
| 00250502 | 60° | 2 |
| 00250503 | 60° | 3 |
| 00250504 | 60° | 4 |
| 00250505 | 60° | 5 |

55° flank angle, metric



Flank angle mm

| | | |
|----------|-----|----|
| 00240601 | 55° | 25 |
| 00240602 | 55° | 50 |
| 00240603 | 55° | 75 |



XB Wires for Screw Threads

For measuring pitch diameter of threads using the three-wire method. Actual flank diameter d_2 can either be determined arithmetically or with the aid of the relevant tables based on the measured actual size M – Suitable for all standard micrometers with measuring faces of 6,5 mm diameter.

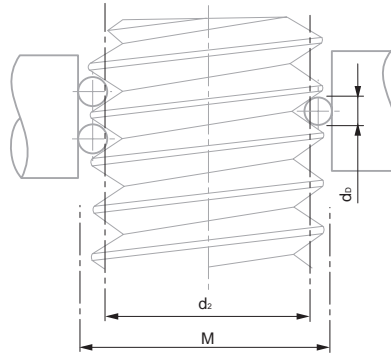
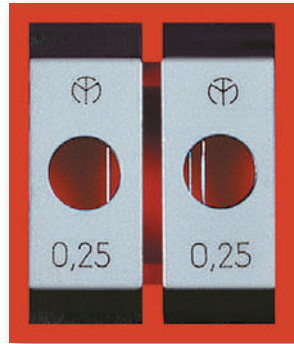

| No | \varnothing Diameter of the wires dD in mm | ISO metric threads Pitch in mm | Whitworth threads Number of threads per in | Unified inch-threads UN, UNC, UNF Number of threads per in |
|----------|---|---------------------------------------|---|---|
| 00240701 | 0,17 | 0,25 / 0,3 | – | – |
| 00240702 | 0,22 | 0,35 | – | 72 |
| 00240703 | 0,25 | 0,4 | 60 | 64 |
| 00240704 | 0,29 | 0,45 / 0,5 | – | 56 |
| 00240705 | 0,335 | 0,6 | 48 / 40 | 48 / 44 |
| 00240706 | 0,455 | 0,7 ÷ 0,8 | – | 32 |
| 00240707 | 0,53 | 0,9 | 32 / 28 | 28 |
| 00240708 | 0,62 | 1,0 | 26 / 24 | 24 |
| 00240709 | 0,725 | 1,25 | 22 ÷ 19 | 20 |
| 00240710 | 0,895 | 1,5 | 18 / 16 | 18 / 16 |
| 00240711 | 1,10 | 1,75 | 14 | 14 / 13 |
| 00240712 | 1,35 | 2,0 | 12 / 11 | 12 / 11 |
| 00240713 | 1,65 | 2,5 | 10 / 9 | 10 / 9 |
| 00240714 | 2,05 | 3,0 / 3,5 | 8 / 7 | 8 / 7 |
| 00240715 | 2,55 | 4,0 / 4,5 | 6 | 6 |
| 00240716 | 3,20 | 5,0 / 5,5 | 5 / 4,5 | 5 / 4,5 |

Set of 16 Pairs of XB Wires for Thread Measurement

| No | \varnothing Diameter of the wires dD in mm |
|----------|---|
| 00240700 | 0,17 ÷ 3,20 |



Steel wires, hardened

Single pairs are supplied in a plastic box, full set in a wooden case

Declaration of conformity

Wires are mounted on holders: 2-wire holder rests on anvil while the single wire holder is used on spindle side



Wires in hardened steel

Single pairs supplied in a plastic case, full set in a wooden box.

Declaration of conformity

Wires mounted on holders: the 2 wire holder rests on the anvil, whilst the single wire holder is used on the spindle side.

ETALON Basic for Tube Wall Thickness Measurement

Barrel-shaped anvil for measuring tube wall thickness and other curved workpieces.

- DIN 863 T3 (Style D12) NFE 11-090
- Hardened steel anvil. Tungsten carbide spindle
- Plastic case
- Inspection report with a declaration of conformity
- Identification number
- 0,5 mm
- Max. 10 N
- 5 mm Ø on anvil. 6,5 mm Ø on spindle
- 0,01 mm



| | |
|----------|--------------|
| | |
| 00219066 | mm 0 ÷ 25 |

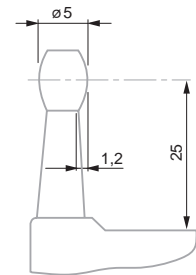

MICROMASTER with Interchangeable Anvils

All sets include 4 interchangeable anvils with increasing length in steps of 25 mm. The anvils are adjusted (and numbered) in sets, thus rendering the correction of the indication unnecessary whenever an anvil is exchanged.

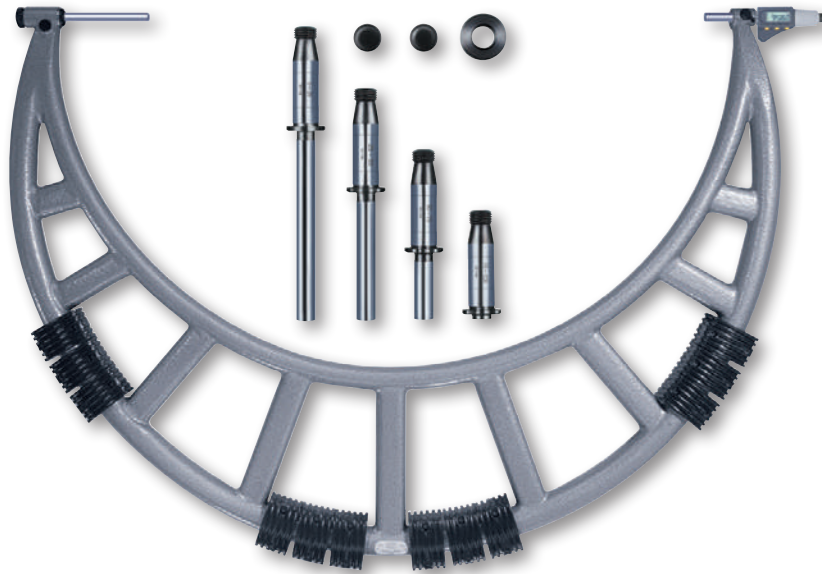

| No | | | | |
|----------|-----------|---------------|----|-----|
| | mm | in | µm | µm |
| 06030047 | 0 ÷ 100 | 0 ÷ 3.94 | 6 | 3 |
| 06030048 | 100 ÷ 200 | 3.94 ÷ 7.87 | 7 | 4,5 |
| 06030049 | 200 ÷ 300 | 7.87 ÷ 11.81 | 8 | 7 |
| 06030050 | 300 ÷ 400 | 11.81 ÷ 15.75 | 9 | 9 |
| 06030051 | 400 ÷ 500 | 15.75 ÷ 19.69 | 10 | 9 |

OPTIONAL ACCESSORIES:

| | |
|----------|---|
| 00140301 | Dial gauge element for ABY series micrometers |
| 00140101 | Interchangeable anvils AB1W |

Measuring range up to 1500 mm also available upon request.



Dial Gauge Element for MICROMASTER and AB Micrometers

Can replace the interchangeable anvils on AB series micrometers. Makes finding the culmination point easier. Ensures a constant measuring force.

| No | |
|----------|---|
| 00140301 | Dial gauge element for ABY series micrometers |

- 0,001 mm / 0,00005 in
- LCD, digit height: 7 mm
- Conversion mm/in
- Tungsten carbide tipped
- Wooden case
- Inspection report with declaration of conformity
- Identification number
- RS232
- Additional technical data: see standard
- 0,5 mm
- Max. 10 N
- Ø 8 mm
- 30 mm measuring span
- 0 ≤ 500 mm: malleable cast iron.
> 500 ≤ 1000 mm: steel tube with insulating grips. Maxium flexing of the frame under a measuring force of 10 N: see table
- Element body: Ø 11 mm, length 100 mm. Dial gauge 01410211: dial Ø 40 mm, two directional reading.
- With dial gauge and clamp
- Declaration of conformity
- Identification number
- Max. 10 N
- Ø 8 mm
- 0,01 mm
- ± 1,5 mm

- DIN 863 T3 (Style D16) NFE 11-090
- Tungsten carbide tipped
- Wooden case
- Declaration of conformity
- Identification number
- 0,5 mm
- Max. 10 N
- 8 mm diameter
- 0,01 mm
- 0 ≤ 500 mm: malleable cast iron; 500 ≤ 1000 mm: steel tube with insulating grips. Max. flexure of the frame under a measuring force of 10 N: see the table opposite

ISOMASTER AB with Interchangeable Anvils

Lightweight, but rugged anvil micrometers. Set No. 00140101 includes 4 interchangeable anvils with increasing length in steps of 25 mm.

Anvils are adjusted and numbered in pairs, thus rendering any correction of the indication unnecessary whenever an anvil is exchanged.

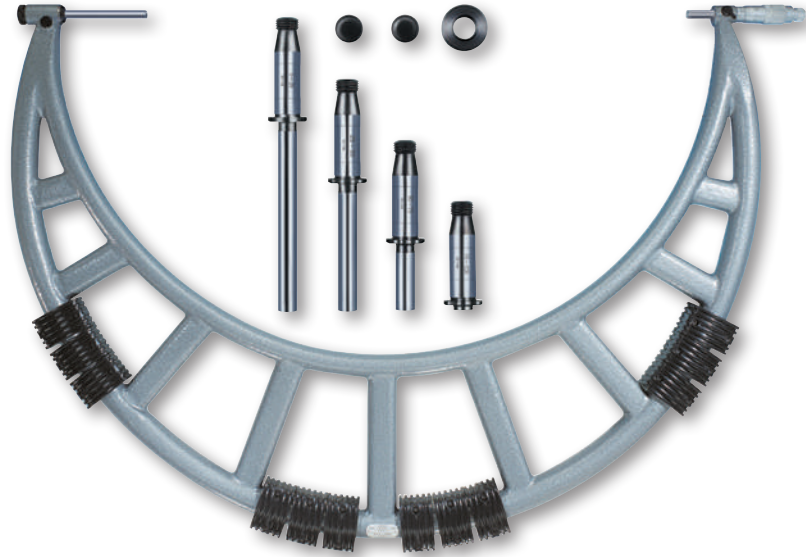

| No | mm | μm | μm |
|------------------------------|---|----|-----|
| 00111901 | 0 ÷ 100 | 6 | 3 |
| 00111902 | 100 ÷ 200 | 7 | 4,5 |
| 00111903 | 200 ÷ 300 | 8 | 7 |
| 00111904 | 300 ÷ 400 | 9 | 9 |
| 00111905 | 400 ÷ 500 | 10 | 9 |
| OPTIONAL ACCESSORIES: | | | |
| 00140101 | Interchangeable anvils AB1W | | |
| 00140301 | Dial gauge element for ABY series micrometers | | |

Measuring range up to 1500 mm also available upon request.

- DIN 863 T3 (Style D16) NFE 11-090
- Tungsten carbide tipped
- Set includes 2 guard plates for the frame as well as 1 clamping nut
- Identification number
- 8 mm diameter

Interchangeable Anvils for ISOMASTER ABY Series

Set of 4 interchangeable anvils with increasing length in steps of 25 mm. The anvils are adjusted and numbered in pairs, thus eliminating the need for resetting the indication when exchanging either of them. Supplied as standard accessories with the AB series micrometers.



| No | |
|----------|-----------------------------|
| 00140101 | Interchangeable anvils AB1W |



INTERAPID Setting Standards

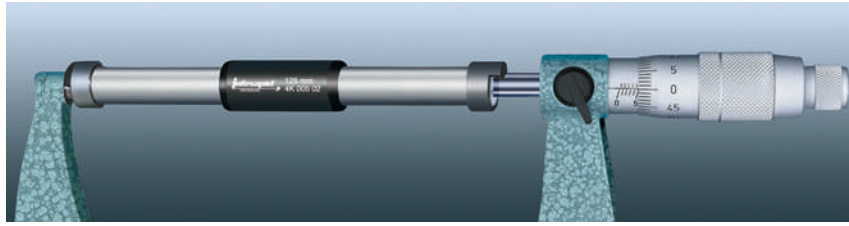

| No | mm |
|----------|-----|
| 02140001 | 25 |
| 02140002 | 50 |
| 02140003 | 75 |
| 02140004 | 100 |
| 02140005 | 125 |
| 02140006 | 150 |
| 02140007 | 175 |
| 02140008 | 200 |
| 02140009 | 225 |
| 02140010 | 250 |

| No | mm |
|----------|-----|
| 02140011 | 275 |
| 02140012 | 300 |
| 02140013 | 325 |
| 02140014 | 350 |
| 02140015 | 375 |
| 02140016 | 400 |
| 02140017 | 425 |
| 02140018 | 450 |
| 02140019 | 475 |
| 02140020 | 500 |

Measuring range up to 1500 mm also available upon request.

ETALON Cylindrical Step Gauges

For adjustment of the display and calibration.



| No | mm |
|-----------|---------|
| 072112020 | 5 ÷ 100 |
| 072112021 | 5 ÷ 150 |

Guide Collars for Setting Standards

Making the positioning of INTERAPID setting standards quick and easy.

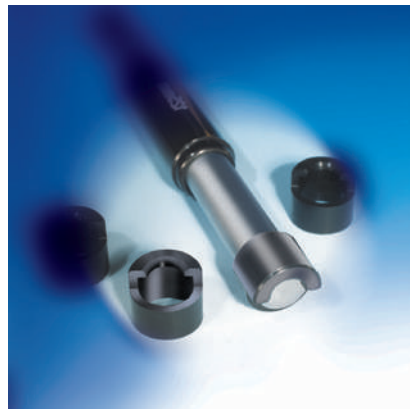

| No | mm | mm |
|----------|------------|----|
| 02140103 | 100 ÷ 175 | 8 |
| 02140108 | 200 ÷ 1475 | 8 |

- Maximum permissible error over the length: $\pm (1 + L/100) \mu\text{m}$, L in mm
- Hardened steel
- Inspection report with actual measured length
- Declaration of conformity
- Identification number
- Cylindrical gauge block with plastic insulating grip and dull chrome shaft
- Two measuring faces, flat and rounded
- With lengths: $\leq 175 \text{ mm} = 10 \text{ mm}$, $\geq 200 \text{ mm} = 13 \text{ mm}$.

-
- Maximum permissible errors for nominal diameters: $\leq 80 \text{ mm} = 1,5 \mu\text{m}$, $\geq 90 \leq 120 \text{ mm} = 2,0 \mu\text{m}$, $\geq 130 \text{ mm} = 2,5 \mu\text{m}$
- Alloyed steel, hardened
- Declaration of conformity
- Mounted on a wooden base. Supplied with dust cover.
- Diameters in steps of 5 mm ($\leq 50 \text{ mm}$) or 10 mm ($> 50 \text{ mm}$).





Angle can be locked using a single bolt.



Lacquered cast iron base



Clamp aperture: 16 mm (TESA) or 20 mm (ETALON)

Micrometer Stands

For external micrometers up to 300 mm as well as many other hand-held tools.



No

=

00160201 TESA micrometer stand with clamp aperture 16 mm

072110123 ETALON micrometer stand with clamp aperture 20 mm



Length tolerance with reference to the nominal dimension: $\pm 100 \mu\text{m}$



Each set is supplied in a wooden case



Declaration of conformity



Flatness tolerances for optical parallels with lengths:
 $\leq 27,335 \text{ mm}$
 $= 0,15 \mu\text{m}$ $\geq 52,00 \div 77,335 \text{ mm}$
 $= 0,2 \mu\text{m}$



Tolerances in parallelism for optical parallels with lengths:
 $\leq 27,335 \text{ mm}$: $0,4 \mu\text{m}$
 $\geq 52,00 \div 77,335 \text{ mm}$:
 $0,5 \mu\text{m}$



31 mm

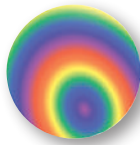
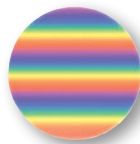

Optical Flats with Two Parallel Faces

Used for examining the flatness and parallelism of the measuring faces on external micrometers as well as other similar measuring instruments. The difference in length of the optical flats within a set matches a quarter or a third of the spindle pitch of 0,5 mm.

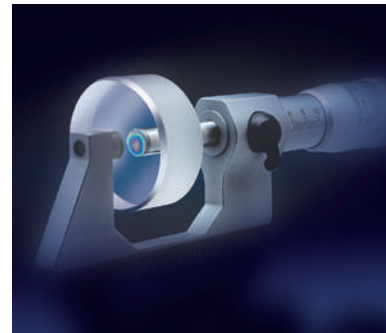

No

=

G

mm

| | | |
|----------|--|---------------------|
| 02510000 | Set interference glass 12 \div 12,375 mm | 12,00 \div 12,375 |
| 02510001 | Interference glass 12 | 12,00 |
| 02510002 | Interference glass 12,125 | 12,125 |
| 02510003 | Interference glass 12,25 mm | 12,25 |
| 02510004 | Interference glass 12,375 mm | 12,375 |
| 02510100 | Set interference glass 27 \div 27,335 mm | 27,00 \div 27,335 |
| 02510101 | Interference glass 27 mm | 27,00 |
| 02510102 | Interference glass 27,165 mm | 27,165 |
| 02510103 | Interference glass 27,335 mm | 27,335 |
| 02510200 | Set interference glass 52 - 52,3 | 52,00 \div 52,335 |
| 02510201 | Interference glass 52 mm | 52,00 |
| 02510202 | Interference glass 52,165 mm | 52,165 |
| 02510203 | Interference glass 52,335 mm | 52,335 |
| 02510300 | Set interference glass 77 \div 77,335 mm | 77,00 \div 77,335 |
| 02510301 | Interference glass 77,00 mm | 77,00 |
| 02510302 | Interference glass 77,165 mm | 77,165 |
| 02510303 | Interference glass 77,335 mm | 77,335 |



MICROMASTER Depth Micrometers

Non-rotating measuring rod. Sets with a step length of 30 mm.



| No | mm | in | mm |
|----------|---------|---------|----------|
| 06030069 | 0 ÷ 90 | 0 ÷ 3.5 | 50 x 15 |
| 06030070 | 0 ÷ 180 | 0 ÷ 7 | 100 x 15 |

Set of Depth Rods for Micromaster

Set of 6 depth rods.



| No | mm |
|----------|---------|
| 06060021 | 0 ÷ 180 |

ISOMASTER AQ Depth Micrometers

Measuring rods with a step length of 25 mm.



| No | mm | mm |
|----------|---------|----------|
| 00211002 | 0 ÷ 75 | 50 x 15 |
| 00211003 | 0 ÷ 150 | 50 x 15 |
| 00211004 | 0 ÷ 75 | 100 x 15 |
| 00211005 | 0 ÷ 150 | 100 x 15 |

- DIN 863 T2 (Style T)
 - 0,001 mm / 0.00005 in
 - Conversion mm/in
 - Max. perm. error (meas. element): 3 µm
 - Measuring rods with hardened steel tips
 - Non-rotating spindle
 - Plastic case
 - Inspection report with a declaration of conformity
 - Identification number
 - RS232 data output
 - 0,5 mm
 - 3 mm diameter measuring rods
 - 30 mm
-
- DIN 863 T2 (Style T) NFE 11-097
 - Max. perm. error of the measuring element: 3 µm
 - Measuring rods with hardened steel ends
 - Plastic case
 - Declaration of conformity
 - Identification number
 - 0,5 mm
 - 3 mm diameter measuring rods. Measuring face on the base: see table
 - 0,01 mm

- +
- DIN 863 T2 (Style E)
- 0,001 mm / 0,00005 in
- Conversion mm/in
- Max. perm. error of 4 μ m
- Tungsten carbide tipped
- Inspection report with a declaration of conformity
- RS232 interface, opto-coupled
- Additional technical data: see standard
- 0,5 mm
- Max. 10 N
- 6,5 mm dia.

MICROMETER HEADS

Micrometer heads used principally for the measurement of displacement on special fixtures such as roller tables, XY tables. Mounted using the cylindrical coupling shaft.

MICROMASTER Micrometer Heads

Without spindle lock



| No | | |
|----------|-------------|------|
| | mm | |
| 06030038 | 0 \div 30 | 12h6 |
| 06030039 | 30 \div 0 | 12h6 |
| 06030040 | 30 \div 0 | 12h6 |

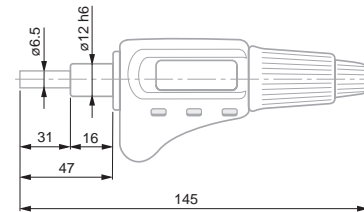

- +
- DIN 863 T2 (Style E)
- Value of the scale: 0,1 mm
- Max. perm. error of 2 μ m
- Tungsten carbide tipped
- Declaration of conformity
- Identification number
- 0,5 mm
- Max. 10 N
- 6,5 mm dia
- Vernier reading to 0,001 mm

TESAMASTER AR Micrometer Heads

Without spindle lock.



| No | | |
|----------|-------------|------|
| | mm | |
| 00312301 | 0 \div 25 | 12h6 |

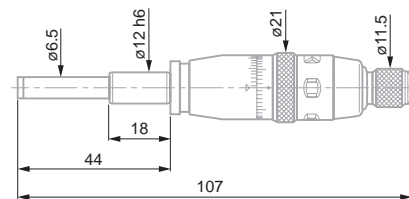

ETALON 266 Micrometer Heads

With spindle lock.

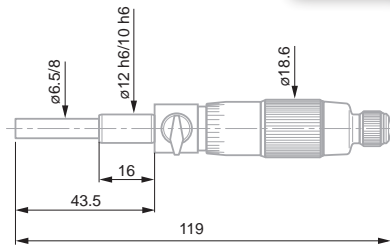

| | | | | |
|-----------|--------|-----|------|---|
| | | | | |
| 072115943 | 0 ÷ 25 | Ø 8 | 12h6 | • |

ISOMASTER AR Micrometer Heads

Without spindle lock.

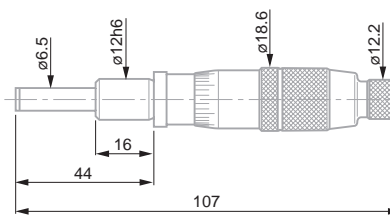

| | | |
|----------|--------|------|
| | | |
| 00211201 | 0 ÷ 25 | 12h6 |

- DIN 863 T2 (Style E) NFE 11-090
- Max. perm. error: 3 µm
- Tungsten carbide tipped
- Declaration of conformity
- Identification number
- 0,5 mm
- Vernier reading to 0,002 mm

- DIN 863 T2 (Style E) NFE 11-090
- Max. perm. error of 3 µm
- Tungsten carbide tipped
- Declaration of conformity
- Identification number
- 0,5 mm
- Max. 10 N
- 6,5 mm dia
- 0,01 mm





DIN 862

Stainless steel,
hardenedInspection report
with a declaration
of conformityTechnical data:
according to the
appropriate
standardTungsten carbide
tipped

TOOL SETS

Tool sets for the workshop, including one caliper and one micrometer.
Several digital and analogue models to choose from. Ideal tool sets for apprentices.

TESA SWISS TOOL SET



No

=

00510033 TESA SWISS TOOL SET 0-25 mm micrometer, 0-150 mm caliper

CONSISTING OF:

No

=



mm

00510041 Vernier caliper with measuring range of 150 mm and
resolution of 0,02 mm

0 ÷ 150

00560013 Depth foot for calipers up to 150 mm

00110101 ISOMASTER AA external micrometer with vernier scale,
0 ÷ 25 mm and resolution to 0,01 mm

0 ÷ 25

00560031 Case for set of instruments



TESA DUO-SET 1



- ISO 13385-1
- Stainless steel, hardened
- Inspection report with a declaration of conformity
- Technical data: see appropriate standard
- Tungsten carbide tipped

| No | = | |
|----------------|---|---|
| 00530020 | | TESA DUO-SET 1 |
| CONSISTING OF: | | |
| No | = | mm |
| 00510008 | | CCMA-M dial caliper with measuring range of 150 mm, resolution to 0,02 mm and 2 mm travel per revolution. 0 ÷ 150 |
| 00560013 | | Depth foot for calipers up to 150 mm |
| 00110101 | | ISOMASTER AA external micrometer with vernier scale, 0 ÷ 25 mm and resolution to 0,01 mm 0 ÷ 25 |
| 00560031 | | Case for set of instruments |

TESA DUO-SET 2



- DIN 862
- Stainless steel, hardened
- Inspection report with a declaration of conformity
- Technical data: according to the appropriate standard
- Tungsten carbide tipped

| No | = | |
|----------------|---|--|
| 00530021 | | TESA DUO-SET 2 |
| CONSISTING OF: | | |
| No | = | mm |
| 00510008 | | CCMA-M dial caliper with measuring range of 150 mm, resolution to 0,02 mm and 2 mm travel per revolution. 0 ÷ 150 |
| 00560013 | | Depth foot for calipers up to 150 mm |
| 00310001 | | TESAMASTER external micrometer with measuring range 0 ÷ 25 mm and vernier scale reading to resolution 0,001 mm. 0 ÷ 25 |
| 00560031 | | Case for set of instruments |



DIN 862

Stainless steel,
hardenedInspection report
with a declaration
of conformityTechnical data:
in accordance with
appropriate standardTungsten
carbide tipped

TESA DUO-SET 8



No =

00531101 TESA DUO-SET 8

CONSISTING OF:

No =



mm

00530094 Standard TWIN-CAL, electronic caliper, with measuring range 150 mm, resolution of 0,01 mm and IP40 protection rating. Round depth rod. 0 ÷ 150

00560013 Depth foot for calipers up to 150 mm

00110101 ISOMASTER AA external micrometer with vernier scale, 0 ÷ 25 mm and resolution to 0,01 mm 0 ÷ 25

00560031 Case for set of instruments



DIN 862

Stainless steel,
hardenedInspection report
with a declaration
of conformityTechnical data:
according to the
appropriate
standardTungsten
carbide tipped

TESA DUO-SET 9



No =

00531102 TESA DUO-SET 9

CONSISTING OF:

No =



mm

00530094 Standard TWIN-Cal, electronic caliper, with measuring range 150 mm, 0 ÷ 150 resolution of 0,01 mm and IP40 protection rating. Round depth rod.

00560013 Depth foot for calipers up to 150 mm

00310001 TESAMASTER external micrometer with measuring range 0 ÷ 25 mm and vernier scale reading to resolution 0,001 mm. 0 ÷ 25

00560031 Case for set of instruments



TESA DUO-SET 14



- ISO 13385-1
- Stainless steel, hardened
- SCS calibration certificate
- Technical data: see appropriate standard
- Tungsten carbide tipped

| No | = | |
|----------------|---|---------|
| 00531005 | TESA DUO-SET 14 | |
| CONSISTING OF: | | |
| No | = | |
| | | mm |
| 00530320 | TWIN-Cal electronic caliper with measuring range 150 mm, resolution 0,01 mm, IP67 rating and round depth rod. | 0 ÷ 150 |
| 00560013 | Depth foot for calipers up to 150 mm | |
| 06030010 | MICROMASTER EASY digital micrometer, 0 ÷ 30 mm, 0,001 mm resolution. | 0 ÷ 30 |
| 00560090 | Case for set of instruments | |

TESA DUO-SET 13



- ISO 13385-1
- Stainless steel, hardened.
- SCS calibration certificate
- Technical data: see appropriate standard
- Tungsten carbide tipped

| No | = | |
|----------------|--|--------|
| 00531004 | TESA DUO-SET 13 | |
| CONSISTING OF: | | |
| No | = | |
| | | mm |
| 00530319 | TWIN-Cal electronic caliper with measuring range 150 mm, resolution 0,01 mm, IP67 rating and square depth rod. | 150 |
| 00560013 | Depth foot for calipers up to 150 mm | |
| 06030020 | MICROMASTER IP54 digital micrometer, 0 ÷ 30 mm, 0,001 mm resolution, IP54 rating. | 0 ÷ 30 |
| 00560090 | Case for set of instruments | |



ISO 13385-1

Stainless steel,
hardenedSCS calibration
certificateTechnical data:
see appropriate
standardTungsten
carbide tipped

TESA DUO-SET 15



No

=

00531006 TESA DUO-SET 15

CONSISTING OF:

No

=



mm

00530321 TWIN-Cal electronic caliper with measuring range 150 mm, resolution $0 \div 150$ 0,01 mm, IP67 rating, round depth rod and thumb wheel.

00560013 Depth foot for calipers up to 150 mm

06030030 MICROMASTER RS IP54 digital micrometer, $0 \div 30$ mm, 0,001 mm resolution, IP54 rating and RS232 output.

00560090 Case for set of instruments



DIN 862

Stainless steel,
hardenedSCS calibration
certificateTechnical data:
see appropriate
standardTungsten
carbide tipped

TESA DUO-SET 16



No

=

00531007 TESA DUO-SET 16

CONSISTING OF:

No

=



mm

00530094 Standard TWIN-Cal, electronic caliper, with measuring range 150 mm, 150 resolution of 0,01 mm and IP40 protection rating. Round depth rod.

00560013 Depth foot for calipers up to 150 mm

06030010 MICROMASTER EASY digital micrometer, $0 \div 30$ mm, 0,001 mm resolution.

00560090 Case for set of instruments





Internal Measurement

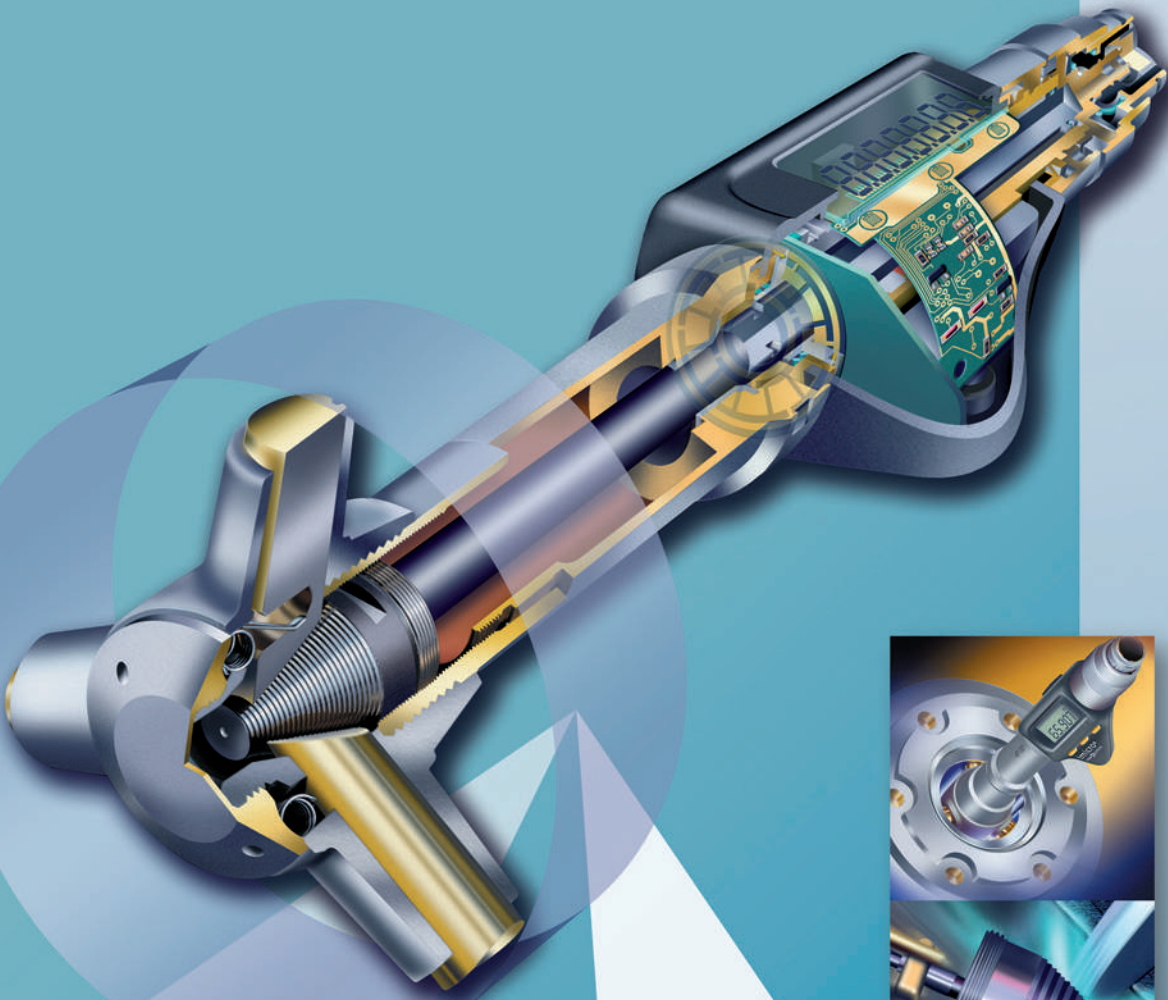

THE CHALLENGES OF INTERNAL MEASUREMENT

Bore measurement is more difficult than external measurement of components. Apart from the very tight tolerances specified, all measuring elements having a direct influence on the uncertainty of measurement must be designed in such a way that they can fit into the bore to be checked.

3-LINE CONTACT OFFERS A TRUE ADVANTAGE

The near perfect auto-centering and auto alignment provided by TESA IMICRO, TESA TRI-O-BOR, ALESOMETER and ETALON INTALOMETER make bore measurement reliable, without the need for an operator to estimate.

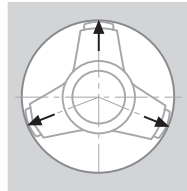

The three measuring bolts are spaced 120° apart, thus providing optimum self-centring.

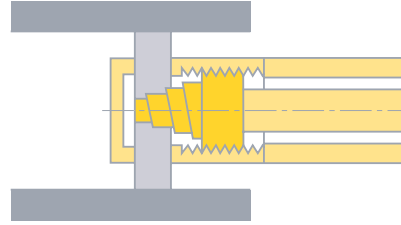

The measuring bolts with 3-line contact allows the micro-meter to align itself parallel to the contact surfaces.

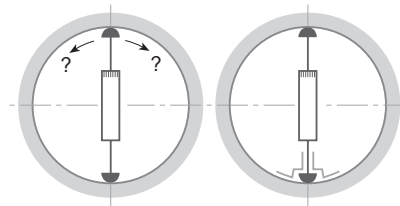

2-point contact measuring instruments are not self-centring. To enable bore measurements, the use of auxiliary means are required.

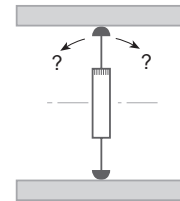

2-point contact does not permit the tool to align itself in relation to the bore axis.

A SINGLE TOOL CAN REPLACE HUNDREDS OF PLUG GAUGES

Unlike plug gauges that check only one toleranced size, a single tool can measure many diameters. Depending on the model that is being used, through holes and blind bores along with short centring shoulders can be inspected reliably.



ESTABLISHING FORM ERRORS

Form errors are established through measurements taken at several points within a bore. Micrometers with 3-line contact determine run-out errors in a triangular way. Micrometers with 2-point contact measure medium-size diameters only. They do not allow users to see what makes diameters measured at various points different.

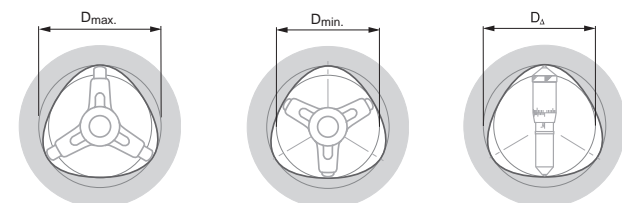
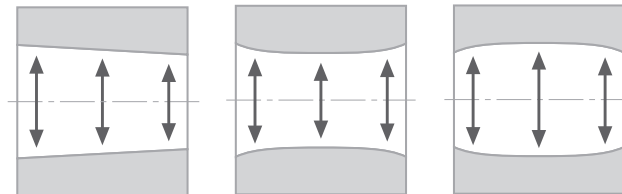

TESA IMICRO with Analogue Indication – Metric

Self-centring and self-aligning internal micrometers. The high-precision thread machined into the measuring cone, combined with the measuring bolts specially arranged to provide 3-line contact, make them the only micrometers in the world that respect the ABBE principle. Measure depth, reliably.

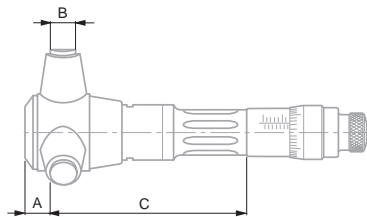
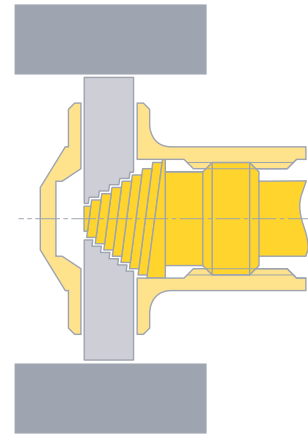
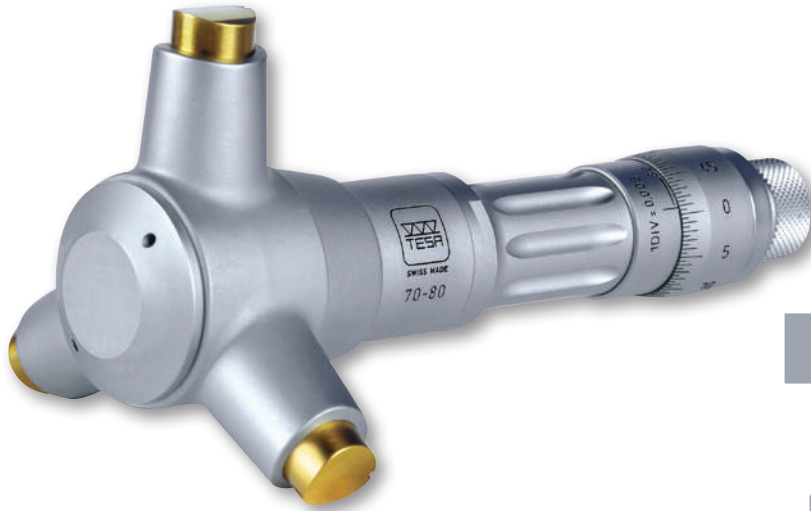

DIN 863 T4
(Style C1)
NFE 11-099



Measuring faces for application ranges from 3,5 to 12 mm:
hardened steel (HV30 770)
11 to 100 mm: TiN hard-coating (HV5 2300)
100 to 300 mm: carbide tipped (HV5 1300)



Application ranges from 3,5 to 200 mm in a shipping box
200 to 300 mm in a wooden case with 1 extension of 150 mm (No. 00842600)



Inspection report with a declaration of conformity



Identification number

| No | | | | | | | |
|----------|-----------|-------|----|----|------|------|------|
| | mm | mm | µm | µm | A mm | B mm | C mm |
| 00813410 | 3,5 ÷ 4 | 0,001 | 4 | 4 | 2 | 1,5 | 20 |
| 00813411 | 4 ÷ 4,5 | 0,001 | 4 | 4 | 2 | 1,5 | 20 |
| 00813412 | 4,5 ÷ 5,5 | 0,001 | 4 | 4 | 2 | 1,5 | 25 |
| 00813413 | 5,5 ÷ 6,5 | 0,001 | 4 | 4 | 2 | 1,5 | 25 |
| 00810001 | 6 ÷ 8 | 0,001 | 4 | 4 | 2,5 | 2,5 | 52 |
| 00810002 | 8 ÷ 10 | 0,001 | 4 | 4 | 2,5 | 2,5 | 52 |
| 00810003 | 10 ÷ 12 | 0,001 | 4 | 4 | 2,5 | 2,5 | 52 |
| 00810801 | 11 ÷ 14 | 0,005 | 4 | 4 | 3,5 | 4 | 77 |
| 00810802 | 14 ÷ 17 | 0,005 | 4 | 4 | 3,5 | 4 | 77 |
| 00810803 | 17 ÷ 20 | 0,005 | 4 | 4 | 3,5 | 4 | 77 |
| 00811501 | 20 ÷ 25 | 0,005 | 4 | 4 | 7 | 7 | 78 |
| 00811502 | 25 ÷ 30 | 0,005 | 4 | 4 | 7 | 7 | 78 |
| 00811503 | 30 ÷ 35 | 0,005 | 4 | 4 | 7 | 7 | 78 |
| 00811504 | 35 ÷ 40 | 0,005 | 4 | 4 | 7 | 7 | 78 |
| 00812301 | 40 ÷ 50 | 0,005 | 4 | 4 | 11 | 12 | 84 |
| 00812302 | 50 ÷ 60 | 0,005 | 5 | 5 | 11 | 12 | 84 |
| 00812303 | 60 ÷ 70 | 0,005 | 5 | 5 | 11 | 12 | 84 |
| 00812304 | 70 ÷ 80 | 0,005 | 5 | 5 | 11 | 12 | 84 |
| 00812305 | 80 ÷ 90 | 0,005 | 5 | 5 | 11 | 12 | 84 |
| 00812306 | 90 ÷ 100 | 0,005 | 5 | 5 | 11 | 12 | 84 |
| 00812601 | 100 ÷ 125 | 0,01 | 6 | 6 | 26 | 18 | 81 |
| 00812602 | 125 ÷ 150 | 0,01 | 6 | 6 | 26 | 18 | 81 |
| 00812603 | 150 ÷ 175 | 0,01 | 7 | 7 | 26 | 18 | 81 |
| 00812604 | 175 ÷ 200 | 0,01 | 7 | 7 | 26 | 18 | 81 |
| 00813101 | 200 ÷ 225 | 0,01 | 8 | 8 | 26 | 18 | 81 |
| 00813102 | 225 ÷ 250 | 0,01 | 8 | 8 | 26 | 18 | 81 |
| 00813103 | 250 ÷ 275 | 0,01 | 8 | 8 | 26 | 18 | 81 |
| 00813104 | 275 ÷ 300 | 0,01 | 8 | 8 | 26 | 18 | 81 |



TESA IMICRO with Analogue Indication – Full Metric Sets



DIN 863 T4
(Style C1)
NFE 11-099



Measuring faces
on models from
3,5 to 12 mm:
hardened steel,
HV30 770;
11 to 100 mm: tita-
nium nitride (TiN)
hard-coating
to HV5 2300.
100 to 200 mm:
tungsten carbide
tipped to HV5 1300.



Plastic case
or suitcase



Inspection report
with a declaration
of conformity



Identification
number



mm



Isolated
instruments



mm



Setting
rings



mm



Extensions



A mm

COMPOSITION OF THE SETS:

| | | | | | | | | |
|----------|-----|-----------|----------|-----------|----------|-----|----------|-----|
| 00813409 | BAE | 3,5 ÷ 6,5 | 00813410 | 3,5 ÷ 4 | 00843200 | 4 | | |
| | | | 00813411 | 4 ÷ 4,5 | 00843201 | 5,5 | | |
| | | | 00813412 | 4,5 ÷ 5,5 | | | | |
| | | | 00813413 | 5,5 ÷ 6,5 | | | | |
| 00810000 | BAF | 6 ÷ 12 | 00810001 | 6 ÷ 8 | 00840101 | 8 | 00840001 | 100 |
| | | | 00810002 | 8 ÷ 10 | 00840102 | 10 | | |
| | | | 00810003 | 10 ÷ 12 | | | | |
| 00810800 | BAG | 11 ÷ 20 | 00810801 | 11 ÷ 14 | 00840103 | 11 | 00840301 | 150 |
| | | | 00810802 | 14 ÷ 17 | 00840105 | 17 | | |
| | | | 00810803 | 17 ÷ 20 | | | | |
| 00811500 | BAH | 20 ÷ 40 | 00811501 | 20 ÷ 25 | 00840106 | 25 | 00841100 | 150 |
| | | | 00811502 | 25 ÷ 30 | 00840107 | 35 | | |
| | | | 00811503 | 30 ÷ 35 | | | | |
| | | | 00811504 | 35 ÷ 40 | | | | |
| 00812300 | BAJ | 40 ÷ 100 | 00812301 | 40 ÷ 50 | 00840108 | 50 | 00841800 | 150 |
| | | | 00812302 | 50 ÷ 60 | 00840109 | 70 | | |
| | | | 00812303 | 60 ÷ 70 | 00840110 | 90 | | |
| | | | 00812304 | 70 ÷ 80 | | | | |
| | | | 00812305 | 80 ÷ 90 | | | | |
| | | | 00812306 | 90 ÷ 100 | | | | |
| 00812600 | BAK | 100 ÷ 200 | 00812601 | 100 ÷ 125 | 00840112 | 125 | 00842600 | 150 |
| | | | 00812602 | 125 ÷ 150 | 00840113 | 175 | | |
| | | | 00812603 | 150 ÷ 175 | | | | |
| | | | 00812604 | 175 ÷ 200 | | | | |

TESA IMICRO CAPA μ SYSTEM with Digital Display

A successful combination of the patented TESA capacitive system with the IMICRO unique cone.

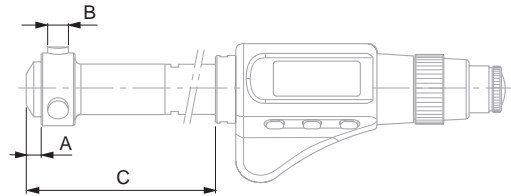

DIN 863 T4
(Style C1)

0,001 mm
0,00005 in

LCD, 7 mm
digit height

Floating zero

Metric/inch
Conversion

Measuring faces
for application
ranges 3,5 to 12 mm:
hardened steel
(770 HV 30)
11 to 100 mm:
TiN hard-coating
(2300 HV 5)
100 to 300 mm:
carbide tipped
(1300 HV 5)

3 V lithium battery

1 to 2 a
(\approx 2000 h/a)

Automatic shut
down after 10 min.
Display setting is
retained as long as
power supply
remains stable.

-10°C to 60°C

10°C to 40°C

80 %, non condensing

Measuring
element IP54
(IEC 60529) or
IP40 with active
data output



Plastic case

TESA's
calibration
certificate

Declaration
of conformity

Identification
number

Display lock

RS232
opto-coupled,
bidirectional

| No | mm | in | μ m | μ m | A mm | B mm | C mm |
|----------|-----------|-------------------|---------|---------|------|------|------|
| 06130101 | 3,5 ÷ 4 | 0.1377 ÷ 0.1574 | 4 | 4 | 2 | 1,5 | 20 |
| 06130102 | 4 ÷ 4,5 | 0.1574 ÷ 0.1771 | 4 | 4 | 2 | 1,5 | 20 |
| 06130103 | 4,5 ÷ 5,5 | 0.1771 ÷ 0.2165 | 4 | 4 | 2 | 1,5 | 25 |
| 06130104 | 5,5 ÷ 6,5 | 0.2165 ÷ 0.2559 | 4 | 4 | 2 | 1,5 | 25 |
| 06130105 | 6 ÷ 8 | 0.2362 ÷ 0.3150 | 4 | 4 | 2,5 | 2,5 | 79 |
| 06130106 | 8 ÷ 10 | 0.3150 ÷ 0.3970 | 4 | 4 | 2,5 | 2,5 | 79 |
| 06130107 | 10 ÷ 12 | 0.3970 ÷ 0.4724 | 4 | 4 | 2,5 | 2,5 | 79 |
| 06130108 | 11 ÷ 14 | 0.4330 ÷ 0.5512 | 4 | 4 | 3,5 | 4 | 93 |
| 06130109 | 14 ÷ 17 | 0.5512 ÷ 0.6693 | 4 | 4 | 3,5 | 4 | 93 |
| 06130110 | 17 ÷ 20 | 0.6693 ÷ 0.7874 | 4 | 4 | 3,5 | 4 | 93 |
| 06130111 | 20 ÷ 25 | 0.7874 ÷ 0.9843 | 4 | 4 | 7 | 7 | 91 |
| 06130112 | 25 ÷ 30 | 0.9843 ÷ 1.1811 | 4 | 4 | 7 | 7 | 91 |
| 06130113 | 30 ÷ 35 | 1.1811 ÷ 1.3780 | 4 | 4 | 7 | 7 | 91 |
| 06130114 | 35 ÷ 40 | 1.3780 ÷ 1.5748 | 4 | 4 | 7 | 7 | 91 |
| 06130115 | 40 ÷ 50 | 1.5748 ÷ 1.9685 | 4 | 4 | 11 | 12 | 104 |
| 06130116 | 50 ÷ 60 | 1.9685 ÷ 2.3622 | 5 | 5 | 11 | 12 | 104 |
| 06130117 | 60 ÷ 70 | 2.3622 ÷ 2.7560 | 5 | 5 | 11 | 12 | 104 |
| 06130118 | 70 ÷ 80 | 2.7560 ÷ 3.1496 | 5 | 5 | 11 | 12 | 104 |
| 06130119 | 80 ÷ 90 | 3.1496 ÷ 3.5433 | 5 | 5 | 11 | 12 | 104 |
| 06130120 | 90 ÷ 100 | 3.5433 ÷ 3.9370 | 5 | 5 | 11 | 12 | 104 |
| 06130121 | 100 ÷ 125 | 3.9370 ÷ 4.9212 | 6 | 6 | 26 | 18 | 100 |
| 06130122 | 125 ÷ 150 | 4.9212 ÷ 5.9055 | 6 | 6 | 26 | 18 | 100 |
| 06130123 | 150 ÷ 175 | 5.9055 ÷ 6.8897 | 7 | 7 | 26 | 18 | 100 |
| 06130124 | 175 ÷ 200 | 6.8897 ÷ 7.8740 | 7 | 7 | 26 | 18 | 100 |
| 06130125 | 200 ÷ 225 | 7.8740 ÷ 8.8582 | 8 | 8 | 26 | 18 | 100 |
| 06130126 | 225 ÷ 250 | 8.8582 ÷ 9.8425 | 8 | 8 | 26 | 18 | 100 |
| 06130127 | 250 ÷ 275 | 9.8425 ÷ 10.8267 | 8 | 8 | 26 | 18 | 100 |
| 06130128 | 275 ÷ 300 | 10.8267 ÷ 11.8110 | 8 | 8 | 26 | 18 | 100 |

OPTIONAL ACCESSORY

01961000 1 Lithium battery 3V, CR2032



TESA IMICRO CAPA μ SYSTEM with Digital Display – Full Sets

A successful combination of the TESA patented capacitive measuring system with the IMICRO unique cone.

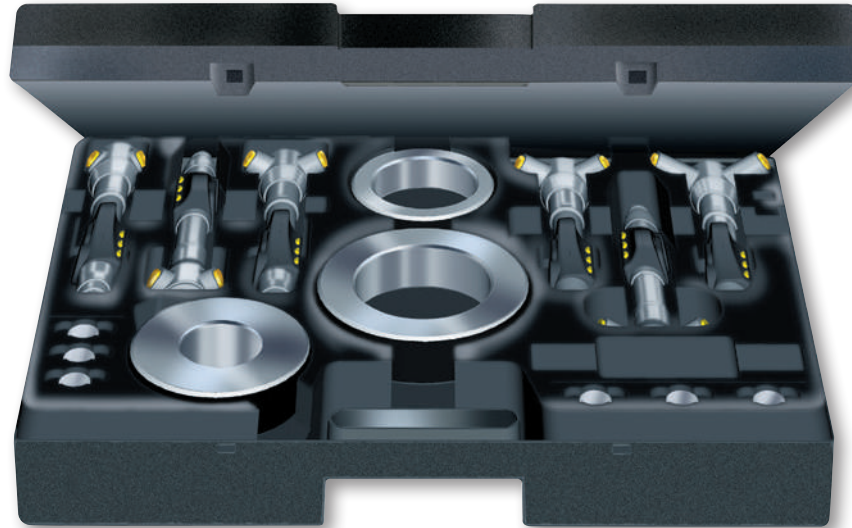

- DIN 863 T4 (Style C1)
- 0,001 mm / 0.00005 in
- LCD, 7 mm digit height
- Floating zero
- Metric/inch Conversion
- Measuring faces for application ranges 3,5 to 12 mm: hardened steel (770 HV 30)
11 to 100 mm: TIN hard-coating (2300 HV 5)
100 to 300 mm: carbide tipped (1300 HV 5)
- 3 V lithium battery
- 1 to 2 a (≈ 2000 h/a)
- Automatic shut down after 10 min. Display setting is retained as long as power supply remains stable.
- 10°C to 60°C
- 10°C to 40°C
- 80 %, non condensing
- Measuring element IP54 (IEC 60529) or IP40 with active data output
-
- Plastic case
- TESA's calibration certificate
- Declaration of conformity
- Identification number
- Display lock
- RS 232 opto-coupled, bidirectional

| | mm | Singel micrometers | mm | | Setting rings mm | | Extensions mm |
|---------------------------------|-----------|--------------------|-----------|--|------------------|-----|---------------|
| COMPOSITION OF THE SETS: | | | | | | | |
| 06130220 | 3,5 ÷ 6,5 | 06130101 | 3,5 ÷ 4 | | 00843200 | 4 | |
| | | 06130102 | 4 ÷ 4,5 | | 00843201 | 5,5 | |
| | | 06130103 | 4,5 ÷ 5,5 | | | | |
| | | 06130104 | 5,5 ÷ 6,5 | | | | |
| 06130221 | 6 ÷ 12 | 06130105 | 6 ÷ 8 | | 00840101 | 8 | 00840001 100 |
| | | 06130106 | 8 ÷ 10 | | 00840102 | 10 | |
| | | 06130107 | 10 ÷ 12 | | | | |
| 06130222 | 11 ÷ 20 | 06130108 | 11 ÷ 14 | | 00840103 | 11 | 00840301 150 |
| | | 06130109 | 14 ÷ 17 | | 00840104 | 17 | |
| | | 06130110 | 17 ÷ 20 | | | | |
| 06130223 | 20 ÷ 40 | 06130111 | 20 ÷ 25 | | 00840106 | 25 | 00841100 150 |
| | | 06130112 | 25 ÷ 30 | | 00840107 | 35 | |
| | | 06130113 | 30 ÷ 35 | | | | |
| | | 06130114 | 35 ÷ 40 | | | | |
| 06130224 | 40 ÷ 100 | 06130115 | 40 ÷ 50 | | 00840108 | 50 | 00841800 150 |
| | | 06130116 | 50 ÷ 60 | | 00840109 | 70 | |
| | | 06130117 | 60 ÷ 70 | | 00840110 | 90 | |
| | | 06130118 | 70 ÷ 80 | | | | |
| | | 06130119 | 80 ÷ 90 | | | | |
| | | 06130120 | 90 ÷ 100 | | | | |
| 06130225 | 100 ÷ 300 | 06130121 | 100 ÷ 125 | | 00840112 | 125 | 00842600 150 |
| | | 06130122 | 125 ÷ 150 | | 00840113 | 175 | |
| | | 06130123 | 150 ÷ 175 | | | | |
| | | 06130124 | 175 ÷ 200 | | | | |

TESA IMICRO CAPA μ SYSTEM with Digital Display – Partial Sets

A successful combination of the TESA patented capacitive measuring system with the IMICRO unique cone.



DIN 863 T4 (Style C1)



0,001 mm / 0.00005 in



LCD, 7 mm digit height



Floating zero



Metric/inch Conversion



Measuring faces for application ranges
3,5 to 12 mm: hardened steel (HV30 770)
11 to 100 mm: TiN hard-coating (HV5 2300)
100 to 300 mm: carbide tipped (HV5 1300)



3V lithium battery



1 to 2 a (≈ 2000 h/a)



Automatic shut down after 10 min. Display setting is retained as long as power supply remains stable.



-10°C to 60°C



10°C to 40°C



80 %, non condensing



Measuring element IP54 (IEC 60529) or IP40 with active data output



Plastic case



TESA's calibration certificate



Declaration of conformity



Identification number



Display lock



RS232 opto-coupled, bidirectional

| No | mm | No | Elements | No | Measuring heads | mm | No | Setting rings | mm | No | Extensions | mm |
|---------------------------------|-----------|----------|----------|----------|-----------------|----------|-----------|---------------|----------|-----|------------|-----|
| COMPOSITION OF THE SETS: | | | | | | | | | | | | |
| 06130230 | 3,5 ÷ 6,5 | 06130010 | 06140020 | 06140021 | 06140022 | 06140023 | 3,5 ÷ 4 | 00843200 | 00843201 | 4 | 5,5 | |
| | | | 06140024 | 06140025 | 06140026 | 06140027 | 4 ÷ 4,5 | | | | | |
| | | | 06140028 | 06140029 | 06140030 | 06140031 | 4,5 ÷ 5,5 | | | | | |
| | | | 06140032 | 06140033 | 06140034 | 06140035 | 5,5 ÷ 6,5 | | | | | |
| 06130231 | 6 ÷ 12 | 06130011 | 06140036 | 06140037 | 06140038 | 06140039 | 6 ÷ 8 | 00840101 | 00840102 | 8 | 00840001 | 100 |
| | | | 06140040 | 06140041 | 06140042 | 06140043 | 8 ÷ 10 | | | 10 | | |
| | | | 06140044 | 06140045 | 06140046 | 06140047 | 10 ÷ 12 | | | | | |
| 06130232 | 11 ÷ 20 | 06130011 | 06140048 | 06140049 | 06140050 | 06140051 | 11 ÷ 14 | 00840103 | 00840104 | 11 | 00840301 | 150 |
| | | | 06140052 | 06140053 | 06140054 | 06140055 | 14 ÷ 17 | | | 15 | | |
| | | | 06140056 | 06140057 | 06140058 | 06140059 | 17 ÷ 20 | | | | | |
| 06130233 | 20 ÷ 40 | 06130011 | 06140060 | 06140061 | 06140062 | 06140063 | 20 ÷ 25 | 00840106 | 00840107 | 25 | 00841100 | 150 |
| | | | 06140064 | 06140065 | 06140066 | 06140067 | 25 ÷ 30 | | | 35 | | |
| | | | 06140068 | 06140069 | 06140070 | 06140071 | 30 ÷ 35 | | | | | |
| | | | 06140072 | 06140073 | 06140074 | 06140075 | 35 ÷ 40 | | | | | |
| 06130234 | 40 ÷ 100 | 06130011 | 06140076 | 06140077 | 06140078 | 06140079 | 40 ÷ 50 | 00840108 | 00840109 | 50 | 00841800 | 150 |
| | | | 06140080 | 06140081 | 06140082 | 06140083 | 50 ÷ 60 | | | 70 | | |
| | | | 06140084 | 06140085 | 06140086 | 06140087 | 60 ÷ 70 | | | 90 | | |
| | | | 06140088 | 06140089 | 06140090 | 06140091 | 70 ÷ 80 | | | | | |
| | | | 06140092 | 06140093 | 06140094 | 06140095 | 80 ÷ 90 | | | | | |
| | | | 06140096 | 06140097 | 06140098 | 06140099 | 90 ÷ 100 | | | | | |
| 06130235 | 100 ÷ 300 | 06130012 | 06140100 | 06140101 | 06140102 | 06140103 | 100 ÷ 125 | 00840112 | 00840113 | 125 | 00842600 | 150 |
| | | | 06140104 | 06140105 | 06140106 | 06140107 | 125 ÷ 150 | | | 175 | | |
| | | | 06140108 | 06140109 | 06140110 | 06140111 | 150 ÷ 175 | | | | | |
| | | | 06140112 | 06140113 | 06140114 | 06140115 | 175 ÷ 200 | | | | | |

Set available on request for extending the application range from 200 to 300 mm.



Cases for Sets of IMICRO Analogue

| No | mm |
|----------|-----------|
| 00863035 | 3,5 ÷ 6,5 |
| 00863005 | 6 ÷ 12 |
| 00860008 | 11 ÷ 20 |
| 00860012 | 20 ÷ 40 |
| 00860017 | 40 ÷ 100 |
| 00863017 | 100 ÷ 200 |



Cases for Single IMICRO Digital Instruments

| No | mm |
|----------|----------|
| 06160002 | 3,5 ÷ 40 |
| 06160003 | 40 ÷ 70 |



Cases for Sets of IMICRO Digital

| No | mm |
|----------|---------------------|
| 06160005 | 6 ÷ 12 |
| 06160006 | 3,5 ÷ 6,5 / 20 ÷ 40 |
| 06160007 | 40 ÷ 100 |



Accessories for Both TESA IMICRO and TESA IMICRO CAPA μ SYSTEM – Extensions for Deep Hole Measurement

| No | mm | A mm |
|----------|-----------|------|
| 00840001 | 6 ÷ 12 | 100 |
| 00840301 | 11 ÷ 20 | 150 |
| 00840302 | 11 ÷ 20 | 500 |
| 00841100 | 20 ÷ 40 | 150 |
| 00841101 | 20 ÷ 40 | 500 |
| 00841102 | 20 ÷ 40 | 1000 |
| 00841800 | 40 ÷ 100 | 150 |
| 00841801 | 40 ÷ 100 | 500 |
| 00841802 | 40 ÷ 100 | 1000 |
| 00842600 | 100 ÷ 300 | 150 |
| 00842601 | 100 ÷ 300 | 500 |
| 00842602 | 100 ÷ 300 | 1000 |



Centring Devices for TESA IMICRO

| No | mm | A mm |
|----------|-----------|------|
| 00860001 | 40 ÷ 100 | 150 |
| 00862601 | 100 ÷ 200 | 200 |

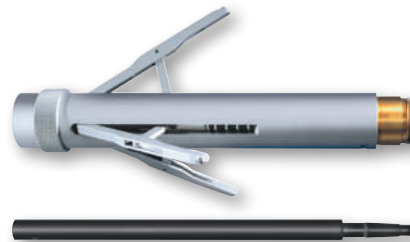

Cases for Single IMICRO Analogue Instruments

| No | mm |
|----------|-----------|
| 00860007 | 11 ÷ 20 |
| 00860011 | 20 ÷ 40 |
| 00860015 | 40 ÷ 70 |
| 00860016 | 70 ÷ 100 |
| 00863016 | 100 ÷ 300 |



DIN 863 T4
(Style C1)



ROCH ALESOMETER with Analogue Indication, Metric

Bore gauges with 3-line contact. All ROCH ALESOMETER let you measure not only through bores, but also blind bores as well as centring shoulders, except for the models covering the application range 6 to 10 mm.



NFE 11-099.
Type 1 for models
6 to 10 mm or type 2
for all other models.



Measuring inserts
for application
range 6 to 10 mm:
steel, hardened to
550 HV 30.
10 to 300 mm:
tungsten carbide
tipped to HRC ≥ 70.



Wooden case



Calibration
certificate
upon request





Declaration
of conformity

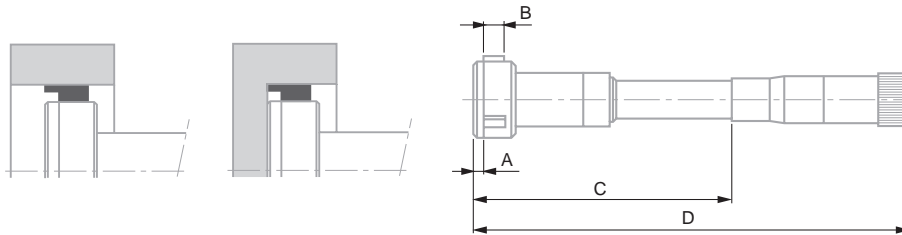

Identification
number



| No |  |  |  |  |  |  |  |
|------------|---|---|---|---|---|---|---|
| | mm | mm | µm | A mm | B mm | C mm | D mm |
| 0081725001 | 6 ÷ 8 | 0,001 | 4 | 1,2 | 3 | 54,5 | 107 |
| 0081725003 | 8 ÷ 10 | 0,001 | 4 | 1,2 | 3 | 54,5 | 107 |
| 0081725006 | 10 ÷ 12,5 | 0,001 | 4 | 0,3 | 6,5 | 64,5 | 117 |
| 0081725008 | 12,5 ÷ 15 | 0,001 | 4 | 0,3 | 6,5 | 64,5 | 117 |
| 0081725010 | 15 ÷ 17,5 | 0,001 | 4 | 0,3 | 6,8 | 64,5 | 117 |
| 0081725012 | 17,5 ÷ 20 | 0,001 | 4 | 0,3 | 6,8 | 64,5 | 117 |
| 0081725014 | 20 ÷ 25 | 0,001 | 4 | 0,3 | 8,5 | 70 | 122,5 |
| 0081725016 | 25 ÷ 30 | 0,001 | 4 | 0,3 | 8,5 | 70 | 122,5 |
| 0081725018 | 30 ÷ 35 | 0,001 | 4 | 0,3 | 8,5 | 70 | 122,5 |
| 0081725020 | 35 ÷ 40 | 0,001 | 4 | 0,3 | 8,5 | 70 | 122,5 |
| 0081725022 | 40 ÷ 50 | 0,001 | 4 | 0,3 | 14,5 | 108,7 | 188,7 |
| 0081725024 | 50 ÷ 60 | 0,001 | 5 | 0,3 | 14,5 | 108,7 | 188,7 |
| 0081725026 | 60 ÷ 70 | 0,001 | 5 | 0,3 | 14,5 | 108,7 | 188,7 |
| 0081725028 | 70 ÷ 85 | 0,001 | 5 | 0,3 | 14,5 | 126,7 | 206,7 |
| 0081725030 | 85 ÷ 100 | 0,001 | 5 | 0,3 | 14,5 | 126,7 | 206,7 |
| 0081725032 | 100 ÷ 125 | 0,01 | 7 | 0,3 | 30 | 153,7 | 233,5 |
| 0081725034 | 125 ÷ 150 | 0,01 | 7 | 0,3 | 30 | 153,7 | 233,5 |
| 0081725036 | 150 ÷ 175 | 0,01 | 8 | 0,3 | 30 | 153,7 | 233,5 |
| 0081725038 | 175 ÷ 200 | 0,01 | 8 | 0,3 | 30 | 153,7 | 233,5 |

Face A: Not applicable for models larger than 10 mm onwards, as the measuring inserts are too close to the micrometer front face.



ROCH ALESOMETER with Analogue Indication – Full Metric Sets

Bore gauges with 3-line contact. All ROCH ALESOMETER let you measure not only through bores, but also blind bores as well as centring shoulders, except for the models covering the application range 6 to 10 mm.



NFE 11-099.
Type 1 for models 6 to 10 mm or type 2 for all other models.



Bore related tolerance: $\pm (3 \mu\text{m} + 10 \cdot 10^{-6} D) \mu\text{m}$



Measuring inserts for application range 6 to 10 mm: steel, hardened to 550 HV 30.
10 to 300 mm: tungsten carbide tipped to HRC ≥ 70 .



Wooden case



Calibration certificate upon request



Declaration of conformity



Identification number



D = nominal diameter in mm ($1 \mu\text{m} + 5 \cdot 10^{-6} D) \mu\text{m}$



Extension: hardened steel, insulated body against hand warmth
Setting rings: steel, hardened to 60 HRC.



mm



Single bore gauges



mm



Setting rings



mm



Extensions



A mm

COMPOSITION OF THE SETS:

| | | | | | | | |
|------------|----------|------------|-----------|------------|------|------------|-----|
| 0081725063 | 6 ÷ 10 | 0081725001 | 6 ÷ 8 | 0211625101 | 8 | 0081625081 | 100 |
| | | 0081725003 | 8 ÷ 10 | | | | |
| 0081725066 | 10 ÷ 20 | 0081725006 | 10 ÷ 12,5 | 0211625102 | 12,5 | 0081625082 | 100 |
| | | 0081725008 | 12,5 ÷ 15 | 0211625103 | 17,5 | | |
| | | 0081725010 | 15 ÷ 17,5 | | | | |
| | | 0081725012 | 17,5 ÷ 20 | | | | |
| 0081725068 | 20 ÷ 40 | 0081725014 | 20 ÷ 25 | 0211625104 | 25 | 0081625083 | 150 |
| | | 0081725016 | 25 ÷ 30 | 0211625105 | 35 | | |
| | | 0081725018 | 30 ÷ 35 | | | | |
| | | 0081725020 | 35 ÷ 40 | | | | |
| 0081725070 | 40 ÷ 100 | 0081725022 | 40 ÷ 50 | 0211625106 | 45 | 0081625084 | 150 |
| | | 0081725024 | 50 ÷ 60 | 0211625107 | 60 | | |
| | | 0081725026 | 60 ÷ 70 | 0211625109 | 85 | | |
| | | 0081725028 | 70 ÷ 85 | | | | |
| | | 0081725030 | 85 ÷ 100 | | | | |

Extensions for Depth Increase for ROCH ALESOMETERS - Analogue Models



Hardened steel.
Insulated body against hand warmth.



Declaration of conformity



Identification number



0081625081
0081625082
0081625083
0081625084



mm

6 ÷ 10
10 ÷ 20
20 ÷ 40
40 ÷ 100



A mm

100
100
150
150

TESA ALESOMETER CAPA μ SYSTEM with Digital Display

Fitted with a TESA patented capacitive measuring system. Bore gauges with 3-line contact. All TESA ALESOMETER are made to measure through and blind bores as well as short centring shoulders, except for the models covering the application range from 6 to 10 mm.

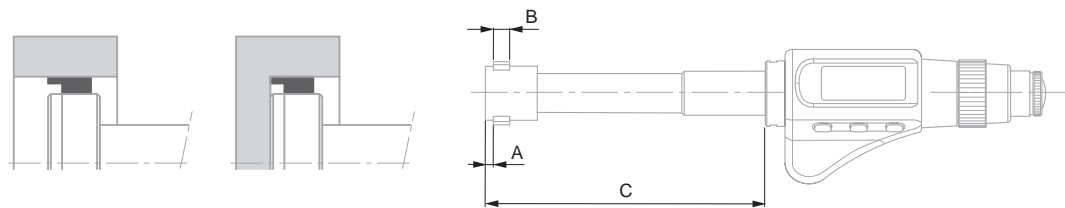

DIN 863 T4.
Style C1 for models 6 to 10 mm or style C2 for all other models.



0,001 mm /
0.00005 in



LCD, digit height
7 mm



Floating zero



Metric/inch
conversion



Measuring inserts
for application range
6 to 10 mm: steel,
hardened to
550 HV 30. 10 to 300:
tungsten carbide
tipped, HRC \geq 70.



3 V lithium battery



1 to 2 a
(\approx 2000 h/a)



Automatic shut
down after 10 min.
Display setting is
retained as long as
power supply
remains stable.



-10°C to 6°C



10°C to 40°C



80 %, non
condensing



For the measuring
element IP54
(IEC 60529) or
IP40 with active
data output



\leq 100 mm in
a plastic case
> 100 mm in
a wooden case



Inspection report
with a declaration
of conformity









Identification
number



Display lock



RS232
opto-coupled,
bidirectional

| No |  |  |  |  |  |  |  |
|----------|---|---|---|---|---|---|---|
| | mm | in | μ m | μ m | A mm | B mm | C mm |
| 06230051 | 6 \div 8 | 0.2362 \div 0.3150 | 4 | 4 | 1,2 | 3 | 55 |
| 06230052 | 8 \div 10 | 0.3150 \div 0.3970 | 4 | 4 | 1,2 | 3 | 55 |
| 06230023 | 10 \div 12,5 | 0.3970 \div 0.4921 | 4 | 4 | 0,3 | 6,5 | 65 |
| 06230024 | 12,5 \div 15 | 0.4921 \div 0.5905 | 4 | 4 | 0,3 | 6,5 | 65 |
| 06230025 | 15 \div 17,5 | 0.5905 \div 0.6890 | 4 | 4 | 0,3 | 6,8 | 65 |
| 06230026 | 17,5 \div 20 | 0.6890 \div 0.7874 | 4 | 4 | 0,3 | 6,8 | 95 |
| 06230027 | 20 \div 25 | 0.7874 \div 0.9843 | 4 | 4 | 0,3 | 8,5 | 100 |
| 06230028 | 25 \div 30 | 0.9843 \div 1.1811 | 4 | 4 | 0,3 | 8,5 | 100 |
| 06230029 | 30 \div 35 | 1.1811 \div 1.3780 | 4 | 4 | 0,3 | 8,5 | 100 |
| 06230030 | 35 \div 40 | 1.3780 \div 1.5748 | 4 | 4 | 0,3 | 8,5 | 100 |
| 06230031 | 40 \div 50 | 1.5748 \div 1.9685 | 4 | 4 | 0,3 | 14,5 | 140 |
| 06230032 | 50 \div 60 | 1.9685 \div 2.3622 | 5 | 5 | 0,3 | 14,5 | 140 |
| 06230033 | 60 \div 70 | 2.3622 \div 2.7560 | 5 | 5 | 0,3 | 14,5 | 140 |
| 06230034 | 70 \div 85 | 2.7560 \div 3.3465 | 5 | 5 | 0,3 | 14,5 | 140 |
| 06230035 | 85 \div 100 | 3.3465 \div 3.9370 | 5 | 5 | 0,3 | 14,5 | 140 |
| 06230036 | 100 \div 125 | 3.9370 \div 4.9212 | 6 | 6 | 0,3 | 30 | 175 |
| 06230037 | 125 \div 150 | 4.9212 \div 5.9055 | 6 | 6 | 0,3 | 30 | 175 |
| 06230038 | 150 \div 175 | 5.9055 \div 6.8897 | 7 | 7 | 0,3 | 30 | 175 |
| 06230039 | 175 \div 200 | 6.8897 \div 7.8740 | 7 | 7 | 0,3 | 30 | 175 |

OPTIONAL ACCESSORY

01961000 1 Lithium battery 3V, CR2032

Face A: Not applicable for models larger than 10 mm onwards, as the measuring inserts are too close to the micrometer front face.



TESA ALESOMETER CAPA μ SYSTEM with Digital Display - Partial Sets and Components

Fitted with TESA patented capacitive measuring system. Models that cover the application range from 6 to 10 mm can only measure through bores – All other partial sets also allow blind bores as well as short centring shoulders to be inspected.



DIN 863 T4.
Style C1 for models 6 to 10 mm or C2 for all other models



0,001 mm /
0.00005 in



Measuring inserts for application range 6 to 10 mm: steel, hardened to 550 HV 30. 10 to 300: tungsten carbide tipped to HRC \geq 70.



\leq 100 m in a plastic case,
 $>$ 100 m in a wooden case



Inspection report with a declaration of conformity



Identification number

| No | mm | No | Measuring heads | mm | No | Connectors | No | Measuring elements | No | Setting rings | mm | No | Storage case |
|---------------------------------|----------|------------|-----------------|------------|----------|------------|------|--------------------|------|---------------|----|----|--------------|
| COMPOSITION OF THE SETS: | | | | | | | | | | | | | |
| 06230100 | 6 ÷ 10 | 0081720351 | 6 ÷ 8 | 0081620491 | 06230020 | 0211625101 | 8 | 06260001 | | | | | |
| | | 0081720353 | | 8 ÷ 10 | | | | | | | | | |
| 06230110 | 10 ÷ 20 | 0081720356 | 10 ÷ 12,5 | 0081620492 | 06230020 | 0211625102 | 12,5 | 06260001 | | | | | |
| | | 0081720358 | | 12,5 ÷ 15 | | 0211625103 | | | 17,5 | | | | |
| | | 0081720360 | | 15 ÷ 17,5 | | | | | | | | | |
| | | 0081720362 | | 17,5 ÷ 20 | | | | | | | | | |
| 06230111 | 20 ÷ 40 | 0081720364 | 20 ÷ 25 | 0081620493 | 06230020 | 0211625104 | 25 | 06260001 | | | | | |
| | | 0081720366 | | 25 ÷ 30 | | 0211625105 | | | 35 | | | | |
| | | 0081720368 | | 30 ÷ 35 | | | | | | | | | |
| | | 0081720370 | | 35 ÷ 40 | | | | | | | | | |
| 06230112 | 40 ÷ 100 | 0081720372 | 40 ÷ 50 | 0081620494 | 06230020 | 0211625106 | 45 | 0081629525 | | | | | |
| | | 0081720374 | | 50 ÷ 60 | | 0211625107 | | | 60 | | | | |
| | | 0081720376 | | 60 ÷ 70 | | 0211625109 | | | 85 | | | | |
| | | 0081720378 | | 70 ÷ 85 | | | | | | | | | |
| | | 0081720380 | | 85 ÷ 100 | | | | | | | | | |

Set available on request for extending the application range from 100 to 300 mm.



Models from
10 to 100 mm:
DIN 863 T4
(Style C2)
NFE 11-099



Max. perm. error
for models covering
the application
ranges from
5 to 40 mm = 3 μ m
40 to 100 mm = 4 μ m
100 to 200 mm = 5 μ m



Repeatability
limit for models
covering the appli-
cation ranges from
5 to 40 mm = 3 μ m
40 to 100 mm = 4 μ m
100 to 200 mm = 5 μ m



Measuring bolts
on models from
5 to 100 mm:
hardened steel.
100 to 200 mm:
tungsten carbide
tipped



Protective case
or carrying case



Inspection report
with a declaration
of conformity



Identification
number









Models from
5 to 100 mm:
0,002 mm
Models 100 to
200 mm with vernier
reading: 0,01 mm

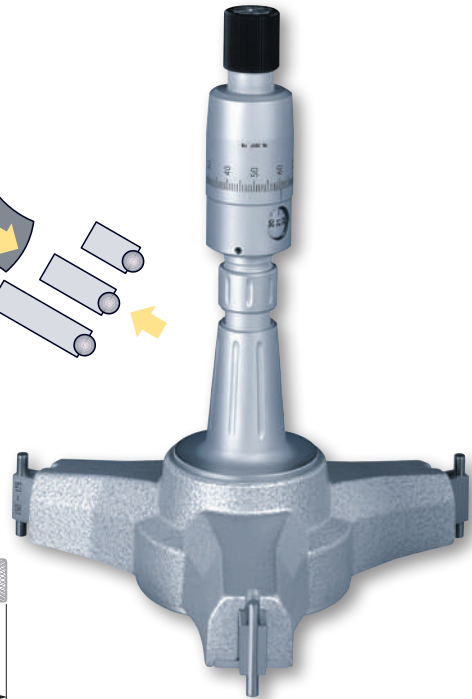
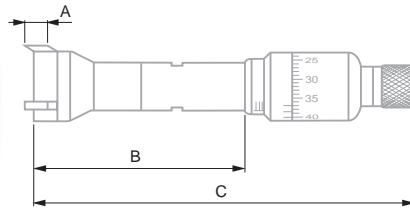
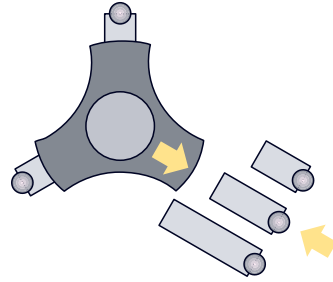

ETALON INTALOMETER 531

Made to check through holes, blind bores and short centring shoulders. All models covering the application range up to 100 mm have sloped bolts extending beyond the front face of the measuring head.



| No |  |  |  |  |  |
|-----------|---|---|---|---|---|
| | mm | | A mm | B mm | C mm |
| 078112356 | 5 ÷ 6 | 2 x 180° | 3 | ≥ 32 | ≤ 109 |
| 078112357 | 6 ÷ 7 | 2 x 180° | 3 | ≥ 33 | ≤ 111 |
| 078112358 | 7 ÷ 8,5 | 2 x 180° | 4 | ≥ 60 | ≤ 130 |
| 078112359 | 8,5 ÷ 10 | 2 x 180° | 4 | ≥ 72 | ≤ 133 |
| 078112360 | 10 ÷ 12,5 | 3 x 120° | 3 | ≥ 60 | ≤ 118 |
| 078112361 | 12,5 ÷ 15 | 3 x 120° | 3 | ≥ 63 | ≤ 120 |
| 078112362 | 15 ÷ 17,5 | 3 x 120° | 3 | ≥ 65 | ≤ 122 |
| 078112363 | 17,5 ÷ 20 | 3 x 120° | 3 | ≥ 68 | ≤ 125 |
| 078112364 | 20 ÷ 25 | 90°-135°-135° | 7 | ≥ 75 | ≤ 132 |
| 078112365 | 25 ÷ 30 | 90°-135°-135° | 7 | ≥ 90 | ≤ 138 |
| 078112366 | 30 ÷ 35 | 90°-135°-135° | 7 | ≥ 90 | ≤ 142 |
| 078112367 | 35 ÷ 40 | 90°-135°-135° | 7 | ≥ 90 | ≤ 148 |
| 078112368 | 40 ÷ 45 | 90°-135°-135° | 10,5 | ≥ 110 | ≤ 167 |
| 078112369 | 45 ÷ 50 | 90°-135°-135° | 10,5 | ≥ 113 | ≤ 170 |
| 078112370 | 50 ÷ 60 | 90°-135°-135° | 15 | ≥ 123 | ≤ 187 |
| 078112371 | 60 ÷ 70 | 90°-135°-135° | 15 | ≥ 130 | ≤ 193 |
| 078112372 | 70 ÷ 85 | 90°-135°-135° | 15 | ≥ 145 | ≤ 213 |
| 078112373 | 85 ÷ 100 | 90°-135°-135° | 15 | ≥ 155 | ≤ 224 |
| 078110733 | 100 ÷ 125 | 3 x 120° | 27 | ≥ 105 | ≤ 194 |
| 078110735 | 125 ÷ 150 | 3 x 120° | 27 | ≥ 105 | ≤ 194 |
| 078110737 | 150 ÷ 175 | 3 x 120° | 27 | ≥ 105 | ≤ 194 |
| 078110739 | 175 ÷ 200 | 3 x 120° | 27 | ≥ 105 | ≤ 194 |

Measuring range up to 300 mm available upon request.



ETALON INTALOMETER 531, Metric Sets

Made to check through holes, blind bores and short centring shoulders. All models covering the application range up to 100 mm have sloped bolts extending beyond the front face of the measuring head.



Models from 10 to 100mm: DIN 863 T4 (Style C2) NFE 11-099



Max. perm. error for models covering the application ranges from 5 to 40 mm = 3 µm 40 to 100 mm = 4 µm 100 to 200 mm = 5 µm



Repeatability limit for models covering the application ranges from 5 to 40 mm = 3 µm 40 to 100 mm = 4 µm 100 to 200 mm = 5 µm



Measuring bolts on models from 5 to 100 mm: hardened steel. 100 to 200 mm: tungsten carbide tipped.



Protective case or carrying case



Inspection report with a declaration of conformity



Identification number



Models from 5 to 100 mm = 0,002 mm on vernier, 100 to 200 mm = 0,01 mm

| No | mm | No | Isolated instruments | mm | No | Setting rings | mm | No | Extensions | mm |
|---------------------------------|----------|-----------|----------------------|-----------|----------|---------------|----|-----------|------------|----|
| COMPOSITION OF THE SETS: | | | | | | | | | | |
| 078110592 | 5 ÷ 10 | 078112356 | | 5 ÷ 6 | 00840114 | 6 | | 078103613 | 100 | |
| | | 078112357 | | 6 ÷ 7 | 00840115 | 8,5 | | | | |
| | | 078112358 | | 7 ÷ 8,5 | | | | | | |
| | | 078112359 | | 8,5 ÷ 10 | | | | | | |
| 078110594 | 10 ÷ 20 | 078112360 | | 10 ÷ 12,5 | 00840116 | 12,5 | | 078103621 | 150 | |
| | | 078112361 | | 12,5 ÷ 15 | 00840117 | 17,5 | | | | |
| | | 078112362 | | 15 ÷ 17,5 | | | | | | |
| | | 078112363 | | 17,5 ÷ 20 | | | | | | |
| 078110596 | 20 ÷ 40 | 078112364 | | 20 ÷ 25 | 00840106 | 25 | | 078103624 | 150 | |
| | | 078112365 | | 25 ÷ 30 | 00840107 | 35 | | | | |
| | | 078112366 | | 30 ÷ 35 | | | | | | |
| | | 078112367 | | 35 ÷ 40 | | | | | | |
| 078110598 | 40 ÷ 100 | 078112368 | | 40 ÷ 45 | 00843230 | 45 | | 078104940 | 150 | |
| | | 078112369 | | 45 ÷ 50 | 00843239 | 60 | | | | |
| | | 078112370 | | 50 ÷ 60 | 00840118 | 85 | | | | |
| | | 078112371 | | 60 ÷ 70 | | | | | | |
| | | 078112372 | | 70 ÷ 85 | | | | | | |
| | | 078112373 | | 85 ÷ 100 | | | | | | |



DIN 863 T4
(Style C2)
NFE 11-099

000 0,01 mm

Tungsten carbide
tipped measuring
bolts and cone

Shipping box

Inspection report
with a declaration
of conformity

No
NO Identification
number

0,002 mm

Supplied with 1 heat
insulating sleeve
(No. 00940020),
2 keys (No. 00940001),
1 screwdriver
(No. 00862801).

TESA TRI-O-BOR

Self-centring and self-aligning internal micrometers with 3-line contact with the part being inspected.

These micrometers measure trough holes, blind bores and short centring shoulders.

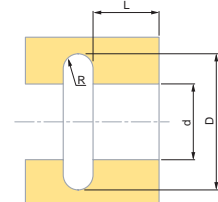
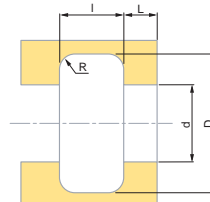
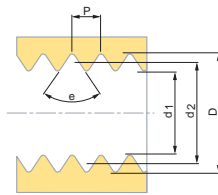
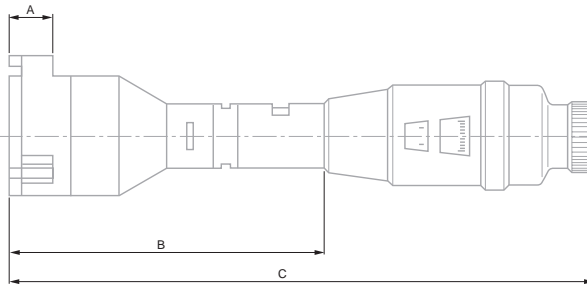
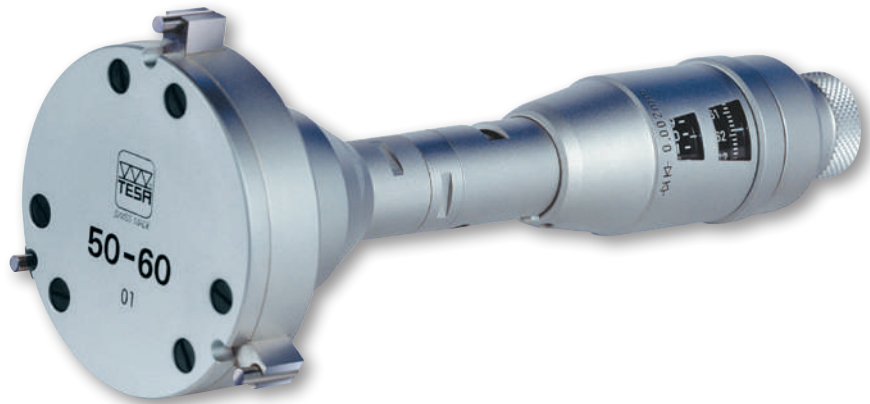

| No | | | | | | |
|----------|-----------|----|----|------|------|-------|
| | mm | µm | µm | A mm | B mm | C mm |
| 00910005 | 5 ÷ 20 | 4 | 4 | 6 | ≥ 66 | ≤ 132 |
| 00910006 | 20 ÷ 25 | 4 | 4 | 6 | ≥ 66 | ≤ 132 |
| 00910007 | 25 ÷ 30 | 4 | 4 | 6 | ≥ 66 | ≤ 132 |
| 00910405 | 30 ÷ 40 | 4 | 4 | 10 | ≥ 70 | ≤ 138 |
| 00910406 | 40 ÷ 50 | 4 | 4 | 10 | ≥ 70 | ≤ 138 |
| 00910407 | 50 ÷ 60 | 5 | 5 | 10 | ≥ 70 | ≤ 138 |
| 00910705 | 60 ÷ 70 | 5 | 5 | 18 | ≥ 78 | ≤ 147 |
| 00910706 | 70 ÷ 80 | 5 | 5 | 18 | ≥ 78 | ≤ 147 |
| 00910707 | 80 ÷ 90 | 5 | 5 | 18 | ≥ 78 | ≤ 147 |
| 00911105 | 90 ÷ 100 | 5 | 5 | 18 | ≥ 78 | ≤ 147 |
| 00911106 | 100 ÷ 110 | 6 | 6 | 18 | ≥ 78 | ≤ 147 |
| 00911107 | 110 ÷ 120 | 6 | 6 | 18 | ≥ 78 | ≤ 147 |

OPTIONAL ACCESSORY

00940000 Extension of 150 mm for TESA TRI-O-BOR



TESA TRI-O-BOR, Full Sets

Self-centring and self-aligning internal micrometers with 3-line contact with the part being inspected.

These micrometers measure through holes, blind bores and short centring shoulders.

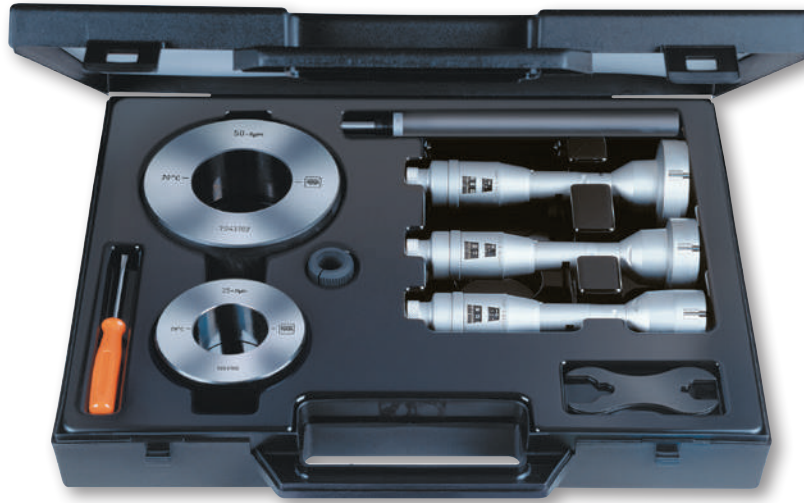

- DIN 863 T4 (Style 2) NFE 11-099
- 0,01 mm
- Tungsten carbide tipped measuring bolts and cone
- Protective case or carrying case
- Inspection report with a declaration of conformity
- Identification number
- 0,002 mm
- Supplied with 1 heat insulating sleeve No 00940020, 2 key No 00940001, 1 screwdriver No 00862801

| | | mm | Single micrometers | mm | Setting rings | mm | Extensions | mm |
|---------------------------------|-----|----------|--------------------|-----------|---------------|-----|------------|-----|
| COMPOSITION OF THE SETS: | | | | | | | | |
| 00910004 | BSC | 15 ÷ 30 | 00910005 | 15 ÷ 20 | 00840104 | 15 | 00940000 | 150 |
| | | | 00910006 | 20 ÷ 25 | 00840106 | 25 | | |
| | | | 00910007 | 25 ÷ 30 | | | | |
| 00910404 | BSD | 30 ÷ 60 | 00910405 | 30 ÷ 40 | 00840107 | 35 | 00940000 | 150 |
| | | | 00910406 | 40 ÷ 50 | 00840108 | 50 | | |
| | | | 00910407 | 50 ÷ 60 | | | | |
| 00910704 | BSF | 60 ÷ 90 | 00910705 | 60 ÷ 70 | 00840109 | 70 | 00940000 | 150 |
| | | | 00910706 | 70 ÷ 80 | 00840110 | 90 | | |
| | | | 00910707 | 80 ÷ 90 | | | | |
| 00911104 | BSG | 90 ÷ 120 | 00911105 | 90 ÷ 100 | 00840110 | 90 | 00940000 | 150 |
| | | | 00911106 | 100 ÷ 110 | 00840111 | 110 | | |
| | | | 00911107 | 110 ÷ 120 | | | | |

Extension for Depth Increase TESA TRI-O-BOR



| | |
|----------|-----------|
| | |
| 00940000 | mm 150 |



Shipping box

No
NO Identification number

SETTING STANDARDS FOR INTERNAL MICROMETERS

TESA Setting Rings and Setting Masters

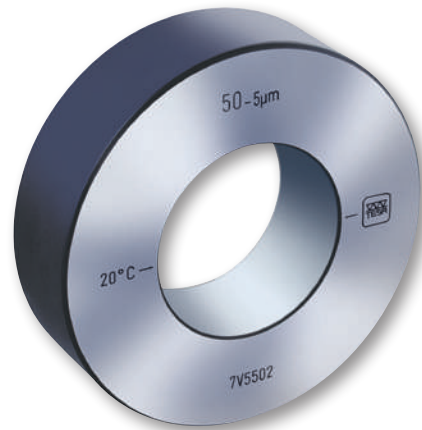

Setting ring 50 mm

Setting standard 225-275 mm

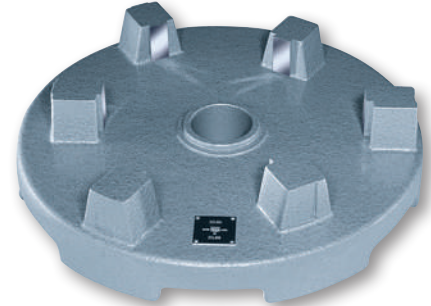

| No | ∅ | d | µm** |
|----------|----------|-----|------|
| | mm | µm* | µm** |
| 00843200 | 4 | 1,5 | 1,5 |
| 00843201 | 5,5 | 1,5 | 1,5 |
| 00840114 | 6 | 1,5 | 1,5 |
| 00840101 | 8 | 1,5 | 1,5 |
| 00840115 | 8,5 | 1,5 | 1,5 |
| 00840102 | 10 | 1,5 | 1,5 |
| 00840103 | 11 | 1,5 | 1,5 |
| 00840116 | 12,5 | 1,5 | 1,5 |
| 00840104 | 15 | 1,5 | 1,5 |
| 00840105 | 17 | 1,5 | 1,5 |
| 00840117 | 17,5 | 1,5 | 1,5 |
| 00840106 | 25 | 1,5 | 1,5 |
| 00840107 | 35 | 2 | 2 |
| 00843230 | 45 | 2 | 2 |
| 00840108 | 50 | 2 | 2 |
| 00843239 | 60 | 2 | 2 |
| 00840109 | 70 | 2 | 2 |
| 00840118 | 85 | 2 | 2 |
| 00840110 | 90 | 2 | 2 |
| 00840111 | 110 | 2,5 | 2,5 |
| 00840112 | 125 | 2,5 | 2,5 |
| 00840113 | 175 | 2,5 | 4 |
| 00843101 | 225, 275 | - | 6 |

* Making no allowance for a rim of 1 mm.

** All listed values are determined through a 2-point measurement taken at half-height of the setting ring. The measuring direction is marked with 2 strokes. The measured actual dimension is engraved on every setting master.





Measuring Instruments for Large Dimensions



TESA – THE SPECIALISTS FOR LONG LENGTHS

For large dimensions from 250 mm up to several meters, TESA offers various types of measuring instruments that have long proven their value in practical use.

Whatever the sizes, from a simple distance between two surfaces parallel to one another measurement is always a challenge. Apart from the usual influences, which are proportional to the size whilst adding to your contributions in the uncertainty budget, those due to gravity play a key role in distortion.

Large sizes in mechanical engineering generally mean dimensions in excess of 500 mm. Various measurement procedures are brought into play, using such items as large internal and external micrometers with two-point contact, periphery tapes (for outside diameters), V-bases, rotating measuring disks (rolling-contact) optical systems (triangulation with theodolite), fixed gauges (inside caliper gauges), gauge blocks combinations or adjustable telescopic gauges.

There are other methods that often call for very simple techniques, such as fixed gauges (caliper gauges), combinations of gauge blocks, or even adjustable telescopic gauges.

Here's an example of a proportional relationship. With a bore of $\varnothing 1200$ H7, the tolerance area matches 0,1 mm. Reducing both values by a factor of 100 would give a manufacturing tolerance as low as $1 \mu\text{m}$. Of course, things are not as simple, but this example gives some ideas about the proportions.





DIN 863 T4 (Style B)

Micrometer: 25 mm

Dial gauge: ± 0,22 mm

Micrometer and dial gauge: 0,01 mm

Micrometer: 0,1 mm

8 µm

Measuring bolts: Spherical and for measuring in the micrometer axis. All inserts are interchangeable

Extension: 1 spherical and 1 flat measuring face

0,5 mm

Tungsten carbide tipped

0,7 to 1N

Extension: 26 mm dia. steel tube with snap-ring system. Also with built in gauge rods.

Wooden case

Setting standard with identification number

Calibration certificate:
 • per setting standard
 • per measuring element
 • per extension

Declaration of conformity

TESA UNITEST Internal Micrometer

Measures internal dimensions in the micrometer's axis with 2-point contact with the workpiece to be checked – Optional accessories are available for inspecting centring shoulders and blind bores along with auxiliary means for external measuring.

Extensions with built-in gauge rods can be mounted on the measuring element, thus allowing any dimension within the application range to be measured, directly.

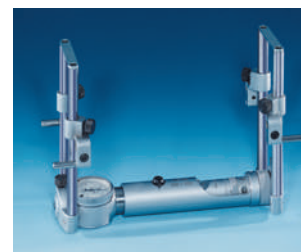

| No | = | Icon | mm | mm | µm |
|------------------------------|---|------|--------------------------------|------------------------|-----|
| 01110700 | UNITEST (SET) | Icon | Internal dimensions 200 ÷ 1400 | | |
| CONSISTING OF: | | | | | |
| No | = | Icon | mm | mm | µm |
| 01110901 | Measuring head | Icon | Internal dimensions 200 ÷ 225 | | |
| 01141001 | Setting gauge | Icon | Internal / external dimensions | 200 | |
| 01110801 | Extension | Icon | | 25 | 0,7 |
| 01110802 | Extension | Icon | | 50 | 1 |
| 01110804 | Extension | Icon | | 100 | 1,5 |
| 01110808 | Extension | Icon | | 200 | 2,5 |
| 01110812 | Extension | Icon | | 300 | 3,5 |
| 01110820 | Extension | Icon | | 500 | 5,5 |
| 01160901 | Screwdriver | | | | |
| 01162302 | Case for Unitest | | | | |
| OPTIONAL ACCESSORIES: | | | | | |
| 01160701 | Pair of tungsten carbide tipped measuring bolts for blind bores | | | | |
| 01162301 | Auxiliary elements for external measurement | | | Measuring depth: ≤ 10 | |
| 01140801 | Suspension device, complete | | | Measuring depth: ≤ 100 | |



TESA UNIMASTER Universal Measuring Instrument

TESA UNIMASTER Universal Measuring Instrument provides the features necessary for direct measurement of specially large internal and external dimensions. TESA UNIMASTER is similar to internal micrometers with two-point contact with the workpiece being measured. Measures any dimension within the extended application range directly by simply adding the needed extensions with built-in gauge blocks to the measuring element.

Accurate, robust and easy-to-handle – Can be used either vertically or horizontally with a constant measuring force – Incorporates a lever-type dial test indicator that clearly shows the culmination point – Ensures stable measuring owing to both a negligible deflection and thermal protection on each extension.

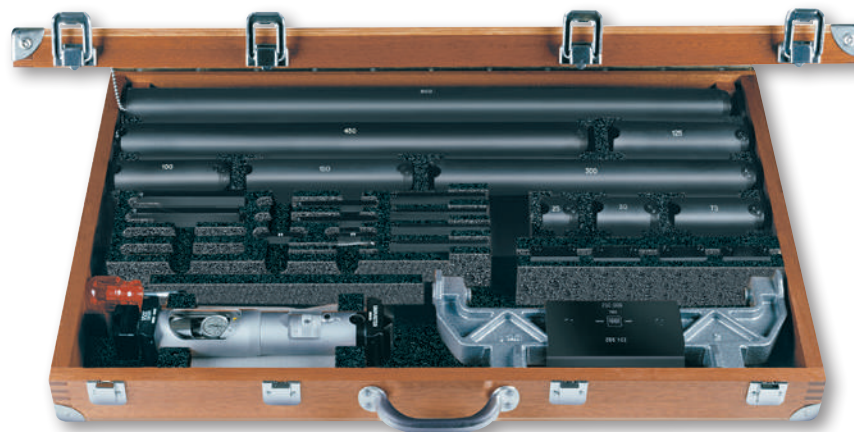
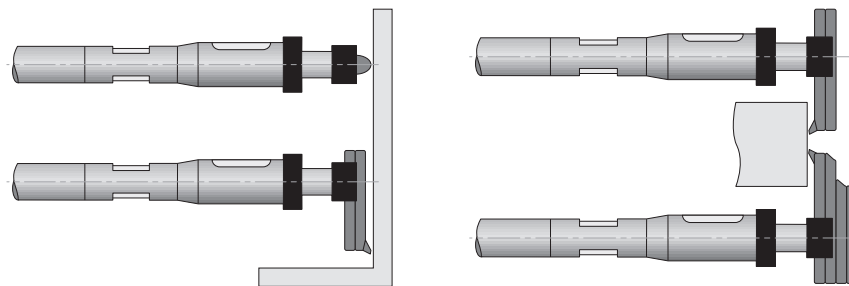
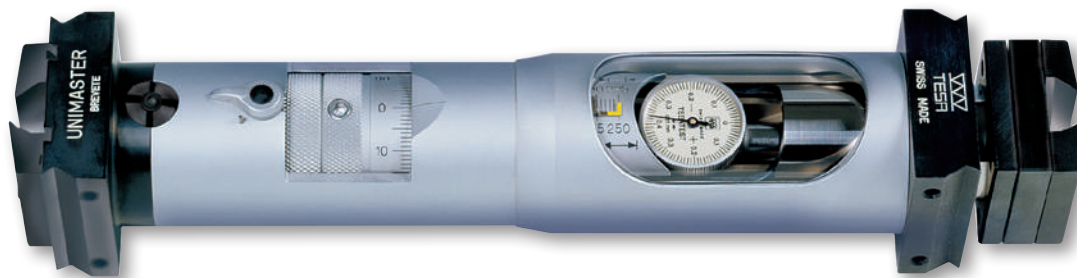

- DIN 863 T4 (Style B)
- Micrometer: 25 mm
- Dial test indicator: ± 0,4 mm
- Micrometer and dial test indicator: 0,01 mm
- 5 µm
- One spherical and one flat measuring faces
- 1 mm
- Tungsten carbide tipped
- 15 to 20 N measuring force reversible between internal and external directions
- Measuring bolts supplied in pairs:
 - No. 01110203 for internal measuring in the micrometer axis.
 - No. 01110205 for internal/external measuring, meas. depth up to 60 mm from the lower edge of the micrometer.
 - No. 01110208, extra-rigid for external measuring, meas. depth up to 75 mm from the lower edge of the micrometer.
- Extension: 38 mm dia. diameter steel tube with snap ring system. Built-in gauge rod.
- Mobile ball-bearing anvil under spring pressure.
- Wooden case
- Measuring element and setting standard with identification number
- Calibration certificate:
 - per setting standard
 - per measuring element
 - per extension
- Declaration of conformity



| No | = | | | | | |
|------------------------------|---|--------------------------|--------------------------|-----------------------|--------------------|-----------------------------------|
| | | mm | mm | | | |
| 01110000 | TESA UNIMASTER metric full | Int. dim. 250 ÷ 1475* | Ext. dim. 225 ÷ 1450* | | | |
| CONSISTING OF: | | | | | | |
| No | = | | | | | |
| | | mm | mm | mm | mm | µm |
| 01110300 | Measuring element UNIMASTER | Int. dim. 250 ÷ 275 | Ext. dim. 225 ÷ 250 | | | |
| 01110203 | Set measuring arms interior dimensions | | | | | |
| 01110205 | Set measuring arms for interior and exterior dimensions, length 75mm | | | 75 | | |
| 01110208 | Set measuring arms for interior and exterior dimensions, length 100mm | | | 100 | | |
| 01110501 | Setting gauge | | | Int. dim.: 250 | Ext. dim. : 225 | |
| 01110101 | Extension | | | 25 | | 0,7 |
| 01110102 | Extension | | | 50 | | 1 |
| 01110103 | Extension | | | 75 | | 1,2 |
| 01110104 | Extension | | | 100 | | 1,5 |
| 01110105 | Extension | | | 125 | | 1,5 |
| 01110106 | Extension | | | 150 | | 2 |
| 01110112 | Extension | | | 300 | | 3,5 |
| 01110118 | Extension | | | 450 | | 4,5 |
| 01110124 | Extension | | | 600 | | 6,5 |
| 01130001 | Special screwdriver | | | | | |
| 01110401 | Set of suspension accessories (4 brackets together with 4 clamps) | | | | | |
| 01112401 | Wooden case for complet set | | | | | |
| OPTIONAL ACCESSORIES: | | | | | | |
| 01110140 | Extension 1000 mm | | | 1000 | | 10 |
| 01162001 | Anvils for internal/external dimensions and throats | | | Measuring depth: ≤ 20 | | Tungsten carbide inserts: Ø 4 x 7 |
| 01160001 | Roller (2 items are needed) | | | | | |

*Using 3 extensions at the very most.

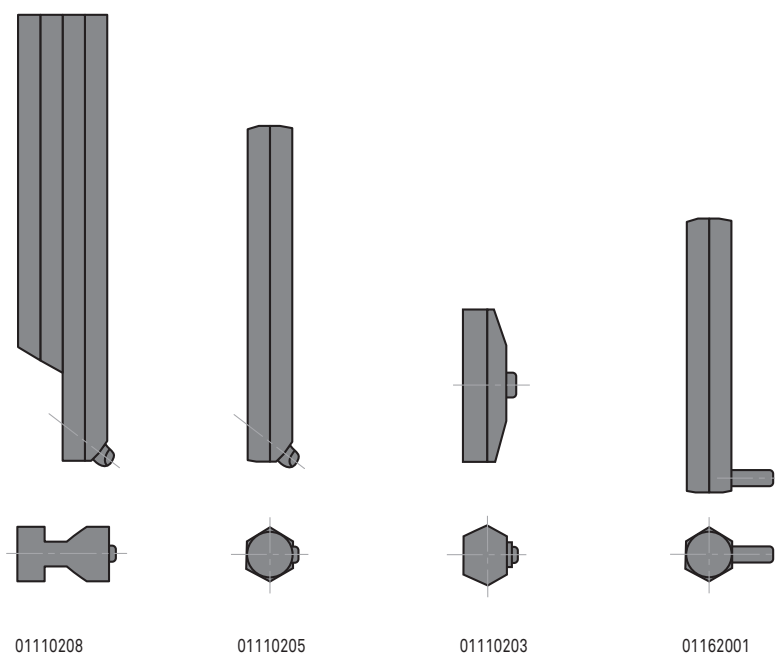

01110208

01110205

01110203

01162001



TESA INOTEST Comparative Measuring Instrument

Allows for comparative measurement of large internal or external dimensions. Consists of a measuring element with interchangeable inserts as well as a set of extensions. Since there is no material measure, the indication is set using a separate standard that can either be a gauge block, setting ring or horizontal measuring bench.

Measuring inserts for inspection in the tool axis, or offset inserts – Vertical or horizontal position of use – Integrated dial gauge to show the culmination point – Constant measuring force – Extensions with heat insulating grip.

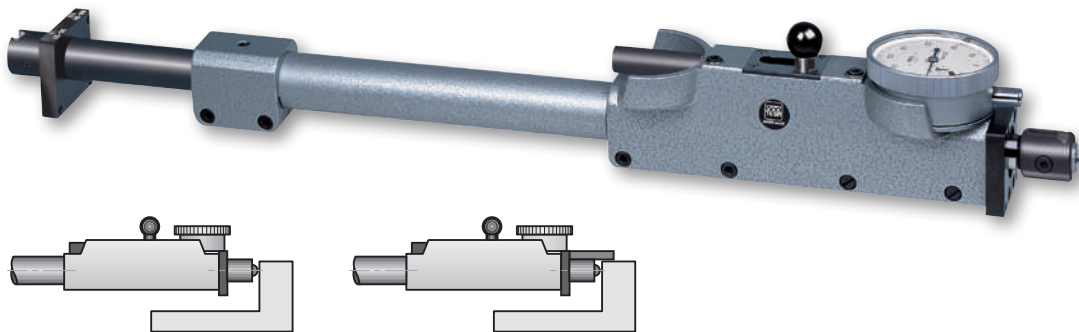
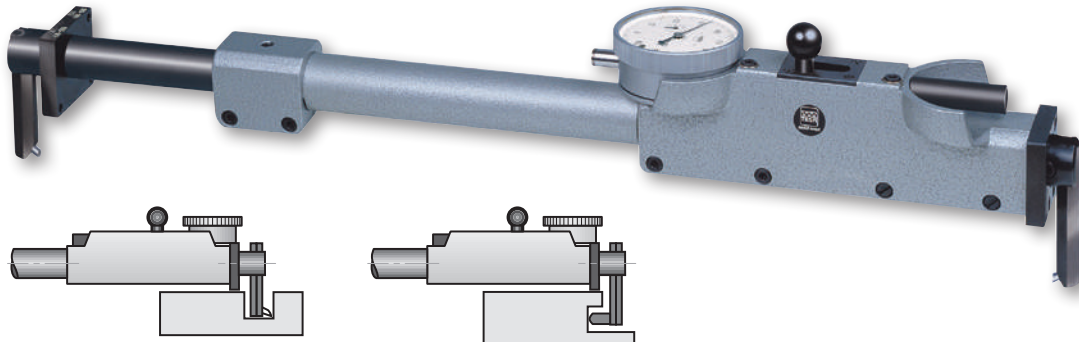
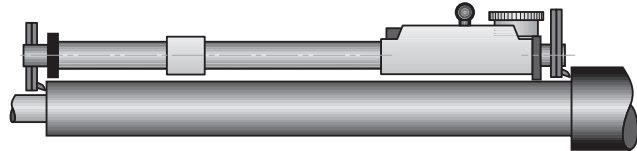

10 mm



0,01 mm



Measuring bold and extension: Tungsten carbide tipped



4 tp 7N. Reversible probing direction to allow both internal and external measuring.



Watertight dial gauge No. 01470104 and 01480100



Measuring bolts supplied in pairs:
 • No. 01131901 for internal measuring in the instrument axis.
 • No. 01131902 for internal/external measurement, measuring depth up to 30 mm from the lower edge of the tool



Extension: 25 mm dia. steel tube. 19 mm dia telescopic tube that can be clamped



Mobile ball-bearing anvil under spring pressure, 10 mm travel



For additional technical data: see chapter Indicators



Plastic case



Dial gauge with serial number



Declaration of conformity



Dial gauge with inspection report



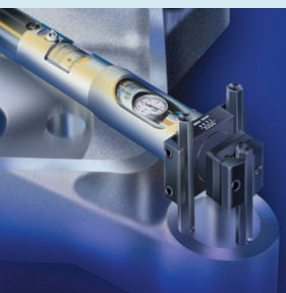

| No | = | | |
|-----------------------|---|--------------------------|--------------------------------------|
| | | mm | mm |
| 01111900 | TESA INOTEST complete set | Int. dim. 275 ÷ 1025 | Ext. dim. 250 ÷ 1010 |
| CONSISTING OF: | | | |
| No | = | | |
| | | mm | |
| 01112301 | Measuring element INOTEST | | |
| 01131901 | Pair of inserts for internal measuring | | |
| 01131902 | Pair of inserts for internal and external measuring, length 60 mm | 60 | |
| 01132001 | Set of 4 mounting rods | Ø 7 x 40 | |
| 00160101 | 3 insulating grips (reference code is for 1 item) | | |
| 01112001 | Extension 250 ÷ 310 mm | Int. dim.: 275 ÷ 335 | Ext. dim.: 250 ÷ 310 |
| 01112002 | Extension 300 ÷ 410 mm | Int. dim.: 325 ÷ 435 | Ext. dim.: 300 ÷ 410 |
| 01112003 | Extension 400 ÷ 610 mm | Int. dim.: 425 ÷ 635 | Ext. dim.: 3400 ÷ 610 |
| 01112004 | Extension 600 ÷ 1010 mm | Int. dim.: 625 ÷ 1035 | Ext. dim.: 600 ÷ 1010 |
| 01162303 | Case INOTEST | | |
| OPTIONAL ACCESSORIES: | | | |
| 01141901 | Extension 500 mm | 500 | |
| 01141902 | Extension 1000 mm | 1000 | |
| 01162001 | Carbide measuring inserts for throats | Measuring depth: ≤ 20 | Tungsten carbide inserts: Ø 4 x 7 |
| 01161900 | Device for small dimensions, Inotest | Int. dim. 35 ÷ 280 | Ext. dim. 15 ÷ 255 |

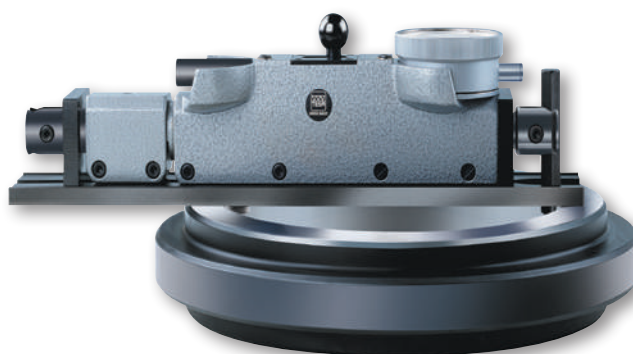

ETALON 532 Internal Micrometer

This micrometer is designed for measurements with 2-point contact.

Extensions with built-in gauge rods can be used to increase the measuring range – Stiff screw coupling.



| | | | | | | | |
|-----------|--|----|-----------|-----------|-----------|-----------|-----------|
| Full set: | | | 072109101 | 072109107 | 072109108 | 072109117 | 072109128 |
| | | mm | 50 ÷ 170 | 50 ÷ 290 | 50 ÷ 530 | 50 ÷ 1010 | 50 ÷ 1510 |

COMPOSED BY:

| | | mm | mm | µm | | | | | |
|-----------|-----------------------|---------|-----|-----|---|---|---|---|---|
| 072103576 | Micrometrical element | 50 ÷ 65 | 3 | | • | • | • | • | • |
| 072103585 | Extention | | 15 | 1,5 | • | • | • | • | • |
| 072105462 | Extention | | 30 | 1,5 | • | • | • | • | • |
| 072109030 | Extention | | 60 | 2 | • | • | • | • | • |
| 072103586 | Extention | | 120 | 2 | | • | • | • | • |
| 072109055 | Extention | | 240 | 3 | | | • | • | • |
| 072109066 | Extention | | 480 | 3,5 | | | | • | • |
| 072109089 | Extention | | 500 | 3,5 | | | | | • |

ROCH Metric Periphery Tapes

Steel tapes with a dual graduation for measuring external circumferences and diameters of cylindrical parts on machines and other fittings – Suitable for malleable parts such as plastic tubing – Used for inspecting tanks or boilers – Also designed for checking steel or concrete pipes, rims, tires etc.

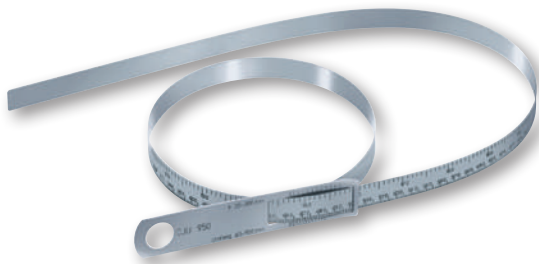

| | Diameter, mm | Circumference, mm | mm |
|------------|--------------|-------------------|------|
| 0951750222 | 20 ÷ 30 | 60 ÷ 950 | 0,15 |
| 0951750223 | 300 ÷ 700 | 940 ÷ 2200 | 0,20 |
| 0951750224 | 700 ÷ 1100 | 2190 ÷ 3460 | 0,20 |
| 0951750225 | 1100 ÷ 1500 | 3450 ÷ 4720 | 0,25 |

- Factory standard
- 15 mm
- 0,01 mm
- Spheric (R = 15 mm)
- 29 mm
- 0,5 mm
- Tungsten carbide tipped
- Reference gauge rods
- Wooden case
- Declaration of conformity

- Factory standard
- See table
- 0,1 mm
- 16 x 0,2 mm type section
- Steel band
- Shipping packaging
- Declaration of conformity

Dial gauges – Electronic and Analogue



EASY-TO-USE AND VERSATILE

For more than 50 years we have been producing and distributing a wide range of easy-to-use and versatile dial gauges. Our experience allows us to offer a wide choice of different models.

- Electronic indicators with combined analogue/digital display using the most up-to-date technology.
- Mechanical dial gauges equipped with high-precision movements and double-action shockproof mechanisms. Measuring spans up to 100 mm.

CHOICE OF DIAL GAUGE OR ELECTRONIC INDICATOR

- Digital indication provides error-free reading of the measured value. There is no need to read fractions of scale divisions.
- Analogue indication offers the advantage of being able to smoothly adjust the increase or decrease of the dimension to be measured on the workpiece. This type of indication is best suited for dynamic measurements such as determining axial and radial runout errors.
- Electronic indicators provide many additional functions compared to the mechanical models. For more information, refer to the section on electronic indicators.
- The inspection of axial and radial runout errors frequently requires the use of instruments with the lowest hysteresis characteristic. Our electronic indicators, precision dial gauges and dial test indicators meet this requirement.
- In order to significantly reduce the effect of systematic errors, it is recommended to carry out comparative measurements. Only deviations from the nominal dimension will be displayed. High precision, small range electronic indicators are the ideal instruments for these types of measurements.
- These same instruments also enable avoiding major errors in reading millimetres.

STANDARDS AND DEFINITIONS

The international ISO 463:2006 standard replaces national standards dealing with mechanical dial gauges. All the same, new definitions and standard requirements pertaining to measuring procedures, although valid, imply changes in design and metrological characteristics, which cannot be entirely indicated in this catalogue. This standard, is defined in the matrix "Product Specification (GPS) - dimensional measuring instruments". It only defines the requirements for the most important characteristics.

Therefore, all tolerance limits indicated in this catalogue which refer to metrological characteristics are based on our own internal standards.

Electronic indicators and short range precision indicators. Definitions used in this section:



Total permissible error in 1 measuring direction over the entire measuring range within the partial measuring range

in the 2 measuring directions



Repeatability limit



Max. hysteresis

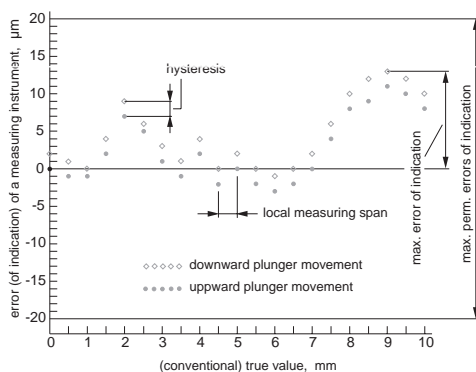

Mechanical dial gauges.

Definitions used in this section for the maximum permissible errors of a metrological characteristic (MPE):



Deviation span (error of indication within the measuring range)

Deviation span (error of indication) within the partial measuring range

Total deviation span (error of indication within the measuring range)



Repeatability limit (reliability) of indication



Hysteresis of indication

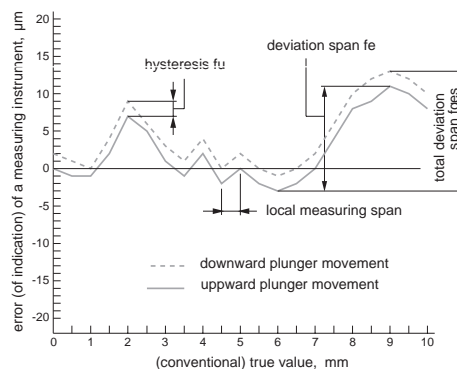



Resolution 0,01 mm = ±0,25 mm
Resolution to 0,001 mm = ±0,025 mm

6-decade LC display field, plus minus sign

Digit size 10 x 5 mm (H x L)

Combined analogue and numerical display

Glass scale with incremental divisions, capacitive

MI or MIE type: metric/inch conversion

≤ 2 N

≤ 2 m/s

Full-metal housing with front face in polyamide. Stainless steel plunger. M2,5 mounting thread for measuring insert.

RS232, opto-coupled

3V lithium battery type CR2032

1 year to 2 years

10°C to 40°C

-10°C to 60°C

~80 %

EN 50081-1
EN 50082-1

150 g

Transport case with 1 lithium battery 01961000

Identification number

Inspection report with declaration of conformity

TESA DIGICO 205 / 305

- Dual LC Display, digital and analogue.
- Mechanical tolerance markers.
- Dimensions according to DIN 878.

Main functions

ON/Auto OFF – Data output – Counting sense reversal – Keypad lock.

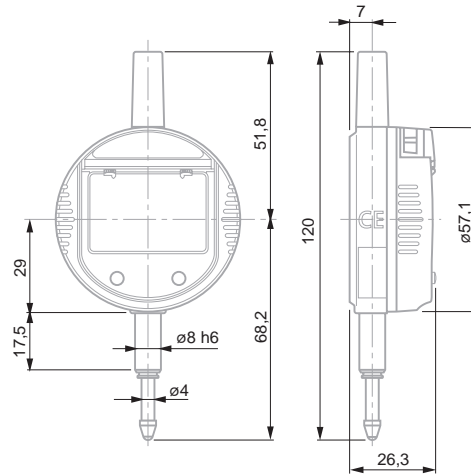

| No | = | | | | | | |
|----------|---------------|------|-----|-------|---------|----|----|
| | | mm | in | mm | in | µm | µm |
| 01930230 | DIGICO 205 MI | 12,5 | 0.5 | 0,01 | 0.0005 | 20 | 10 |
| 01930231 | DIGICO 305 MI | 12,5 | 0.5 | 0,001 | 0.00005 | 8 | 2 |



TESA DIGICO 400 / 500

- Measuring modes ABS/REL.
- Dual LC Display, digital and analogue
- Rotation through 270° of display and key functions.
- Mechanical tolerance marks.
- Graphical display of tolerance limits.

Measuring functions and modes

ON - Auto OFF - PRESET mode - Tolerance mode - Data output - Counting sense reversal - Keypad lock - Metric/Inch units - Full RESET.

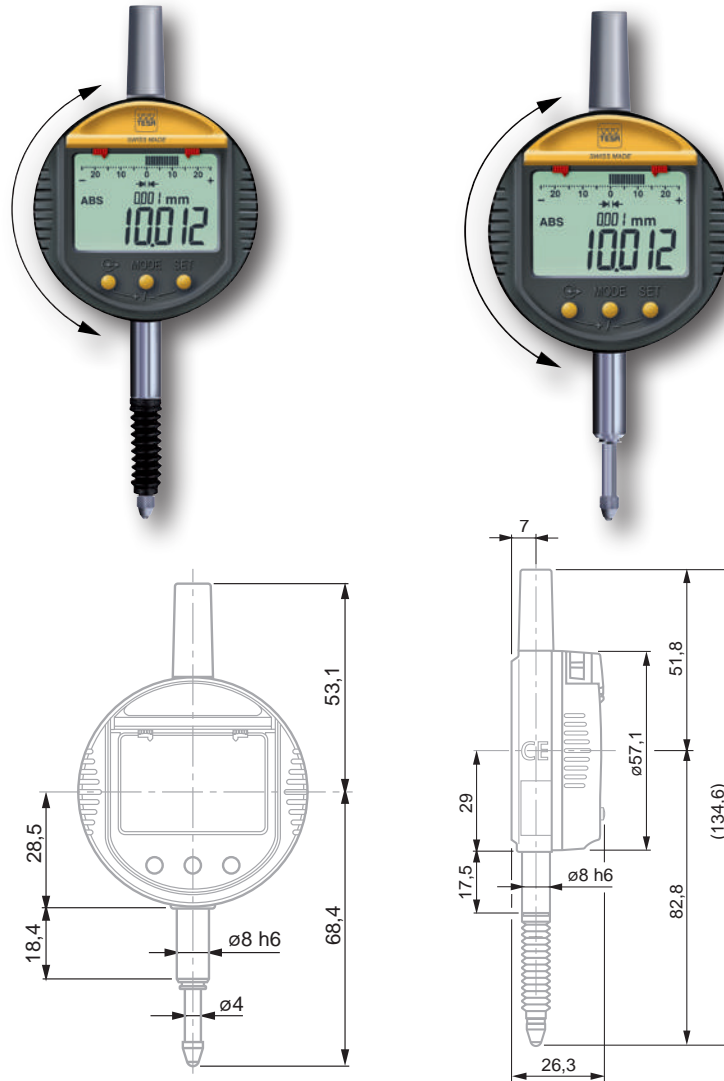

- Resolution 0,01 mm = ±0,25 mm Resolution 0,001 mm = ±0,025 mm
- 6-decade LC display field plus minus sign
- Digit size 10 x 5 (H x L)
- Combined analogue and numerical display
- Glass scale with incremental divisions, capacitive
- Conversion mm/in
- Measuring force: < 2 N
- ≤ 2 m/s
- Full-metal housing, front face in polyamide, Stainless steel plunger, M2,5 mounting thread for measuring insert.
- RS232, opto-coupled
- 3V lithium battery, type CR2032
- 1 year to 2 years
- 10°C to 40°C
- 10°C to 60°C
- 80 %
- EN 50081-1 EN 50082-1
- Shipping case including one lithium battery 01961000
- Identification number
- Inspection report with declaration of conformity

| No | = | | | | | | | | |
|----------|---------------------------|------|-----|-------|---------|----|----|------|-----|
| 01930241 | DIGICO 410 MI | 25 | 1 | 0,01 | 0.0005 | 20 | 10 | - | 162 |
| 01930255 | DIGICO 505 MIP, protected | 12,5 | 0.5 | 0,001 | 0.00005 | 4 | 2 | IP62 | 150 |



Resolution 0,01 mm
= ± 0,25 mm Resolution
0,001 mm =
± 0,025 mm

6-decade LC display
field plus minus sign

Digit size 10 x 5 mm
(H x L)

Combined analogue
and numerical
display

Glass scale with in-
cremental divisions,
capacitive

Conversion mm/in

Measuring force:
< 2 N

≤ 2 m/s

Full-metal housing
with front face in
polyamide. Stainless
steel plunger.
M2,5 mounting
thread for mea-
suring insert.

RS232,
opto-coupled

3V lithium battery,
type CR2032

1 year to 2 years

10°C to 40°C

-10°C to 60°C

80 %

EN 50081-1
EN 50082-1

Transport case with
1 lithium battery
01961000

Identification
number

Inspection report
with eclaration of
conformity

TESA DIGICO 600

- Measuring modes ABS/REL.
- Dual LC Display.
- Display rotation through 270°. Same goes for the key functions.
- Mechanical tolerance marks.
- Graphical display of tolerance limits.

Measuring functions and modes

ON – Auto OFF – PRESET mode – Tolerance mode – Measured value storage

- Max • Min • Max-Min (TIR) – Data output – Counting sense reversal – Keypad lock – Metric/Inch units – Full RESET.

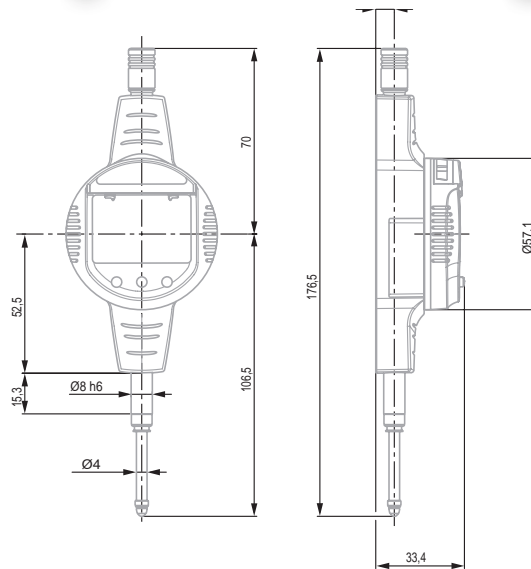

| No | = | | | | | | | |
|----------|---------------|------|-----|-------|---------|---|---|-----|
| 01930256 | DIGICO 605 MI | 12,5 | 0,5 | 0,001 | 0.00005 | 4 | 2 | 150 |
| 01930257 | DIGICO 610 MI | 25 | 1 | 0,001 | 0.00005 | 5 | 2 | 162 |



TESA DIGICO 705

For use with 2-point contact bore gauges. Allows setting of the dial gauge to the smallest setting ring value.

- Same functions as DIGICO 600.



- Resolution to 0,01 mm = ± 0,25 mm
Resolution 0,001 mm = ± 0,025 mm
- 6-decade LC display field, plus minus sign
- Digit size 10 x 5 mm (H x L)
- Combined analogue and numerical display
- Glass scale with incremental divisions, capacitive
- Conversion mm/in
- Measuring force < 2 N
- ≤ 2 m/s
- Full-metal housing with front face in polyamide. Stainless steel plunger, M2,5 mounting thread for the measuring insert.

| | | | | | | | | |
|----------|---------------|------|-----|-------|---------|---|---|-----|
| | | | | | | | | |
| 01930258 | DIGICO 705 MI | 12,5 | 0.5 | 0,001 | 0.00005 | 4 | 2 | 150 |

- RS232, opto-coupled
- 3V lithium battery, type CR2032
- 1 to 2 years
- 10°C to 40°C
- 10°C to 60°C
- 80 %
- EN 50081-1 EN 50082-1
- Transport case with 1 lithium battery 01961000
- Identification number
- Inspection report with declaration of conformity

Accessories for TESA DIGICO 200 – 700

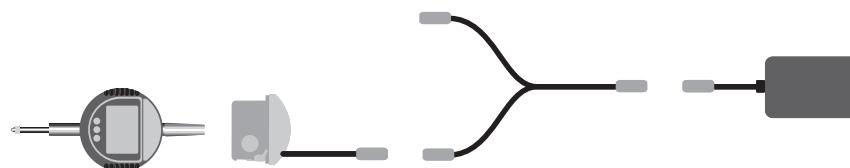

| | | |
|----------|--|---|
| | | |
| 01962002 | | External power supply |
| 01961000 | | Lithium battery, 3V, CR2032 |
| 04761054 | | Battery charger 100 ÷ 200 VAC / 50 ÷ 60 Hz, 6,6 Vdc, 750 mAh supplied without power cable |
| 04761055 | | Cable EU for charger 0471054 |
| 04761056 | | Power cable US for charger 0471054 |

- Measuring inserts, see chapter "Measuring inserts for dial gauges, axial probes and other hand tools".
- Backs and retraction devices, see chapter "Devices for plunger retraction" and "Backs for Dial Gauges".
- Connectivity, see corresponding chapter.

- According to selected tolerances
- 30,4 mm (DIGICO 1) or 60,4 mm (DIGICO 2)
- 40 mm scale length
- 25 divisions
- According to selected tolerances
- 6 decades plus minus sign
- See table
- 9 x 4,5 mm digit size (H x W)
- LC display with backlight
- Incremental glass scale
- Metric/inch conversion
- DIGICO 1: 2 µm
DIGICO 2: 3 µm
- 1 µm
- 1 µm
- See table for measuring forces
- DIGICO 1: max. 1 m/s
DIGICO 2: max. 2 m/s
- Plunger guided on a plain bearing M2,5 mounting thread for measuring insert.
- RS232
- 3,6 V lithium battery or mains adaptor
- ≈ 1000 h with lithium battery
- 0,002%/°C
- 10°C to 40°C
- 10°C to 50°C
- DIGICO case in standard execution: IP54 (IEC 60529)
-
- 290 g (DIGICO 1)
310 g (DIGICO 2)
Moved mass through the plunger:
28 g (DIGICO 1)
27 g (DIGICO 2)
- Supplied in transport packing with 1 lithium battery
01960007
1 lift lever 01960005
- Identification number
- Inspection report with a declaration of conformity

TESA DIGICO 1 / 2

These two indicators are remarkable for their multiple simple functions, long measuring travel and high accuracy.

- Analogue/digital display combined with the possibility of orienting the analogue display in different positions.
- Zero setting at any point within the measuring span.
- Data input via the keypad.
- Counting direction reversible.
- Entry of limit values for classification through displayed symbols. Additional green, red or amber coloured background whenever the instrument is connected to mains.
- Storage of measured values through the functions: "Maximum value", "Minimum value" or "Maximum value minus minimum value".

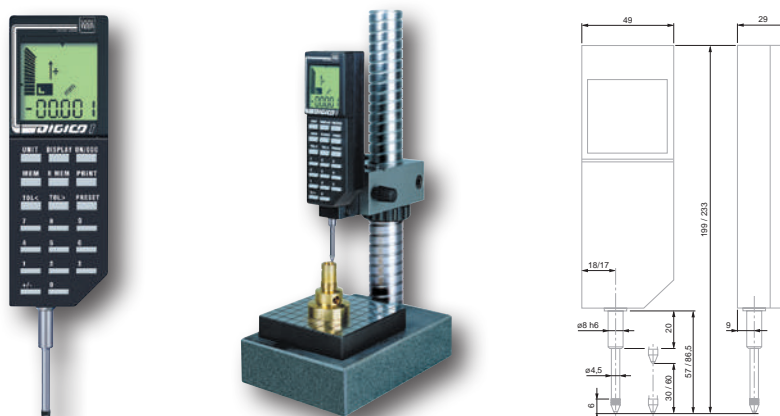

| No | = | | | | |
|----------|----------|----|------|-------|---------|
| | | mm | in | mm | in |
| 01930000 | DIGICO 1 | 30 | 1.18 | 0,001 | 0.00005 |
| 01930001 | DIGICO 2 | 60 | 3.36 | 0,001 | 0.00005 |

OPTIONAL ACCESSORIES:

- 04761037 Mains adaptor 230V for DIGICO 1 or 2
- 04761057 Mains adaptor 110V for DIGICO 1 or 2
- 01960007 3.5 V lithium battery, LR6, AA
- 01960005 Bottom mounted lift lever
- 04768000 Hand switch for manually triggering data transfer.
Jack plug connector, 1,8 m
- TESA SPC PRINTER printer
- TESATRONIC TT display units

| Force de mesure | | |
|--|-----------------|-----------------|
| | DIGICO 1 | DIGICO 2 |
| Measuring force* close to measuring plunger stop | | |
| - Bottom | 0.85 N ± 0.15 N | 0.90 N ± 0.20 N |
| - Top | 1.10 N ± 0.20 N | 1.45 N ± 0.25 N |
| Hysteresis* | 0.10 N | 0.15 N |

* Valid with indicator in vertical position, measuring plunger oriented downwards and in static measurement.



TESA DIGICO 12

Designed to operate in a rugged environment, resistant to spray of liquids (IP65) – 44 mm dial diameter – Provides the advantages of mechanical precision with digital reading

TESA DIGICO 12 – Standard

- 44 mm dial casing diameter.
- Resistant against cutting oils and coolants (IP65).
- RS232 SIMPLEX data output combined with external power supply.
- Inductive measuring system, patented.
- Choice between absolute "ABS" and relative "REL" measuring modes.
- Digital display.
- Setting of PRESET value (± 130 mm).
- Inverse measuring direction.
- Direct conversion of metric/inch units.
- Automatic shutdown.

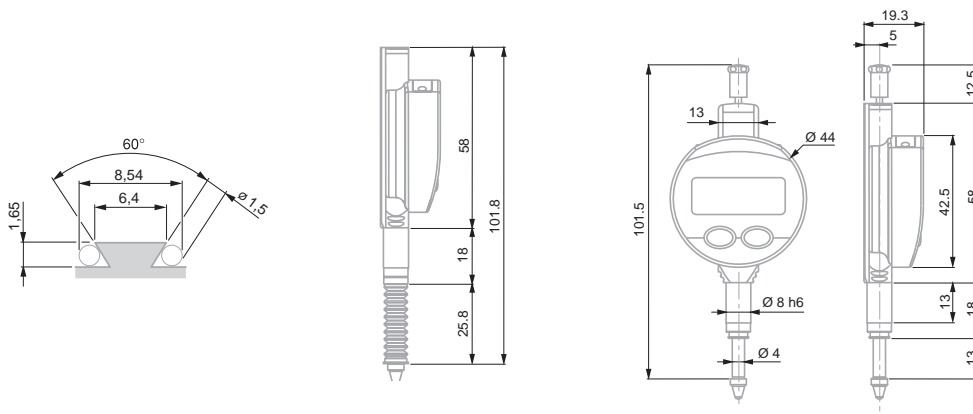

| No | mm | in | mm | in | Protection bellows | IP65 |
|----------|------|-----|-------|---------|--------------------|------|
| 01930130 | 12,5 | 0.5 | 0,01 | 0.0005 | | IP65 |
| 01930132 | 12,5 | 0.5 | 0,001 | 0.00005 | | IP65 |
| 01930131 | 12,5 | 0.5 | 0,01 | 0.0005 | With | IP65 |
| 01930133 | 12,5 | 0.5 | 0,001 | 0.00005 | With | IP65 |

- Switzerland
- 5-digit LC display + sign
- Digit height 6 mm
- 20 μ m
- Repeatability: 5 μ m
- 0,5 to 0,9 ($\pm 0,15$) N
- Max. 2 m/sec
- Number of measurements per second: 7
- Zero setting of display
- RS232
- 3 V lithium battery, type CR 3032
- Battery life > 3500 hours
- Working temperature range: 5°C to 40°C
- Protection level: IP65 (CEI 629)
- EN 61326-1
- 70 g
- Supplied in transport packing with 1 lithium battery, type CR 2032 (No 01961000)
- Identification number
- Declaration of conformity
- Models 0,01 mm with report, models 0,001 mm without report

- +
- LCD, 5 digits + sign
- Digit height: 6 mm
- Max. permissible error: 4 µm
- Repeatability limit: 2 µm
- 0,4 to 0,75 (± 0,15) N
- Max. 2 m/sec
- Number of measurements per second: 9
- Zero-setting of display
- RS232
- 3 V lithium battery, type CR 2032
- Battery life: > 4000 hours
- Working temperature range: 5°C to 40°C
- IP65 (CEI 529)
- EN 61326-1
- 70 g
- Supplied in transport packing with 1 lithium battery, type CR 2032 (No 01961000)
- Identification number
- Inspection report with a declaration of conformity

TESA DIGICO 12 - HP

- High precision measuring system.
- Resistant to cutting oils and coolants (IP65).
- Combined analogue/digital display.
- Analogue reading from ±0.025 to ±1.25 mm.
- NOR/MIN/MAX/MAX-MIN measuring modes.
- 44 mm dial casing diameter.
- RS 232 data output combined with external power supply.
- Inductive measuring system, patented.
- Zero-setting of display.
- Direct conversion of metric/inch units.
- Shut down: either automatic or blocked.

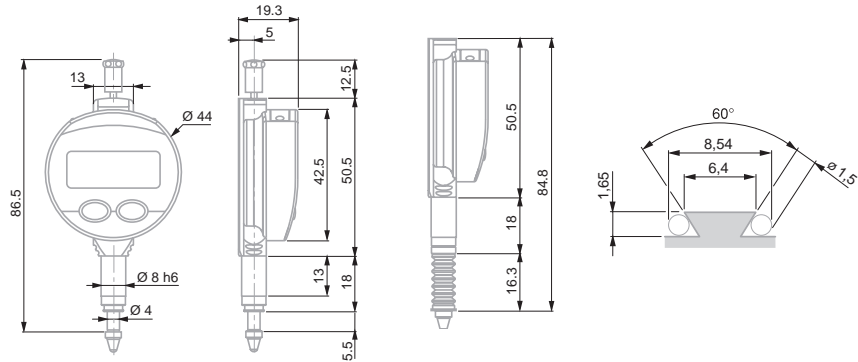

| No | | | | | Protection bellows | |
|----------|---|-------|-------|---------|--------------------|------|
| 01930134 | 5 | 0.210 | 0,001 | 0.00005 | Without | IP65 |
| 01930135 | 5 | 0.210 | 0,001 | 0.00005 | With | IP65 |

Accessories for TESA DIGICO 12

| No | = |
|----------|---|
| 03238013 | Mounting lug |
| 01961012 | Upper lift lever |
| 01960005 | Bottom mounted lift lever |
| 04761060 | RS 232 cable with external power supply |
| 01961000 | Lithium battery, 3V, CR2032 |

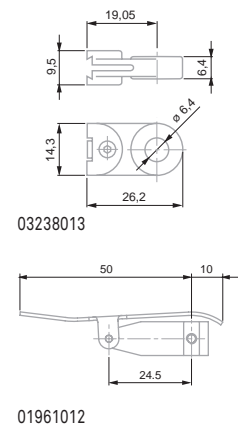

ETALON HP

High precision comparators

ETALON with short measuring travel

The ultimate in high precision.

Remarkably reliable, even when constantly used for series inspection – Specially designed for comparative measurements requiring a very low measurement uncertainty – Measures axial and radial runouts with very low hysteresis.

- Shockproof movement. Lever and gear transmission system. Long dead travel.
- Non-reflecting dial for easy readout.
- Measuring travel limited to less than one revolution of pointer. No possibility of reading errors.
- Fine adjustment with protective knob to prevent accidental displacement of the pointer.

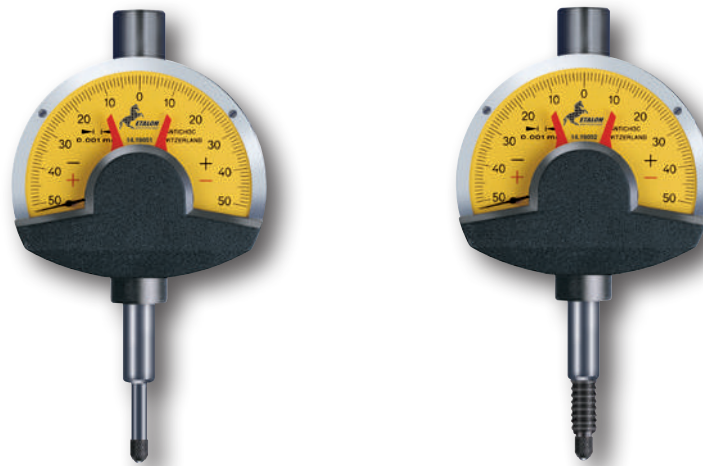

- DIN 879-1 Dimensions according to EN ISO 463
- Full-metal dial casing. Stainless steel plunger, hardened.
- ≈1 N
- Measuring plunger on ball-bearings
- Adjustable tolerance markers. Coupling thread for retraction cable. M2,5 thread for measuring insert
- 1 measuring insert already mounted, steel ball tip Ø 3.175 mm. 1 retraction cable.
- Plastic case
- Declaration of conformity

| 01419051 | 0,1 | 0,001 | 3,0 | 50 ÷ 0 ÷ 50 | ● | 62 | - |
|----------|-----|-------|-----|-------------|---|----|------|
| 01419052 | 0,1 | 0,001 | 3,0 | 50 ÷ 0 ÷ 50 | ● | 62 | IP54 |

Accuracy

| | |
|--|--|
| | 0,001 mm |
| | Max. perm. errors in one direction throughout the measuring range, G_e |
| | 1 μ m |
| | over any selected local range including 10 scale divisions, G_t |
| | 0,7 μ m |
| | in both measuring directions throughout the total measuring range, G_{ges} |
| | 1,2 μ m |
| | Repeatability limit, r_w |
| | 0,5 μ m |
| | Max. hysteresis, f_u |
| | 0,5 μ m |

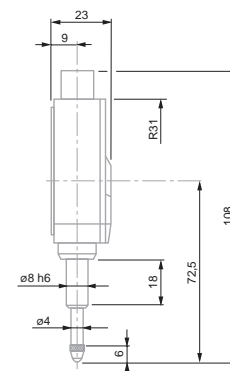

DIAL GAUGES – PREMIUM QUALITY

The TOP quality of our dial gauges guarantee the use of the best and most wear-resistant materials in order to ensure that the most demanding metrological criteria are respected along with a product life that exceeds all other dial gauges

Dial Ø 40 mm – Reading 0,01 mm

Precision dial gauges

These precision dial gauges combine excellent metrological properties with extra-long life.

- Smooth and regular travel, entirely jewel-mounted movement.
- Full-metal dial casing and bezel.
- Shockproof mechanism in both directions of plunger movement.
- Non-reflecting dial.
- Swiss-made.



01410210

353

353E

- EN ISO 463 Factory standard
- Rotating dial. With or without dial lock for standard models
- 0,01 mm
- Full-metal dial casing. Mounting shank and plunger in hardened stainless steel
- See table for tolerance limits
- With or without shockproof mechanism
- Adjustable tolerance markers. Thread M2,5 for measuring insert
- Measuring insert with 3 mm dia. ball tip already mounted
- Cardboard box
- Identification number
- Inspection report with a declaration of conformity

| No | = | | | | | | | | |
|----------|------------------|----|-----|------|-----|-------------|---|---|------|
| | | mm | mm | mm | mm | | | | N |
| 01410210 | TESA YR | 5 | 5,4 | 0,01 | 0,5 | 0 ÷ 25 ÷ 50 | ● | ● | |
| 01416013 | MERCER X185-1 | 5 | 5,4 | 0,01 | 0,5 | 0 ÷ 25 ÷ 0 | – | ● | |
| 01416014 | MERCER 186-1 | 5 | 5,4 | 0,01 | 0,5 | 0 ÷ 25 ÷ 50 | – | ● | |
| 01412010 | TESA YE | 5 | 5,4 | 0,01 | 0,5 | 0 ÷ 25 ÷ 50 | – | – | |
| 353 | COMPAC 353 | 5 | 5,4 | 0,01 | 0,5 | 0 ÷ 25 ÷ 50 | ● | – | |
| 353E | COMPAC 353E IP54 | 5 | 5,4 | 0,01 | 0,5 | 0 ÷ 25 ÷ 50 | ● | ● | IP54 |

Permissible limits of a metrological characteristic (MPE/MPL)

| | | |
|--|--|---------|
| | | 0,01 mm |
| | Deviation span | 12 µm |
| | Deviation span within partial measuring span 0,10 mm | 6 µm |
| | Total deviation span | 14 µm |
| | Repeatability limit | 3 µm |
| | Max. hysteresis | 3 µm |
| | Measuring force | = 1,4 N |
| | – IP54 model | = 2 N |

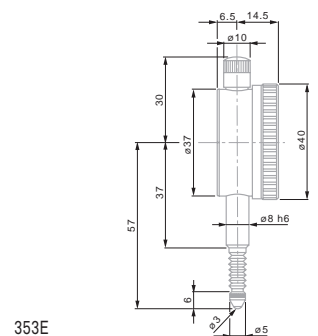
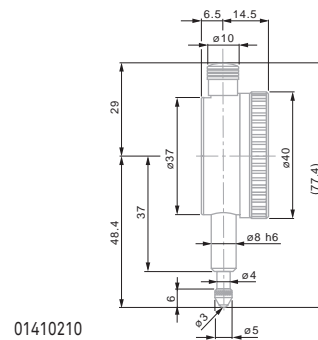

Dial Ø 57 and 58 mm – Reading 0,01 mm

Precision dial gauges



01410610



512K



532E



01416021

| No | = | | | | | | | |
|----------|----------------------------|-------|------|------|------|--------------|---|---|
| | | mm | mm | mm | mm | | | |
| 01410610 | TESA YR | 10 | 10,5 | 0,01 | 1 | 0 ÷ 50 ÷ 100 | ● | ● |
| 01410611 | TESA YR | 10 | 10,5 | 0,01 | 1 | 0 ÷ 50 ÷ 0 | ● | ● |
| 01412310 | TESA YE | 10 | 10,5 | 0,01 | 1 | 0 ÷ 50 ÷ 100 | - | - |
| 01416021 | MERCER 251-1 | 10 | 10,5 | 0,01 | 1 | 0 ÷ 50 ÷ 100 | - | ● |
| 512K | COMPAC 512K | 10 | 10,5 | 0,01 | 1 | 0 ÷ 50 ÷ 100 | - | - |
| 532 | COMPAC 532 | 10 | 10,5 | 0,01 | 1 | 0 ÷ 50 ÷ 100 | ● | - |
| 532E | COMPAC 532E IP54 | 10 | 10,5 | 0,01 | 1 | 0 ÷ 50 ÷ 100 | ● | - |
| 533S | COMPAC 533S limited travel | ± 0,5 | 4 | 0,01 | 1,27 | 50 ÷ 0 ÷ 50 | ● | - |

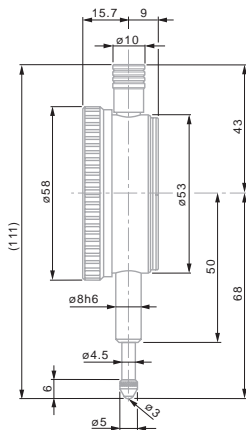

512K

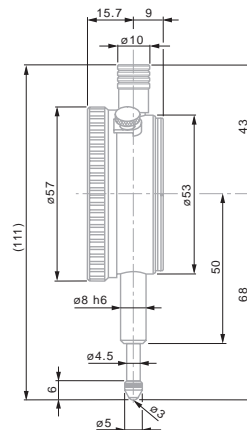

01410610 - 01410611

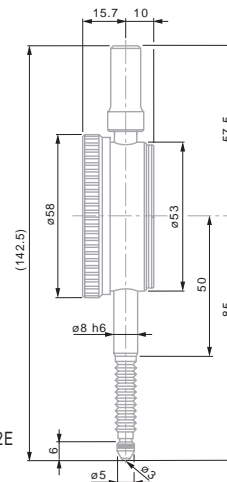

532E

Permissible limits of a metrological characteristic (MPE/MPL)

| | ± 0,5 | 10 mm |
|---|-------|---------|
| | 7 μm | 15 μm |
| Deviation span within the selected local measuring span 0.10 mm | 5 μm | 8 μm |
| Total deviation span | 9 μm | 17 μm |
| | 3 μm | 3 μm |
| | 3 μm | 3 μm |
| | = 1 N | ≤ 1,5 N |
| - Models IP54 | - | ≤ 2,2 N |



EN ISO 463
Factory standard



Rotating dial. With or without dial lock for standard models



0,01 mm



Full-metal dial casing. Mounting shank and plunger in hardened stainless steel



See table for tolerance limits



With or without anti-shock mechanism



Adjustable tolerance markers. Thread M2,5 for measuring insert



Measuring insert with Ø 3 mm ball tip already mounted



Cardboard box



Identification number



Inspection report with declaration of conformity



Dial Ø 58 mm – Reading 0,01 mm – Long travel

Long range precision dial gauges



EN ISO 463
Factory standard

Rotating dial. With
or without dial lock.

0,01 mm

Full-metal dial
casing. Mounting
shank and plunger
in hardened stain-
less steel

See table for
tolerance limits

Adjustable tolerance
markers. Thread
M2,5 for measuring
insert

Measuring insert
with 3 mm ball tip
already mounted

Cardboard box

Identification
number

Inspection report
with declaration of
conformity



712

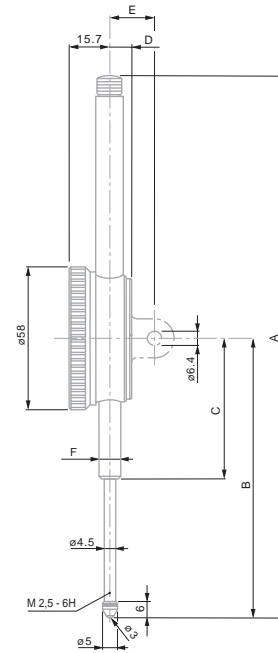

| No | = | | | | | | | | | |
|-----|------------|-----|-------|------|----|--------------|---|---|---|----|
| | | mm | mm | mm | mm | mm | | | | |
| 712 | COMPAC 712 | 30 | 30,5 | 0,01 | 1 | 0 ÷ 50 ÷ 100 | ● | – | – | 58 |
| 722 | COMPAC 722 | 50 | 50,5 | 0,01 | 1 | 0 ÷ 50 ÷ 100 | ● | – | – | 58 |
| 732 | COMPAC 732 | 100 | 100,5 | 0,01 | 1 | 0 ÷ 50 ÷ 100 | ● | – | – | 58 |

Dimensions

| mm | 30 mm | 50 mm | 100 mm |
|----|-------|-------|--------|
| A | 148 | 228 | 390 |
| B | 88 | 117,2 | 211,6 |
| C | 50 | 60 | 103,6 |
| D | 10 | 9 | 9 |
| E | 20 | 19 | 19 |
| F | Ø 8h6 | Ø 8h6 | Ø 8h6 |

Permissible limits of a metrological characteristic (MPE/MPL)

| | Deviation span | 20 µm | 25 µm | 30 µm |
|--|----------------------|---------|---------|---------|
| | Total deviation span | 25 µm | 30 µm | 35 µm |
| | Repeatability limit | 3 µm | 3 µm | 3 µm |
| | Max. hysteresis | 5 µm | 5 µm | 8 µm |
| | Measuring force | ≤ 2,2 N | ≤ 2,5 N | ≤ 3,2 N |



Dial Ø 82 mm – Reading 0,01 mm

Precision dial gauges



01410910

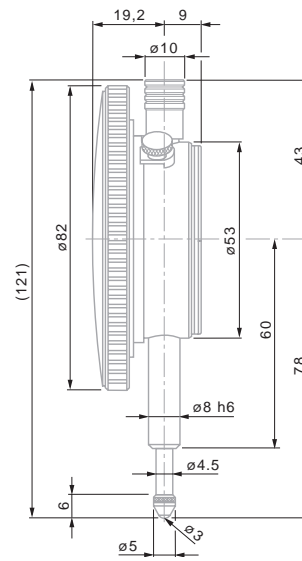

01410910



EN ISO 463
Factory Standard



Rotating dial. With
or without dial lock



0,01 mm



Full-metal dial ca-
sing. Stainless steel
fixing shank and
plunger, hardened



See table for
tolerance limits



High performance
shock-proof system
in the 2 directions



M2,5 thread for
measuring insert



Measuring insert
with Ø 3 mm ball tip,
already mounted



Cardboard box



Identification
number



Inspection report
with declaration of
conformity

| | | | | | | | |
|----------|----|------|------|-----|--------------|---|---|
| | | | | | | | |
| 01410910 | mm | mm | mm | mm | 0 ÷ 50 ÷ 100 | ● | ● |
| | 10 | 10,5 | 0,01 | 0,1 | | | |

Permissible limits of a metrological characteristic (MPE/MPL)

| | | |
|--|---|---------|
| | | 10 mm |
| | Deviation span | 15 µm |
| | Deviation span within partial measuring span of 0,10 mm | 8 µm |
| | Total deviation span | 17 µm |
| | Repeatability limit | 3 µm |
| | Max. hysteresis | 3 µm |
| | Measuring force | ≤ 1,4 N |

Dial Ø 40 mm – Reading 0,002 mm

Precision dial gauges



EN ISO 463
Factory standard

Rotating dial

0,002 mm

Full-metal casing.
Fixing shank and
plunger in hardened
stainless steel

See table for
tolerance limits

Adjustable tolerance
markers. Thread
M2,5 for measuring
insert

Measuring insert
with Ø 3 mm ball tip
already mounted

Cardboard box

Identification
number

Inspection report
with declaration
of conformity



355E



365S

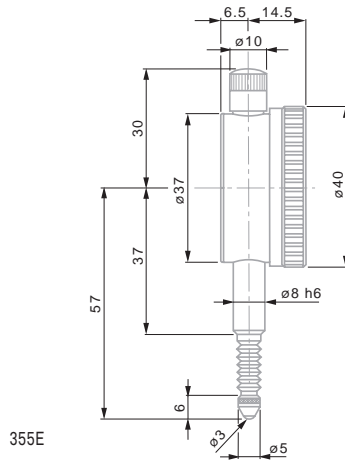

355E

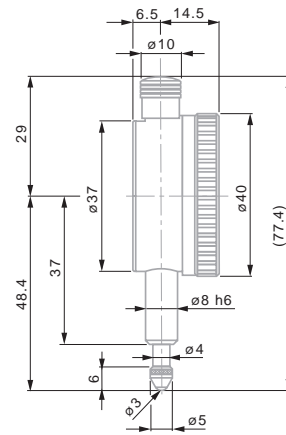

365S

| | mm | mm | mm | mm | | | | | |
|------|-------|-----|-------|-----|-------------|---|---|----|-------|
| 355 | 3 | 3,3 | 0,002 | 0,2 | 0 ÷ 10 ÷ 20 | ● | - | 40 | |
| 355E | 3 | 3,3 | 0,002 | 0,2 | 0 ÷ 10 ÷ 20 | ● | - | 40 | IP 54 |
| 365S | ±0,08 | 1,5 | 0,002 | 0,2 | 8 ÷ 0 ÷ 8 | ● | - | 40 | |

Permissible limits of a metrological characteristic (MPE/MPL)

| | ±0,08 mm | 3 mm |
|---|--------------|--------------------|
| Deviation span | 2 µm | 10 µm |
| Deviation span within the selected local measuring span 0,10 mm | 2 µm | 6 µm |
| Total deviation span | 4 µm | 12 µm |
| Repeatability limit | 1 µm | 1,5 µm |
| Max. hysteresis | 1 µm | 2 µm |
| Measuring force - Model IP54 | ≤ 1,4 N - | ≤ 1,4 N ≤ 1,7 N |



Dial Ø 58 mm – Reading 0,002 mm

Precision dial gauges

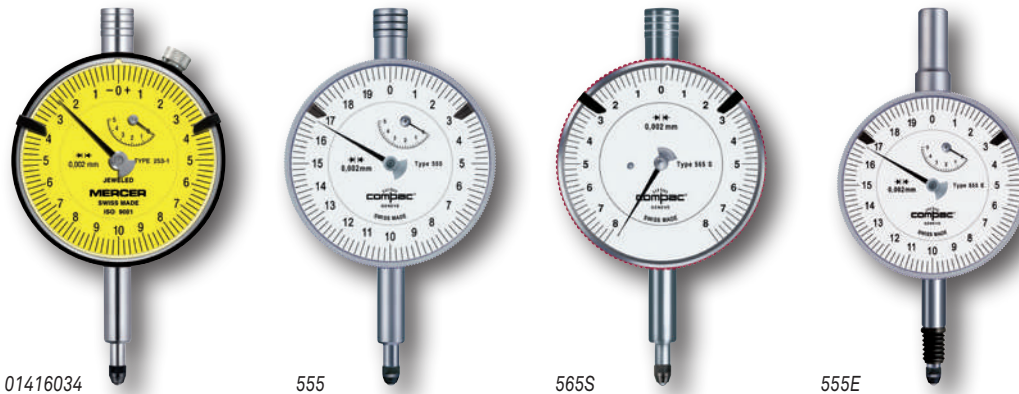

01416034

555

565S

555E

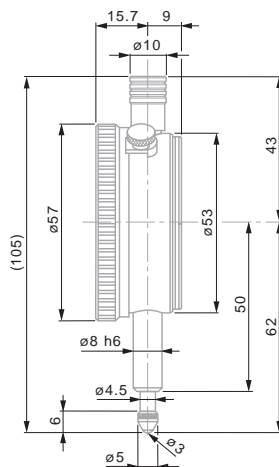

01416034

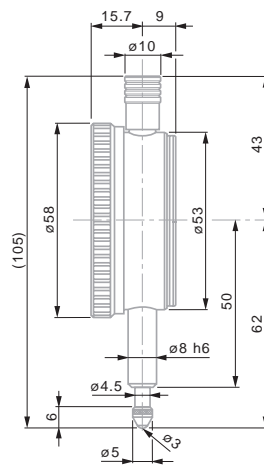

555

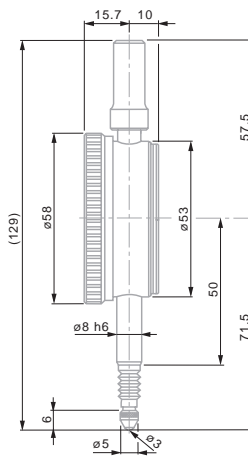

555E

- EN ISO 463 Factory standard
- Rotating dial. With or without dial lock.
- 0,002 mm
- Full-metal dial casing. Mounting shank and plunger in hardened stainless steel
- See table for tolerance limits
- Adjustable tolerance markers. Thread M2,5 for measuring insert
- Measuring insert with 3 mm ball tip already mounted
- Cardboard box
- Identification number
- Inspection report with declaration of conformity

| No | = | | | | | | | | | |
|----------|----------------------------|-------|-----|-------|-----|-------------|---|---|----|-------|
| | | mm | mm | mm | mm | | | | | |
| 01416034 | MERCER 253-1 | 5 | 5,3 | 0,002 | 0,2 | 0 ÷ 10 ÷ 0 | - | ● | 58 | - |
| 555 | COMPAC 555 | 5 | 5,3 | 0,002 | 0,2 | 0 ÷ 10 ÷ 20 | ● | - | 58 | - |
| 555E | COMPAC 555E IP54 | 5 | 5,3 | 0,002 | 0,2 | 0 ÷ 10 ÷ 20 | ● | - | 58 | IP 54 |
| 565S | COMPAC 565S limited travel | ±0,08 | 3,3 | 0,002 | 0,2 | 8 ÷ 0 ÷ 8 | ● | - | 58 | - |

Permissible limits of a metrological characteristic (MPE/MPL)

| | ±0,08 mm | 5 mm |
|---------------------------------|--------------|--------------------|
| Deviation span | 4 µm | 12 µm |
| Total deviation span | 4 µm | 14 µm |
| Repeatability limit | 1 µm | 2 µm |
| Max. hysteresis | 1 µm | 2 µm |
| Measuring force - Model IP54 | ≤ 1,5 N - | ≤ 1,5 N ≤ 1,7 N |

Dial Ø 40 mm – Reading 0,001 mm

Precision dial gauges



N EN ISO 463
Factory standard

Cardboard box

0,001 mm

Full-metal dial casing. Mounting shank and plunger in hardened stainless steel

See table for tolerance limits

With shock-proof mechanism, in both directions

Adjustable tolerance markers. Thread M2,5 for measuring insert

Measuring insert with 3 mm steel ball tip already mounted

Cardboard box

No Identification number

Inspection report with declaration of conformity



01410010



01410120

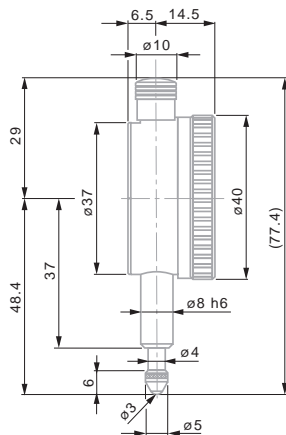

01410010

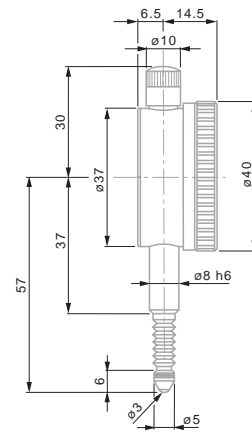

01410120

| No | = | | | | | | | | | | |
|----------|------------------|----|-----|-------|-----|----|--------------|---|---|----|-------|
| | | mm | mm | mm | mm | mm | | | | | |
| 01410010 | TESA YR | 1 | 1,5 | 0,001 | 0,1 | 40 | 0 ÷ 50 ÷ 100 | ● | ● | 40 | – |
| 01412510 | TESA YE | 1 | 1,5 | 0,001 | 0,1 | 40 | 0 ÷ 50 ÷ 100 | ● | – | 40 | – |
| 01410120 | TESA YR IP54 | 1 | 1,5 | 0,001 | 0,1 | 40 | 0 ÷ 50 ÷ 100 | ● | – | 40 | IP 54 |
| 367 | COMPAC 367 | 1 | 1,5 | 0,001 | 0,1 | 40 | 0 ÷ 5 ÷ 10 | ● | – | 40 | – |
| 367E | COMPAC 367E IP54 | 1 | 1,5 | 0,001 | 0,1 | 40 | 0 ÷ 5 ÷ 10 | ● | – | 40 | IP 54 |

Permissible limits of a metrological characteristic (MPE/MPL)

| | 1 mm |
|---|------------------|
| Deviation span | 4 µm |
| Deviation span within the selected local measuring span 0,10 mm | 4 µm |
| Total deviation span | 5 µm |
| Repeatability limit | 1 µm |
| Max. hysteresis | 1 µm |
| Measuring force – Model IP54 | ≤ 1,7 N ≤ 2 N |



Dial Ø 58 mm – Reading 0,001 mm

Precision dial gauges



01412511



556



01412611

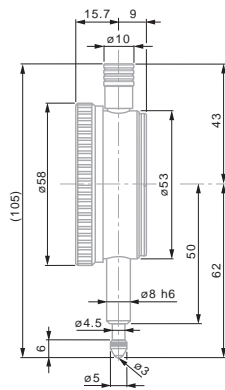

567

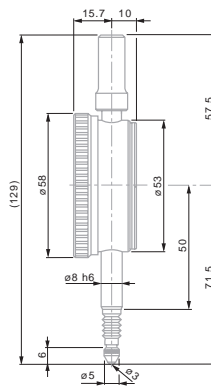

556E

- EN ISO 463
Factory standard
- 0,001 mm
- Full-metal dial casing. Mounting shank and plunger in hardened stainless steel
- See table for tolerance limits
- Effective anti-shock in the 2 directions
- Adjustable tolerance markers. Thread M2,5 for measuring insert
- Measuring insert with 3 mm Ø ball tip, already mounted
- Cardboard box
- Identification number
- Inspection report with declaration of conformity

| No | TESA | mm | mm | mm | mm | mm | mm | mm | mm | mm | mm |
|----------|------------------|----|-----|-------|-----|----|---------------|----|----|----|------|
| 01412511 | TESA YE | 1 | 1,5 | 0,001 | 0,1 | 58 | 0 ÷ 50 ÷ 100 | ● | - | | |
| 01412611 | TESA YE | 5 | 5,3 | 0,001 | 0,2 | 58 | 0 ÷ 100 ÷ 200 | ● | - | | |
| 556 | COMPAC 556 | 5 | 5,3 | 0,001 | 0,2 | 58 | 0 ÷ 10 ÷ 20 | ● | - | | |
| 567 | COMPAC 567 | 1 | 3,3 | 0,001 | 0,1 | 58 | 0 ÷ 5 ÷ 10 | ● | - | | |
| 556E | COMPAC 556E IP54 | 5 | 5,3 | 0,001 | 0,2 | 58 | 0 ÷ 10 ÷ 20 | ● | - | | IP54 |
| 01412711 | TESA YE IP54 | 1 | 1,5 | 0,001 | 0,1 | 58 | 0 ÷ 50 ÷ 100 | ● | - | | IP54 |
| 01410520 | TESA YR IP54 | 1 | 3,3 | 0,001 | 0,1 | 58 | 0 ÷ 50 ÷ 100 | ● | - | | IP54 |

Permissible limits of a metrological characteristic (MPE/MPL)

| | 1 mm | 5 mm |
|---|---------|---------|
| Deviation span | 4 µm | 12 µm |
| Deviation span within the selected local measuring span 0,10 mm | 4 µm | - |
| Total deviation span | 5 µm | 14 µm |
| Repeatability limit | 1 µm | 2 µm |
| Max. hysteresis | 1 µm | 2 µm |
| Measuring force | ≤ 1,7 N | ≤ 1,5 N |
| - Models IP54 | - | ≤ 1,7 N |

Dial Ø 82 mm – Reading 0,001 mm

Precision dial gauges



N EN ISO 463
Factory standard

Rotating dial. With or without dial lock.

0,001 mm

Full-metal dial casing. Stainless steel fixing shank and plunger, hardened

See table for tolerance limits

High performance anti-shock system in both directions

M2,5 thread for measuring inserts

Measuring insert with Ø 3 mm ball tip, already mounted

Cardboard box

No Identification number

Inspection report with a declaration of conformity

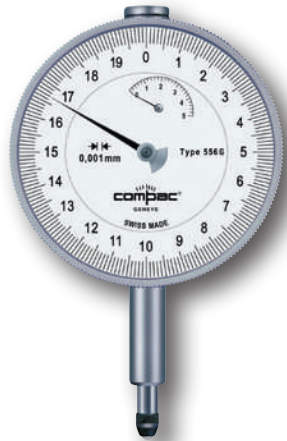

556G



01410810

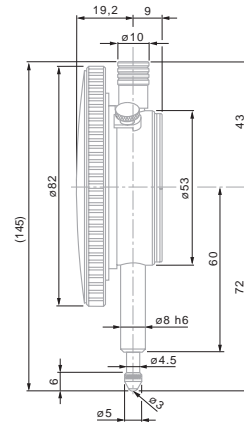

01410810

| | | | mm | mm | mm | mm | | | |
|----------|-------------|---|-----|-------|-----|--------------|---|---|----|
| 01410810 | TESA YR | 1 | 3,3 | 0,001 | 0,1 | 0 ÷ 50 ÷ 100 | ● | ● | 82 |
| 556G | COMPAC 556G | 5 | 5,3 | 0,001 | 0,2 | 0 ÷ 10 ÷ 20 | ● | - | 82 |

Permissible limits in a metrological characteristic (MPE/MPL)

| | 1 mm | 5 mm |
|---|---------|---------|
| Deviation span | 4 µm | 12 µm |
| Deviation span within partial measuring span of 0,10 mm | 4 µm | - |
| Total deviation span | 5 µm | 14 µm |
| Repeatability limit | 1 µm | 2 µm |
| Max. hysteresis | 1 µm | 2 µm |
| Measuring force | ≤ 1,7 N | ≤ 1,5 N |



STANDARD DIAL GAUGES

The Standard product line offers a range of heavy duty and competitively priced dial gauges.

Dial Ø 40 / 58 – Reading 0,1 mm

Precision dial gauges

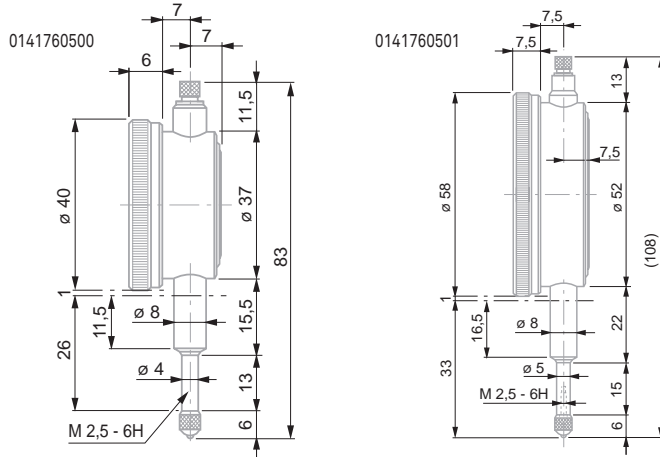

0141760500
0141760501

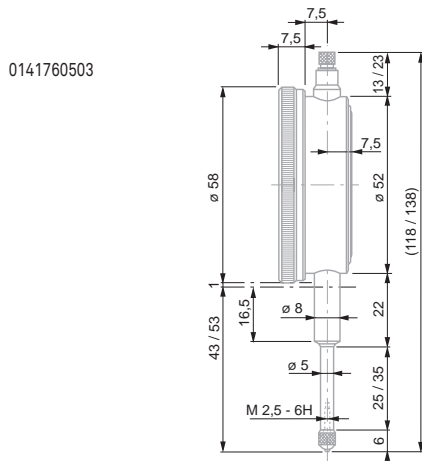

0141760503



- EN ISO 463
Factory standard
- Rotating dial
- 0,1 mm
- Full-metal casing.
Mounting shank and plunger in hardened stainless steel
- See table for tolerance limits
- Without anti-shock mechanism
- Thread M2,5 for measuring insert
- Measuring insert with 3,175 mm Ø ball tip already mounted
- Plastic case
- Identification number
- Declaration of conformity

| 0141760500 | 10 | 10,5 | 0,1 | 10 | 0 ÷ 5 ÷ 10 | - | ≤ 1,0 |
|------------|----|------|-----|----|------------|---|-------|
| 0141760501 | 10 | 10,5 | 0,1 | 10 | 0 ÷ 5 ÷ 10 | - | ≤ 1,0 |
| 0141760503 | 30 | 30,5 | 0,1 | 10 | 0 ÷ 5 ÷ 10 | - | ≤ 1,5 |

Permissible limits of a metrological characteristic (MPE/MPL)

| | | |
|--|--|-------|
| | | 10 mm |
| | Deviation span | 40 µm |
| | Deviation span within partial measuring span of 0.1 mm | 25 µm |
| | Total deviation error | 55 µm |
| | Repeatability limit | 15 µm |
| | Max. hysteresis | 15 µm |

Dial Ø 58 mm – Reading 0,01 mm – Standard and long travel

Precision dial gauges

Standard and long travel models

- EN ISO 463 Factory standard
- Rotating dial
- 0,01 mm
- Full-metal casing. Mounting shank and plunger in hardened stainless steel
- See reference table
- With or without anti-shock mechanism
- Adjustable tolerance markers. Thread M2,5 for measuring insert
- Measuring insert with Ø 3,175 mm steel ball tip, already mounted
- Plastic case or cardboard box
- Identification number
- Declaration of conformity



01419048

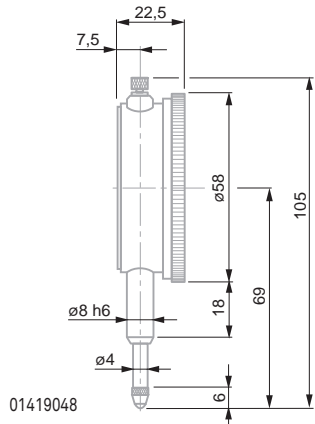

01419048

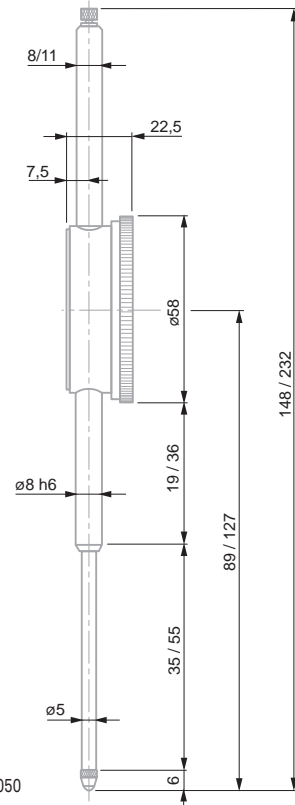

01419050

| | mm | mm | mm | | | N | |
|----------|----|------|----|--------------|---|---------|----|
| 01419048 | 10 | 0,01 | 1 | 0 ÷ 50 ÷ 100 | – | ≈1 | 58 |
| 01419050 | 50 | 0,01 | 1 | 0 ÷ 50 ÷ 100 | ● | 1,5 ÷ 2 | 58 |

For magnetic or central lug backs, see backs for ROCH and ETALON dial gauges

Permissible limits for a metrological characteristic (MPE/MPL)

| | | | |
|--|---|----|-------|
| | mm | 10 | 50 |
| | Deviation span | µm | 15 25 |
| | Deviation span within selected partial measuring span 0,10 mm | µm | 8 12 |
| | Repeatability Limit | µm | 3 3 |



DIAL GAUGES – ANALOGUE WITH BACK MOUNTED PLUNGER

Mechanical dial gauges with back mounted plungers differentiate by their concept of presenting a display which is perpendicular to the movement of the measuring stem.

Dial Ø 40 mm – Reading 0,01 or 0,002 mm



CP352S



CP353



CP355

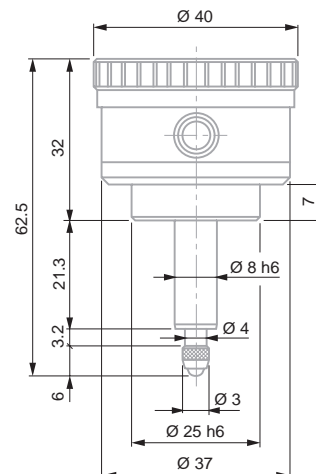

CP353



EN ISO 463
Factory standard



Rotating dial



Full-metal casing.
Mounting shank and
plunger in hardened
stainless steel



See reference table



With anti-shock
mechanism



Adjustable tolerance
markers. Thread
M2,5 for measuring
insert. Fastening
with sleeve Ø 8h6
and 25h6



Measuring insert
with Ø 3 mm steel
ball tip, already
mounted



Cardboard box



Identification
diameter



Inspection report
with declaration of
conformity

| No | = | | | | | | | | | |
|---------|--------------------------------------|-------|-----|-------|----|-----|-----|-----|-------------|-----|
| | | mm | mm | mm | µm | µm | µm | mm | | N |
| CP 353 | COMPAC CP353 | 3 | 3,2 | 0,01 | 14 | 3 | 3 | 0,5 | 0 ÷ 25 ÷ 50 | 0,9 |
| CP 355 | COMPAC CP355 | 3 | 3,2 | 0,002 | 14 | 2,2 | 2,5 | 0,2 | 0 ÷ 10 ÷ 20 | 0,9 |
| CP 352S | COMPAC CP352S with limited travel | ± 0,4 | 3,2 | 0,01 | 9 | 3 | 3 | (1) | 40 ÷ 0 ÷ 40 | 0,9 |

S: Limited range of indication, restricted reading.
The needle makes less than one revolution of the dial, all reading errors due to revolution counter are eliminated.

INSERTS FOR DIAL GAUGES, AXIAL PROBES, ETC. - EXECUTION WITH M2,5 THREAD

Spherical measuring inserts, standard.

| | |
|----------|----------|
| No | |
| 03510001 | Steel |
| 03510002 | Carbide |
| 03560001 | Sapphire |

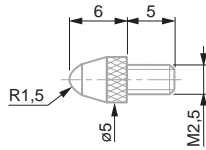

Spherical measuring insert, short

| | |
|----------|---------|
| No | |
| 03560007 | Carbide |

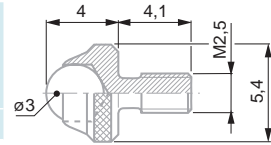

Spherical measuring inserts, long

| | |
|----------|---------|
| No | |
| 03560019 | Steel |
| 03560020 | Carbide |
| 03560021 | Ruby |

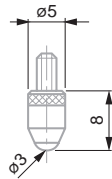

Spherical measuring inserts, R = 0,5 mm.

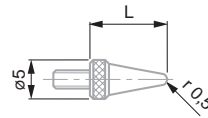

| | | | |
|----------|-------|--|------|
| No | | | L mm |
| 03560035 | Steel | | 5 |
| 03560036 | Steel | | 10 |
| 03560037 | Steel | | 15 |
| 03560038 | Steel | | 20 |
| 03560039 | Steel | | 30 |
| 03560040 | Steel | | 40 |

Spherical measuring inserts

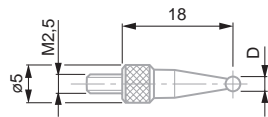

| | | | |
|----------|---------|--|-------|
| No | | | D, mm |
| 03560051 | Carbide | | 1 |
| 03560052 | Carbide | | 2 |
| 03560053 | Carbide | | 3 |
| 03560054 | Carbide | | 4 |
| 03560055 | Carbide | | 5 |
| 03560056 | Carbide | | 6 |
| 03560057 | Carbide | | 7 |
| 03560058 | Carbide | | 8 |

Spherical measuring insert with 4 interchangeable pins, R = 1,5 mm

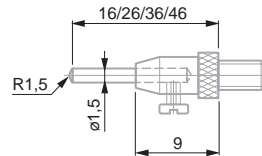

| | | | |
|----------|-------|--|----------------|
| No | | | L, mm |
| 03510201 | Steel | | 16, 26, 36, 46 |

Spherical measuring inserts

| | |
|----------|---------|
| No | |
| 03510101 | Steel |
| 03510102 | Carbide |

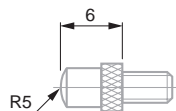

Spherical measuring inserts

| | |
|----------|---------|
| No | |
| 03560017 | Steel |
| 03560018 | Carbide |

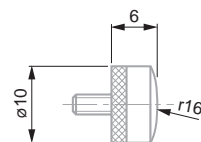

Measuring insert with offset (A)
Pointed measuring face
Lock nut for radial alignment.

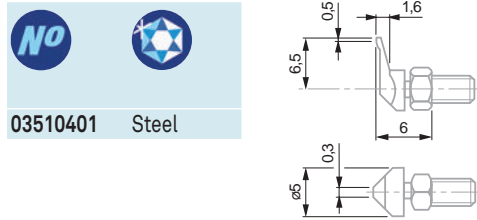

03510401 Steel

Measuring insert with offset (A)
Pointed measuring face
Lock nut for radial alignment.

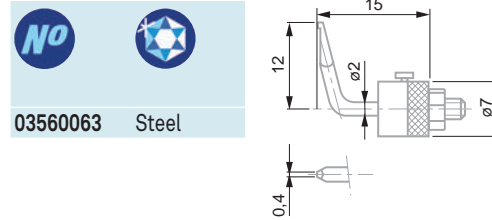

03560063 Steel

Measuring insert with needle contact point



03560030 Steel

Measuring inserts with ball-bearing rollers
Lock nut for radial alignment

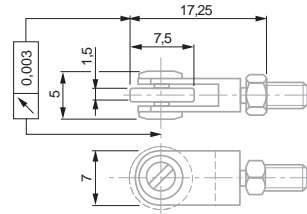

| No | Shape | |
|----------|-------------|-------|
| 03560010 | Cylindrical | Steel |
| 03560011 | Domed | Steel |

Inserts with a knife blade measuring face
Lock nut for radial alignment

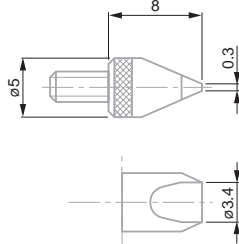

| No | | B, mm |
|----------|-------|-------|
| 03560024 | Steel | 0,3 |
| 03560025 | Steel | 0,3 |

Inserts with a knife blade steel face
Lock nut for radial alignment

| No | L, mm |
|----------|-------|
| 03560031 | 5 |
| 03560032 | 10 |
| 03560033 | 15 |
| 03560034 | 20 |

Insert with a cylindrical measuring face
Lock nut for radial alignment

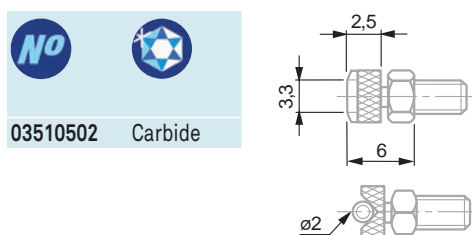

03510502 Carbide

Insert with a narrow, off-centre measuring face
Lock nut for radial alignment

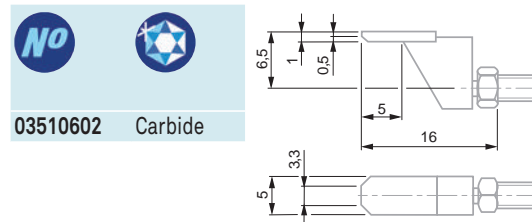

03510602 Carbide

Insert with a narrow measuring face
Parallelism adjustable
Lock nut for radial alignment



03510702 Carbide

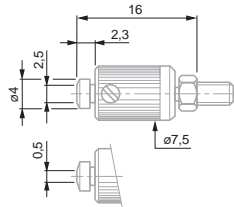

Inserts with a flat measuring face.

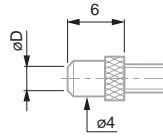

| No | Length | Material |
|----------|--------|----------|
| 03510801 | 2,5 | Steel |
| 03510802 | 2,5 | Carbide |
| 03560022 | 3,4 | Steel |
| 03560023 | 3,4 | Carbide |

Insert with a flat measuring face
Parallelism adjustable
Counter-nut for radial alignment



03510902 Métal dur

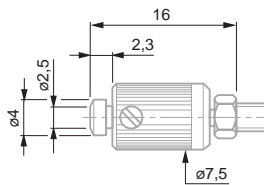

Inserts with a flat measuring face, in steel

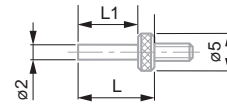

| No | L, mm | L1, mm |
|----------|-------|--------|
| 03560026 | 5 | 2,8 |
| 03560027 | 10 | 7,8 |
| 03560028 | 15 | 12,8 |
| 03560029 | 20 | 17,8 |

Inserts with interchangeable pins
Flat measuring face



03560008 Steel
03560009 Carbide

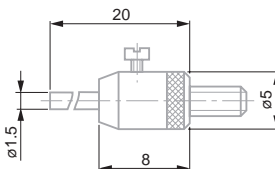

Inserts with flat measuring face

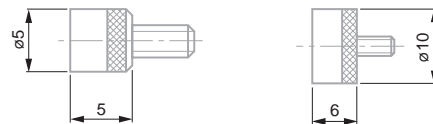

| No | Length | Material |
|----------|--------|----------|
| 03560012 | 5 | Steel |
| 03560013 | 5 | Carbide |
| 03560014 | 10 | Steel |
| 03560015 | 10 | Carbide |
| 03560016 | 20 | Steel |

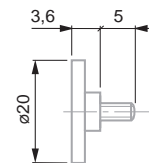

Connectors for measuring inserts

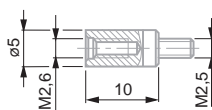

| No | Outside | Inside |
|----------|---------|--------|
| 03560092 | M2,5 | M2 |
| 03560065 | M3 | M2,5 |

Extensions for measuring inserts

| No | L, mm |
|----------|-------|
| 03560042 | 10 |
| 03560043 | 15 |
| 03560044 | 20 |
| 03560045 | 25 |
| 03560046 | 30 |
| 03560047 | 35 |
| 03560048 | 40 |
| 03560049 | 45 |
| 03560050 | 50 |

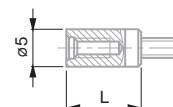

Extensions for measuring inserts.

| No | L, mm |
|----------|-------|
| 03540501 | 10 |
| 03540502 | 15 |
| 03540503 | 20 |
| 03540504 | 40 |

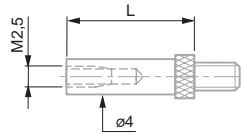

- EXECUTIONS WITH A M2 COUPLING THREAD



Spherical measuring inserts, M2 thread

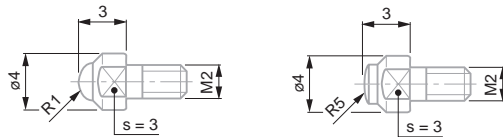

| No | mm | |
|----------|-----|---------|
| 03510204 | R 1 | Carbide |
| 03510103 | R 5 | Carbide |

Spherical measuring inserts, R = 5 mm, M2 thread

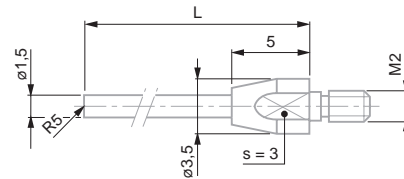

| No | | L, mm |
|----------|---------|-------|
| 03510202 | Carbide | 16 |
| 03510203 | Carbide | 26 |

Measuring insert with cylindrical measuring face. Lock nut for radial alignment, M2 thread

| No | Carbide |
|----------|---------|
| 03510503 | |

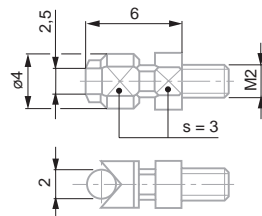

Extensions for measuring inserts, M2

| No | L, mm |
|----------|-------|
| 03540505 | 10 |
| 03540506 | 15 |

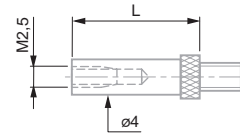

ADDITIONAL ACCESSORIES FOR DIAL GAUGES



Device for plunger retraction for mounting on the bottom stem

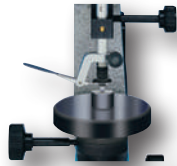

No



Consisting of:

03540104 - 03540101: Lever
- 03540102: Washer

Device for plunger retraction for mounting on the top stem

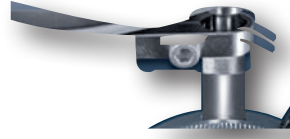

No



mm

03560004 Ø 40
03560005 Ø 58



Retraction lever Bottom mounted lift lever

No



01960005 Bottom mounted lift lever
Contains only lifting lever



90° angle probe. For the transmission of movements of the measuring plunger. Max. travel up to 10 mm. For dial gauges of 0,01 mm

No



03560006 90° angular probe
03560012; Insert with flat measuring face, Ø 5 mm



Magnetic force = 150 N

A Matt chrome plated except for tinted model numbers 01460010, 01460011

Backs for ROCH and ETALON Dial Gauges

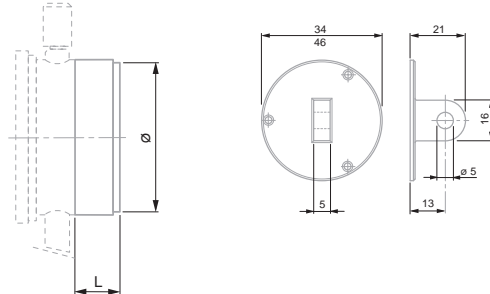

No



Bezel diameter, mm



Back, mm



01462004 40 34 Back with central lug
01462005 58, 60, 80 46 Back with central lug

Backs for dial gauges TESA YR – YE / MERCER / COMPAC / DIGICO 200-700 – Ø 40 mm dial models

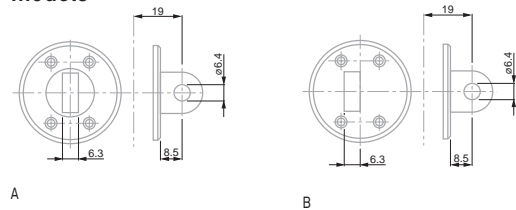

No



01460008 A – back with centre lug
01460009 B – Back with offset lug



Magnetic holding force = 150 N

A Dull chrome-plated except for model numbers 01460016, 01460017.

Backs for dial gauges TESA YR – YE / MERCER / COMPAC / DIGICO 200-700 – Ø 58 and 82mm dial models

No



01460014 C
01460015 D

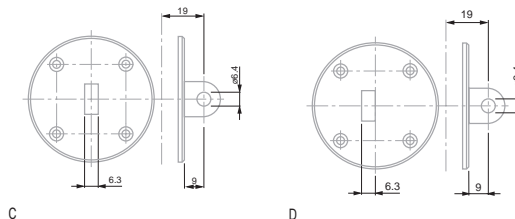

C

D





Lever-type Dial Test Indicators



TESA IP65 Electronic Dial Test Indicators

Provides the advantages of a mechanical test indicator with a digital reading.



- Inductive patented measuring system.
- Analogue and digital indication.
- Digital step of 0,01/0,001 mm.
- Selectable scale division: 10, 20, 50 μ m/1, 2, 5 μ m.
- Cutting oils and liquid coolant resistant (IP65).
- Metric/inch conversion.
- RS232 data output combined with external power supply.
- Displayed measuring modes (NOR/MIN/MAX/MAX-MIN).
- Automatic shut-down.
- Compatible with all TESAST accessories.

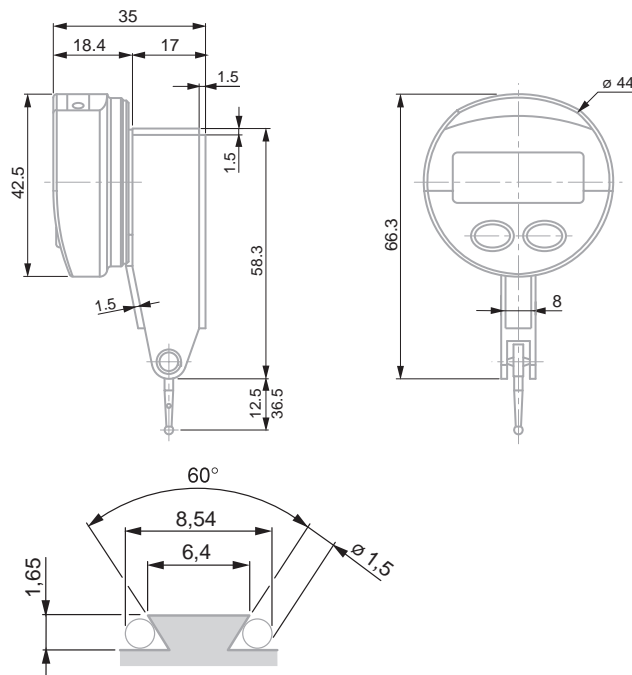

| No | | | | | |
|----------|-----|------------|----------------|-----------------|-----------------|
| | mm | mm | in | N (\pm 15 %) | Stem length, mm |
| 01830001 | 0,8 | 0,01/0,001 | 0.0005/0.00005 | 0,13 | 12,5 |
| 01830002 | 0,5 | 0,01/0,001 | 0.0005/0.00005 | 0,07 | 36,5 |

OPTIONAL ACCESSORIES:

- 01961000 Lithium battery, 3V, CR2032
 - 04761060 RS 232 cable with external power supply
- Compatible with all TESAST measuring inserts and accessories

- LCD, 5 digits + unit
- Resolution to 0,01/0,001 mm; 0.0005/0.00005 in
- Display digit height 6 mm
- Max. perm. errors: $f_e = 10 \mu$ m; $f_{ges} = 13 \mu$ m; Pre-span = 0,05 mm
- Repeatability: $f_w = 1 \mu$ m
- Hysteresis: $f_h = 3 \mu$ m
- L = 12,5 mm; max. 0,05 m/s; L = 36,5 mm; max. 0,15 m/s
- Number of measurements per second: 9
- Zero-setting
- RS232
- 3 V lithium battery, type CR2032
- Battery life > 4000 hours
- Operating temperature range: +5°C to +40°C
- Degree of protection: IP65 (IEC 529)
- EN 61326-1
- 73 g (L = 12,5 mm); 75 g (L = 36,5 mm)
- Supplied in a plastic case with:
1 Insert with a 2 mm dia. (No. 01860202)
1 Wrench (No. 01860307)
1 Mounting rod 8 mm dia. (No. 01840105)
- Identification number
- Declaration of conformity



DIN 2270
NFE 11-053

TESATAST DIAL TEST INDICATORS

These lever-type dial test indicators are especially intended for use on the shop floor or in the inspection room – Ideally suited for comparative measurements on a surface plate, for instance – Determine form, shape and position deviations as well as axial and runout errors.

- Bidirectional measuring with automatic reversal inside the movement.
- Continuous clockwise pointer rotation providing error-free reading.
- Insensitive to magnetic fields.
- Jewelled movement with 7 rubies.
- Ball-bearing lever system. Measuring insert swivelling through to 240°.
- Very low measuring force.
- Exceptionally robust with full-metal construction.

Standard model

Well proven over thousands of times. The dial face is parallel to the axis of the measuring insert.

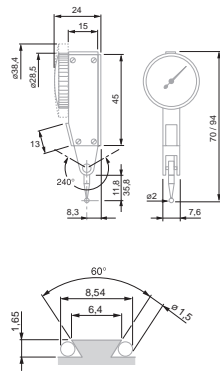

Perpendicular model

Lever test indicator with dial face mounted at right angle to the axis of the measuring insert.

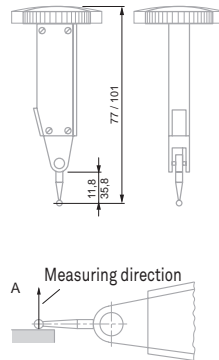

Lateral Model

Dial test indicator with dial face mounted parallel to the axis of the measuring insert but on the flat side of the dial housing.

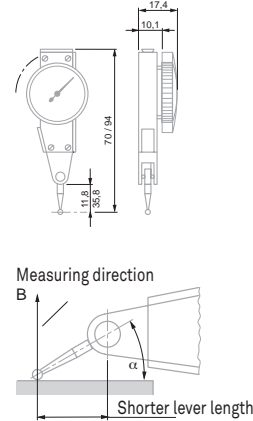

Note on the use of TESATAST dial test indicators

With the measuring insert lying parallel to the workpiece surface (Fig. A), these indicators give true reading due to the amplification factor to 1:1.

In another measuring position (angle α in Fig. B), the effective lever length changes so that the read value needs to be corrected. With respect to this, also refer to the instruction manual.

Permissible limits of a metrological characteristic (MPE/MPL)

| | | 0,02 mm | 0,01 mm | 0,002 mm |
|---|---------|------------------|------------------|-------------------|
| Deviation span, f_e | | 27 μm | 10 μm | 2 μm |
| Deviation span within the local measuring span, f_t | 0,20 mm | 12 μm | | |
| | 0,10 mm | | 5 μm | |
| | 0,02 mm | | | 1 μm |
| Total deviation span, f_{ges} | | 31 μm | 13 μm | 3,5 μm |
| Repeatability limit, f_w | | 4 μm | 3 μm | 1 μm |
| Max. hysteresis, f_u | | 4 μm | 3 μm | 1,5 μm |
| Measuring force with insert: | Length | 12,53 mm | 0,15 N | 0,15 N |
| | | 36,53 mm | 0,06 N | 0,06 N |





TESATAST Standard Models

| No | | | | | | |
|-----------|-----|-------|----|--------------|--|-------|
| 01810005 | 0,8 | 0,01 | 28 | 0 ÷ 0,4 ÷ 0 | | 12,53 |
| 01810006 | 0,8 | 0,01 | 38 | 0 ÷ 0,4 ÷ 0 | | 12,53 |
| 01810007 | 0,5 | 0,01 | 28 | 0 ÷ 0,25 ÷ 0 | | 36,53 |
| 01810008 | 0,5 | 0,01 | 38 | 0 ÷ 0,25 ÷ 0 | | 36,53 |
| 01810009 | 0,2 | 0,002 | 28 | 0 ÷ 100 ÷ 0 | | 12,53 |
| 01810010 | 0,2 | 0,002 | 38 | 0 ÷ 100 ÷ 0 | | 12,53 |
| S18001695 | 0,2 | 0,001 | 38 | 0 ÷ 100 ÷ 0 | | 12,53 |



SWISSTAST Standard Models

| No | | | | | | |
|----------|-----|-------|----|-------------|--|-------|
| 01811000 | 0,8 | 0,01 | 28 | 0 ÷ 0,4 ÷ 0 | | 12,53 |
| 01811001 | 0,2 | 0,002 | 38 | 0 ÷ 100 ÷ 0 | | 12,53 |

Same technical data as standard models, but equipped with a 2 mm dia. ruby ball tip No. 01860302.



TESATAST Perpendicular Models

| No | | | | | | |
|----------|-----|-------|----|--------------|--|-------|
| 01810204 | 0,8 | 0,01 | 28 | 0 ÷ 0,4 ÷ 0 | | 12,53 |
| 01810205 | 0,5 | 0,01 | 28 | 0 ÷ 0,25 ÷ 0 | | 36,53 |
| 01810304 | 0,2 | 0,002 | 38 | 0 ÷ 100 ÷ 0 | | 12,53 |

- DIN 2270
NF E 11-053
- Rotating dial
- Very low measuring force, see table.
- Movement with patented shock proof system
- Lever system with friction drive to prevent overload
- Accuracy: see table.
- Supplied in a plastic case together with:
1 Insert with a 2 mm dia.
1 Wrench (No. 01860307)
1 Mounting rod 8 mm dia. (No. 01840105)
- Identification number
- Declaration of conformity

TESATAST Lateral Models



| No | | | | | |
|----------|-----|-------|-------|-------------|------------|
| | mm | mm | ∅, mm | | Insert, mm |
| 01810011 | 0,8 | 0,01 | 28 | 0 ÷ 0.4 ÷ 0 | 12,53 |
| 01810012 | 2 | 0,02 | 38 | 0 ÷ 1.0 ÷ 0 | 36,53 |
| 01810013 | 0,2 | 0,002 | 28 | 0 ÷ 100 ÷ 0 | 12,53 |

TESATAST Measuring Inserts

| No | | | |
|----------|--------------------|-------------------|-------|
| | Ball tip, mm | Ball tip material | mm |
| 01860201 | 1 | Carbide | 12,53 |
| 01860202 | 2 | Carbide | 12,53 |
| 01860203 | 3 | Carbide | 12,53 |
| 01860211 | 1 | Carbide | 36,53 |
| 01860212 | 2 | Carbide | 36,53 |
| 01860213 | 3 | Carbide | 36,53 |
| 01860301 | 1 | Ruby | 12,53 |
| 01860302 | 2 | Ruby | 12,53 |
| 01860303 | 3 | Ruby | 12,53 |
| 01860304 | 1 | Ruby | 36,53 |
| 01860305 | 2 | Ruby | 36,53 |
| 01860307 | Wrench for inserts | | |

Note:

The original measuring insert mounted on every TESATAST as well as any other insert of the same nominal length but with a different ball tip diameter are fully interchangeable.

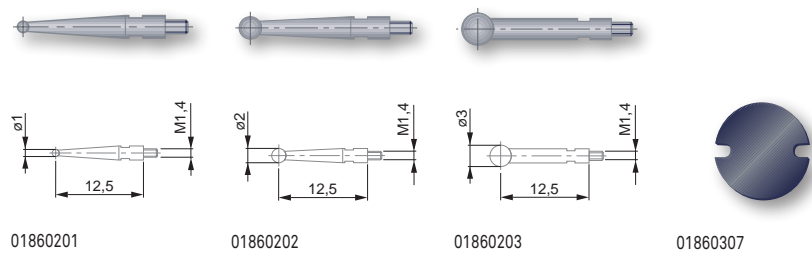

M1,4 coupling thread

Ball tip made of carbide or ruby



DIN 2270
NFE 11-053

Technical data: see description for each product

Plastic case

Identification number

Declaration of conformity

Indicator Sets with Small Support

| No | |
|---------------------------------|---|
| 01630003 | Indicator set with small support |
| COMPOSITION OF THE SETS: | |
| 01810005 | TESATAST standard model |
| 01810010 | TESATAST standard model |
| 01860203 | Carbide measuring insert |
| 01840104 | Mounting rod |
| 01840105 | Mounting rod |
| 01860307 | Wrench for inserts |
| 01639007 | Magnetic support INTERAPID UJ15, dovetail clamp and ∅ 8 mm cylindrical clamping |





Accessories for TESATAST

Clamp

| No | = | | mm |
|----------|---|--|---------------|
| 01860401 | | | Ø 5,6 / Ø 9,5 |



01860401

Mounting Rods

| No | = | | mm |
|----------|---|--|-----------------------------------|
| 01840404 | | | Ø 8 x 25 |
| 01840405 | | | Ø 8 x 90 |
| 01840406 | | | Ø 8 x 25 (Ø 8 for clamping bore) |
| 01840501 | | | Ø 8 x 25 (Ø 4 for clamping point) |
| 01840407 | | | Ø 8 x 125 |



01840501



01840404



01840405



01840406



01840407

Fixing Shank

| No | = | | mm |
|----------|---|--|--------------------------------|
| 01840104 | | | Ø 4 |
| 01840105 | | | Ø 8 |
| 01840202 | | | Ø 8 x 80 (Ø 5,6 for the tenon) |
| 01860008 | | | Ø 6 |

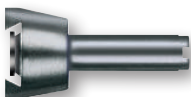

01840104



01840105



01840202

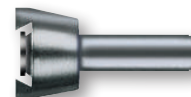

01860008



INTERAPID 312 LEVER DIAL TEST INDICATORS

INTERAPID 312 Dial Test Indicators very large measuring span – Ideal for inspecting all significant size variations, e.g. on the surface plate – Measures position, form and shape errors.



- Safe reading thanks to secondary pointer totalling the number of revolutions made by the main pointer.
- Bidirectional measuring with automatic reversal within the movement.
- Pointer rotation direction is always constant due to automatic reversal effect.
- Jewelled movement with rubies.
- Ball-bearing lever system. Measuring insert swivelling through 210°.
- Particularly robust due to full-metal construction.
- Monobloc housing with mounting through dovetail clamping and a Ø 4 mm swivelling shank.

Stylus insert with angular position of 12°

All models INTERAPID 312 are designed to give a true reading when the angle between the stylus and the workpiece surface is 12° (Fig. A). In any other measuring position, including parallel position of the stylus against the workpiece surface, measured readings have to be corrected accordingly (Fig. B). Please consult the instruction manual on this subject.

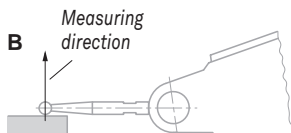
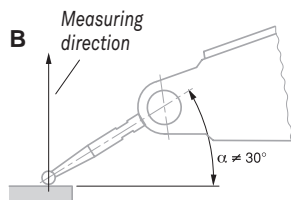
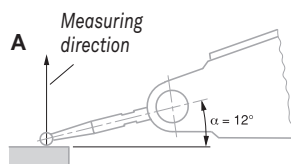

Standard Model

Time-tested dial test indicator. The dial face is mounted parallel to the axis of the insert.

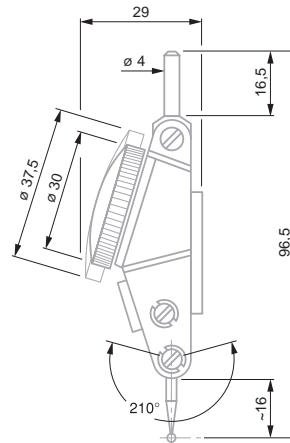

Perpendicular model

Dial test indicator with dial face mounted at right angle to the axis of the insert.

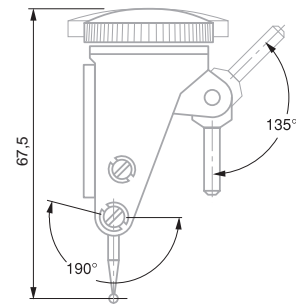

Permissible limits of a metrological characteristic (MPE/MPL)

| | 0,01 mm | | 0,002 mm | |
|---|--------------------|------------|--------------------|-----------|
| | Pointer revolution | | Pointer revolution | |
| Deviation range over partial measuring range, f_e | 1 | 2 | 1 | 2 |
| Total deviation range, f_{ges} | 10 μ m | 20 μ m | 4 μ m | 8 μ m |
| Repeatability limit, f_w | 3 μ m | | 1 μ m | |
| Max. hysteresis, f_u | 3 μ m | | 2 μ m | |
| Measuring force | 0,12 N | | 0,25 N | |





INTERRAPID 312 Standard Models

| No | mm | mm | ∅, mm | | Insert, mm |
|-----------|-----|-------|-------|------------|------------|
| 074111366 | 1,6 | 0,01 | 37,5 | 0 ÷ 40 ÷ 0 | 16,5 |
| 074111367 | 1,6 | 0,01 | 30 | 0 ÷ 40 ÷ 0 | 16,5 |
| 074111368 | 0,4 | 0,002 | 37,5 | 0 ÷ 10 ÷ 0 | 15,2 |
| 074111369 | 0,4 | 0,002 | 30 | 0 ÷ 10 ÷ 0 | 15,2 |

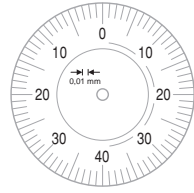

074111366



074111367

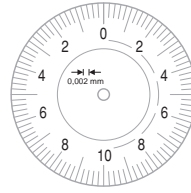

074111368

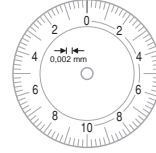

074111369



INTERRAPID 312 Perpendicular Models

| No | mm | mm | ∅, mm | | Insert, mm |
|-----------|-----|------|-------|------------|------------|
| 074111375 | 1,6 | 0,01 | 37,5 | 0 ÷ 40 ÷ 0 | 16,5 |
| 074111376 | 1,6 | 0,01 | 30 | 0 ÷ 40 ÷ 0 | 16,5 |

Dial Test Indicator Sets, Complete with Accessories – INTERRAPID 312 Standard Models

Each full set consists of:



| No | |
|-----------|--|
| | INTERRAPID 312 lever test indicators as listed in the table below: |
| 074106331 | Rectangular mounting attachment |
| 074108942 | Reducing sleeve, metric |
| 074106026 | Swivel holder, metric |
| 074111474 | Case for measuring inserts |
| 01860307 | Wrench for measuring inserts |

| No | 074111366 | 074111367 | 074111368 | 074111369 | 074106331 | 074108942 | 074106026 | 074111474 | 01860307 |
|-----------|-----------|-----------|-----------|-----------|-----------|-----------|-----------|-----------|----------|
| 074111502 | ● | | | ● | ● | ● | ● | ● | ● |
| 074111503 | | ● | | ● | ● | ● | ● | ● | ● |
| 074111504 | | | ● | ● | ● | ● | ● | ● | ● |
| 074111505 | | | ● | ● | ● | ● | ● | ● | ● |



Rotating dial



Very low measuring force: (see table for tolerance limits)



Lever system with friction drive to prevent overload



Accuracy: see table for tolerance limits



Supplied in a plastic case with:
1 with a ∅ 2 mm insert in hardened steel,
1 stylus key
No. 01860307



Declaration of conformity



Technical data: see description for each product



Plastic case



Declaration of conformity



M1,7 coupling thread

Ball tips in hardened steel or tungsten carbide

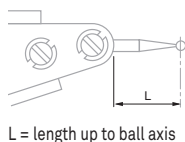

Measuring Inserts

| No | mm | Ball tip, mm | Ball tip material | L mm |
|-----------|-------|--------------|-------------------|------|
| 074107893 | 0,01 | 2 | Steel | 16,5 |
| 074107895 | 0,01 | 1,5 | Steel | 16,5 |
| 074107897 | 0,01 | 0,8 | Steel | 16,5 |
| 074110481 | 0,002 | 2 | Steel | 15,2 |
| 074110492 | 0,002 | 1,5 | Steel | 15,2 |
| 074110493 | 0,002 | 0,8 | Steel | 15,2 |
| 074105993 | 0,01 | 2 | Carbide | 16,5 |
| 074105994 | 0,01 | 1,5 | Carbide | 16,5 |
| 074105995 | 0,01 | 0,8 | Carbide | 16,5 |
| 074106358 | * | 2 | Carbide | 36,6 |
| 074106360 | * | 0,8 | Carbide | 36,6 |
| 074110482 | 0,002 | 2 | Carbide | 15,2 |
| 074110491 | 0,002 | 1,5 | Carbide | 15,2 |
| 074110507 | 0,002 | 0,8 | Carbide | 15,2 |

* The length of the insert used changes the amplification factor of the lever system. The values read off must therefore be doubled.



Accessories for INTERAPID 312

Clamping Attachment

| No | = | mm |
|-----------|--|-----|
| 074108603 | Double attachment with clamping point and dovetail | ∅ 4 |

Holders

| No | = | mm |
|-----------|---|------------------------------------|
| 074106026 | Swivel holder with clamping points and dovetail | ∅ 8 x 133 (∅ 4 for clamping point) |

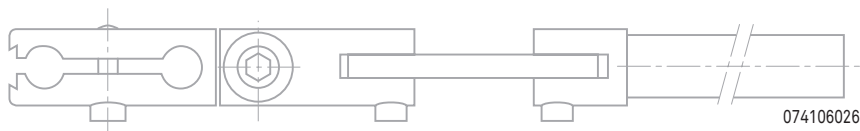

Clamping Attachment

| No | = | mm |
|-----------|--|-----------|
| 074106331 | Rectangular clamping attachment complete | ∅ 8 / ∅ 4 |

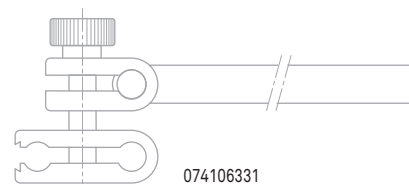

Reducing Sleeve

| No | = | mm |
|-----------|-----------------|-----------|
| 074108942 | Reducing sleeve | ∅ 8 / ∅ 4 |

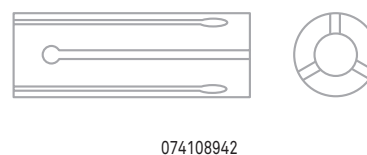

COMPAC DIAL TEST INDICATORS

Essential for the workshop, but also in the inspection room or measuring laboratory – Ideal for comparative measurement on a surface plate – Detect form and position errors – Measure axial and radial runouts, especially.

Technical Features

- Long measuring travel, up to 3 mm.
- Bidirectional measuring, without reversing lever.
- Same rotation direction of pointers in the two measuring directions (clockwise pointer direction).
- Swivelling probe through 180°.
- Main pivot on self-aligning angular bearings, dimensioned oversize.
- Dovetail mounting machined in the indicator housing.
- Dull chrome-plated bezel and housing.
- Rotating dial.
- Insensitive to magnetic fields generated in mechanical workshops.

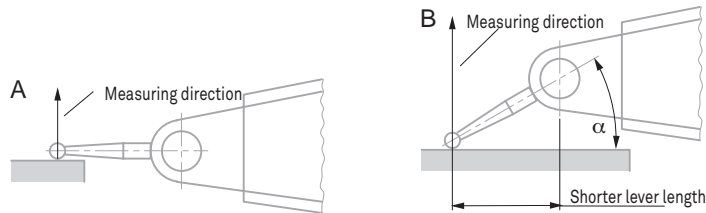

Note for use of COMPAC dial test indicators

With the measuring insert lying parallel to the workpiece surface (Fig. A), these dial test indicators give true reading due to the amplification factor of 1:1. In any other measuring position (angle α in Fig. B), the effective lever length changes. The values indicated need be corrected. In this connection, please consult the instruction manual.

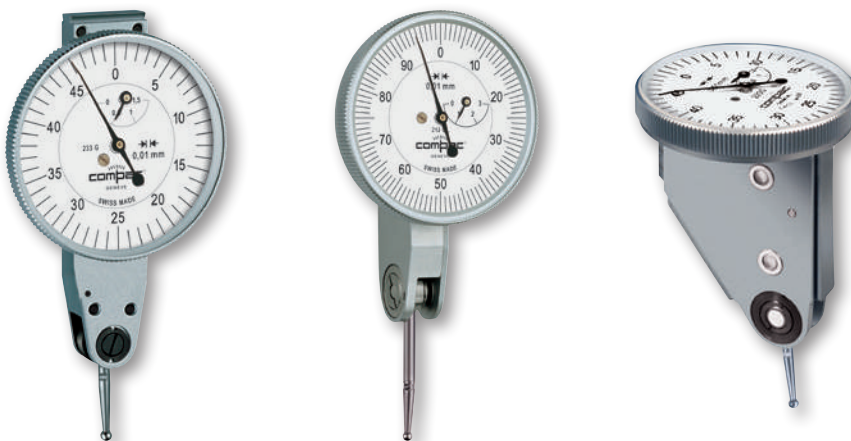

COMPAC Series 210 – Standard Models, Metric

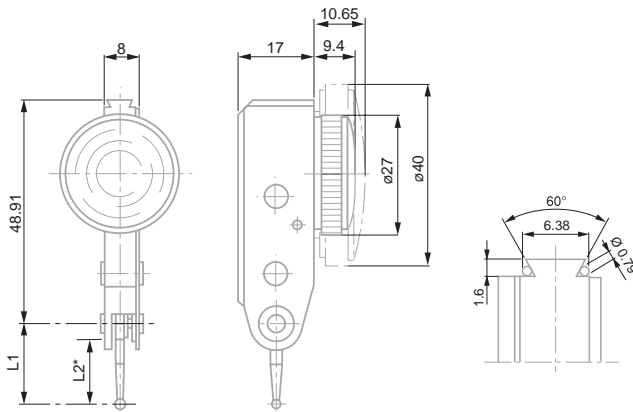

L2; see table of inserts for COMPAC lever-type test indicators

- DIN 2270 and factory standard
- Rotating dial
- Contact points with tungsten carbide ball tips
- Friction lever system to prevent overload
- Supplied in a plastic case, including:
1 contact point, 2 mm dia.
1 rigid stem 8 mm dia., L = 15 mm, No. 01840107
1 rigid stem 4 mm dia., L = 15 mm, No. 01840109 (except for series 220).
- Serial number
- Inspection report with a declaration of conformity

| No | Total travel, mm | μm | μm | μm | μm | Travel/revolution, mm | \varnothing , mm | \varnothing , mm | N | Insert L1, mm |
|-------|------------------|---------------|---------------|---------------|---------------|-----------------------|--------------------|--------------------|--------|---------------|
| 213 | 1,5 | 0,01 | 13 | 3 | 3 | 0,5 | 27 | 0 ÷ 25 ÷ 50 | ≤ 0,35 | 18 |
| 213G | 1,5 | 0,01 | 13 | 3 | 3 | 0,5 | 40 | 0 ÷ 25 ÷ 50 | ≤ 0,35 | 18 |
| 212L | 3 | 0,01 | 26 | 3 | 6 | 1 | 27 | 0 ÷ 50 ÷ 100 | ≤ 0,20 | 36 |
| 212GL | 3 | 0,01 | 26 | 3 | 6 | 1 | 40 | 0 ÷ 50 ÷ 100 | ≤ 0,20 | 36 |
| 215 | 0,6 | 0,002 | 13 | 1,5 | 2,5 | 0,1 | 27 | 0 ÷ 5 ÷ 10 | ≤ 0,30 | 18 |
| 215G | 0,6 | 0,002 | 13 | 1,5 | 2,5 | 0,1 | 40 | 0 ÷ 5 ÷ 10 | ≤ 0,30 | 18 |
| 215GL | 1,2 | 0,002 | 26 | 1,5 | 5 | 0,2 | 40 | 0 ÷ 10 ÷ 20 | ≤ 0,20 | 36 |
| 216G | 0,6 | 0,001 | 13 | 1,5 | 2,5 | 0,1 | 40 | 0 ÷ 5 ÷ 10 | ≤ 0,30 | 18 |

COMPAC Series 220 – Perpendicular Models, Metric

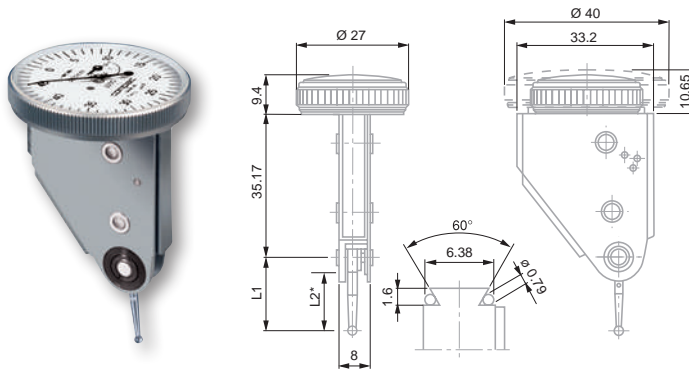

*L2 see table of inserts for COMPAC lever-type test indicators

| No | Total travel, mm | μm | μm | μm | μm | Travel/revolution, mm | \varnothing , mm | \varnothing , mm | N | Insert L1, mm |
|-------|------------------|---------------|---------------|---------------|---------------|-----------------------|--------------------|--------------------|--------|---------------|
| 223 | 1,5 | 0,01 | 13 | 3 | 3 | 0,5 | 27 | 0 ÷ 25 ÷ 50 | ≤ 0,35 | 18 |
| 223G | 1,5 | 0,01 | 13 | 3 | 3 | 0,5 | 40 | 0 ÷ 25 ÷ 50 | ≤ 0,35 | 18 |
| 222L | 3 | 0,01 | 26 | 3 | 6 | 1 | 27 | 0 ÷ 50 ÷ 100 | ≤ 0,20 | 36 |
| 222GL | 3 | 0,01 | 26 | 3 | 6 | 1 | 40 | 0 ÷ 50 ÷ 100 | ≤ 0,20 | 36 |
| 225 | 0,6 | 0,002 | 13 | 1,5 | 2,5 | 0,1 | 27 | 0 ÷ 5 ÷ 10 | ≤ 0,30 | 18 |
| 225G | 0,6 | 0,002 | 13 | 1,5 | 2,5 | 0,1 | 40 | 0 ÷ 5 ÷ 10 | ≤ 0,30 | 18 |



COMPAC 230 Parallel Models

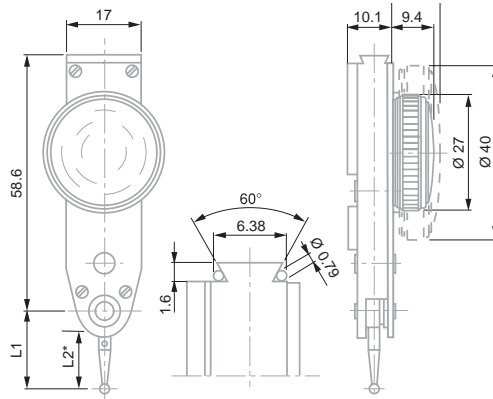

* L1 see table of inserts for COMPAC lever-type indicators

| No | Total travel, mm | mm | µm | µm | µm | Travel/revolution, mm | Ø, mm | N | Insert L1, mm |
|-------|------------------|-------|----|-----|-----|-----------------------|-------|---------------------|---------------|
| 233 | 1,5 | 0,01 | 13 | 3 | 3 | 0,5 | 27 | 0 ÷ 25 ÷ 50 ≤ 0,35 | 18 |
| 233G | 1,5 | 0,01 | 13 | 3 | 3 | 0,5 | 40 | 0 ÷ 25 ÷ 50 ≤ 0,35 | 18 |
| 232L | 3 | 0,01 | 26 | 3 | 6 | 1 | 27 | 0 ÷ 50 ÷ 100 ≤ 0,20 | 36 |
| 232GL | 3 | 0,01 | 26 | 3 | 6 | 1 | 40 | 0 ÷ 50 ÷ 100 ≤ 0,20 | 36 |
| 235G | 0,6 | 0,002 | 13 | 1,5 | 2,5 | 0,1 | 40 | 0 ÷ 5 ÷ 10 ≤ 0,30 | 18 |



DIN 2270 and factory standard



Rotating dial



Contact points with tungsten carbide ball tips



Friction lever system to prevent overload



Supplied in a plastic storage case, including:
1 contact point, 2 mm dia.
1 rigid stem 8 mm dia. L = 15 mm, No. 01840107,
1 rigid stem 4 mm dia., L = 15 mm, No. 01840109



Serial number



Inspection report with a declaration of conformity

COMPAC 240 Reduced Range Models

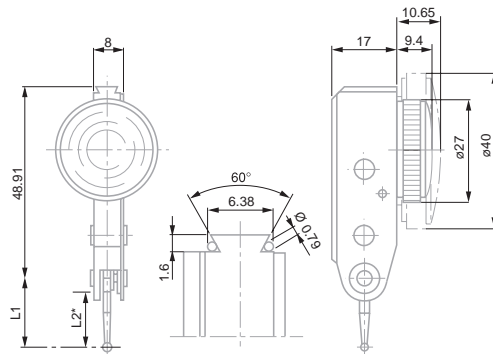

* L2 see table of inserts for COMPAC lever-type indicators

| No | Total travel mm | mm | µm | µm | µm | Ø, mm | N | Insert L1, mm |
|-------|-----------------|-------|----|-----|-----|-------|-------------------|---------------|
| 242 | 0,8 | 0,01 | 13 | 3 | 3 | 27 | 0 ÷ 40 ÷ 0 ≤ 0,25 | 18 |
| 242G | 0,8 | 0,01 | 13 | 3 | 3 | 40 | 0 ÷ 40 ÷ 0 ≤ 0,25 | 18 |
| 243L | 0,5 | 0,01 | 13 | 3 | 3,5 | 27 | 0 ÷ 25 ÷ 0 ≤ 0,10 | 45 |
| 243GL | 0,5 | 0,01 | 13 | 3 | 3,5 | 40 | 0 ÷ 25 ÷ 0 ≤ 0,10 | 45 |
| 245 | 0,2 | 0,002 | 4 | 1,5 | 2 | 27 | 0 ÷ 10 ÷ 0 ≤ 0,25 | 18 |
| 245G | 0,2 | 0,002 | 4 | 1,5 | 2 | 40 | 0 ÷ 10 ÷ 0 ≤ 0,25 | 18 |



M1,6 coupling thread



The original inserts mounted on all indicators are fully interchangeable with inserts with different diameter tips as long as the insert has the same nominal length.

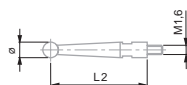

L1 = Axial length from ball to pivot



01866014

Measuring Inserts for COMPAC Models

| No | Ball tip, mm | Ball tip material | L1, mm | L2, mm |
|----------|--------------|-------------------|--------|--------|
| 01866014 | 0,8 | Carbide | 18 | 14,26 |
| 01866003 | 2 | Carbide | 18 | 14,26 |
| 01866021 | 3 | Carbide | 18 | 14,26 |
| 01866016 | 0,8 | Carbide | 36 | 32,26 |
| 01866004 | 2 | Carbide | 36 | 32,26 |
| 01866023 | 3 | Carbide | 36 | 32,26 |
| 01866015 | 0,8 | Carbide | 45 | 41,26 |
| 01866006 | 2 | Carbide | 45 | 41,26 |
| 01866022 | 3 | Carbide | 45 | 41,26 |
| 01866026 | 2 | Ruby | 18 | 14,26 |
| 01866027 | 2 | Ruby | 36 | 32,26 |

Accessories for COMPAC

Swivel Clamps



SPT

| No | Stem | Clamping length |
|------|--------|-----------------|
| SPT | 8 mm | 25 mm |
| SPTA | 1/4 in | 1 in |

Mounting Rods with Dovetail Grip

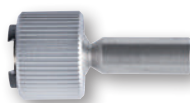

01850106

| No | | |
|----------|--|--------|
| 01850106 | Fixing shank swivelling through +/-30° | 1/4 in |
| 01850107 | Rigid fixing shank | 1/4 in |
| 01840106 | Fixing shank swivelling through +/-30° | 8 mm |
| 01840107 | Rigid fixing shank Ø8mm | 8 mm |
| 01840108 | Fixing shank swivelling through +/-30° | 4 mm |
| 01840109 | Rigid fixing shank Ø4mm | 4 mm |





Clamp

| No | = |  |
|----------|--------------------------------------|---|
| 01860401 | Dovetail clamp with tightening screw | mm Ø 5,6 / Ø 9,5 |



01860401

Mounting Rods

| No | = |  |
|----------|------------------------------|---|
| 01840404 | Short swivel holder | mm Ø 8 x 25 |
| 01840405 | Long swivel holder | Ø 8 x 90 |
| 01840406 | Angular swivel holder | Ø 8 x 25 (Ø 8 for clamping bore) |
| 01840501 | Centering holder | Ø 8 x 25 (Ø 4 for clamping point) |
| 01840407 | Long sw. holder, fine adjust | Ø 8 x 125 |



01840501



01840404



01840405



01840406



01840407

Fixing Shank

| No | = |  |
|----------|----------------------------------|---|
| 01840104 | Mounting rod | mm Ø 4 |
| 01840105 | Mounting rod with dovetail clamp | Ø 8 |
| 01840202 | Cylindrical fixing shank | Ø 8 x 80 (Ø 5,6 for the tenon) |
| 01860008 | Mounting rod | Ø 6 |

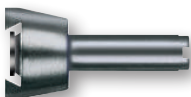

01840104



01840105



01840202

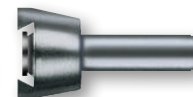

01860008



Comparative Measurement



TESA YA COMPLETE INSTRUMENT SETS

Specially designed for small bores from 0,47 up to 12,20 mm - Checking of dimension and bore form errors through 2-point measuring - Offers an excellent repeatability. The YA bore gauges consist of an interchangeable measuring head with a built-in needle and handle with a 8 mm diameter fixing bore for a dial gauge or any other type of sensor

- Measuring heads with spherical faces for through bores.
- Measuring heads for particularly deep bores.

Can be supplied on request:

- Measuring heads with carbide measuring faces.
- Measuring heads for special applications.
- Measuring heads for blind bores and particularly deep bores with other application ranges.
- Carbide measuring needles.
- Depth extensions 125, 250, 500, 750 and 1000 mm.

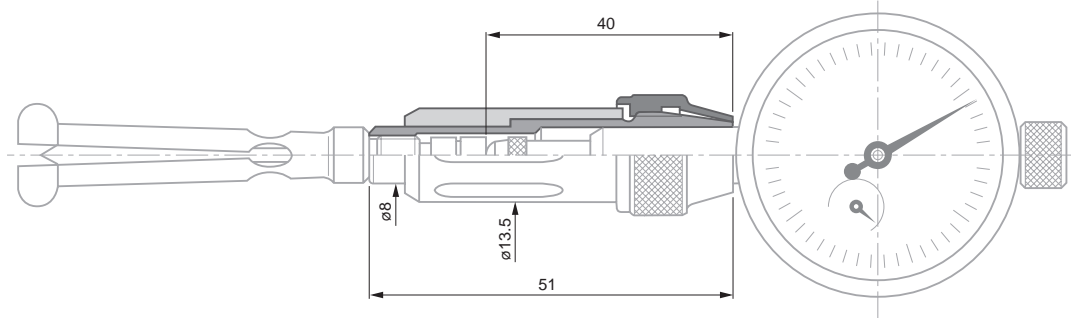
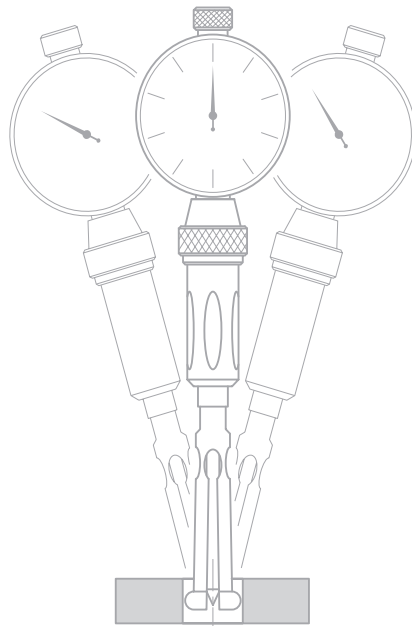

COMPLETE INSTRUMENT SETS FOR MEASURING THROUGH BORES



See table



1 μ m



Reliability of engraved dimension:
 $\pm 2s = 1 \mu$ m



Measuring head in hardened steel and carbide, ≈ 1000 HV 25
Measuring needles in hardened steel, ≈ 800 HV 25
Setting rings: with synthetic sapphire for nominal $\varnothing \leq 1,5$ mm and hardened steel for $> 1,5$ mm, ≈ 780 HV 25



Holder: Mounting of instruments with stem $\varnothing 8$ h6 mm



Technical data: see component sets



Complete set includes:
1 handle No. 01540201.
Measuring heads, needles and setting rings as shown in the table below.
1 TESA COMPAC dial gauge No. 353 (reading to 0,01 mm, $\varnothing 40$ mm dial)
1 Extension for for inserts, 10 mm No. 03540501.



Plastic case



Declaration of conformity



mm

| | |
|----------|--------------|
| 01510000 | 0,47 ÷ 0,97 |
| 01510100 | 0,95 ÷ 2,45 |
| 01510200 | 2,30 ÷ 6,20 |
| 01510300 | 6,00 ÷ 12,20 |

| | Measuring heads | mm | Measuring depth max. mm | Measuring depth min. mm | Needles | Setting rings mm | | |
|---------------------------------|-----------------|--------------|-------------------------|-------------------------|----------|------------------|----------|------|
| COMPOSITION OF THE SETS: | | | | | | | | |
| 01510000 | 01540401 | 0,47 ÷ 0,53 | 1,5 | 0,25 | 01540001 | 01540601 | 0,50 | |
| | 01540402 | 0,52 ÷ 0,58 | 1,8 | 0,27 | 01540001 | 01540602 | 0,55 | |
| | 01540403 | 0,57 ÷ 0,67 | 2,0 | 0,29 | 01540002 | 01540603 | 0,60 | |
| | 01540404 | 0,65 ÷ 0,77 | 2,5 | 0,31 | 01540002 | 01540604 | 0,70 | |
| | 01540405 | 0,75 ÷ 0,87 | 2,8 | 0,33 | 01540002 | 01540605 | 0,80 | |
| | 01540406 | 0,85 ÷ 0,97 | 3,0 | 0,35 | 01540002 | 01540606 | 0,90 | |
| 01510100 | 01540407 | 0,95 ÷ 1,15 | 11 | 0,6 | 01540003 | 01540607 | 1,00 | |
| | 01540408 | 1,07 ÷ 1,25 | 11 | 0,6 | 01540003 | 01540608 | 1,10 | |
| | 01540409 | 1,17 ÷ 1,35 | 11 | 0,6 | 01540003 | 01540609 | 1,20 | |
| | 01540410 | 1,27 ÷ 1,45 | 11 | 0,6 | 01540003 | 01540610 | 1,30 | |
| | 01540411 | 1,37 ÷ 1,55 | 11 | 0,6 | 01540003 | 01540611 | 1,40 | |
| | 01540412 | 1,50 ÷ 1,90 | 17 | 0,9 | 01540004 | 01540612 | 1,50 | |
| | 01540413 | 1,70 ÷ 2,15 | 17 | 0,9 | 01540004 | 01540613 | 1,75 | |
| | 01540414 | 2,05 ÷ 2,45 | 17 | 0,9 | 01540004 | 01540614 | 2,00 | |
| | | | | | 01540615 | 2,25 | | |
| 01510200 | 01540415 | 2,30 ÷ 2,75 | 22 | 1,2 | 01540005 | 01540616 | 2,50 | |
| | 01540416 | 2,65 ÷ 3,20 | 22 | 1,2 | 01540005 | 01540617 | 3,00 | |
| | 01540417 | 3,05 ÷ 3,50 | 22 | 1,2 | 01540005 | 01540618 | 3,25 | |
| | 01540418 | 3,35 ÷ 3,85 | 22 | 1,2 | 01540005 | 01540619 | 3,50 | |
| | 01540419 | 3,80 ÷ 4,30 | 22 | 1,2 | 01540005 | 01540620 | 4,00 | |
| | 01540420 | 4,20 ÷ 5,00 | 40 | 2,0 | 01540006 | 01540621 | 4,50 | |
| | 01540421 | 4,70 ÷ 5,50 | 40 | 2,0 | 01540006 | 01540622 | 5,00 | |
| | 01540422 | 5,30 ÷ 6,20 | 40 | 2,0 | 01540006 | 01540623 | 5,75 | |
| | 01510300 | 01540423 | 6,00 ÷ 6,80 | 40 | 2,0 | 01540006 | 01540624 | 6,50 |
| | | 01540424 | 6,60 ÷ 7,50 | 40 | 2,0 | 01540006 | 01540625 | 7,00 |
| 01540425 | | 7,30 ÷ 8,15 | 40 | 2,0 | 01540006 | 01540626 | 7,75 | |
| 01540426 | | 8,00 ÷ 8,80 | 40 | 2,0 | 01540006 | 01540627 | 8,50 | |
| 01540427 | | 8,50 ÷ 9,40 | 50 | 2,0 | 01540006 | 01540628 | 9,00 | |
| 01540428 | | 9,15 ÷ 10,00 | 50 | 2,0 | 01540006 | 01540629 | 9,50 | |
| 01540429 | | 9,60 ÷ 10,80 | 50 | 3,3 | 01540007 | 01540630 | 10,00 | |
| 01540430 | 10,65 ÷ 12,20 | 50 | 3,3 | 01540007 | 01540631 | 11,50 | | |



Special Executions

Available upon request :

- Full instrument sets for measuring blind bores and short centering shoulders.
- Measuring heads with tungsten carbide tipped measuring faces.
- Measuring heads for special applications.
- Measuring heads for through bores, particularly deeper ones covering other application ranges.
- Tungsten carbide measuring needles.
- 125, 250, 500, 750 and 1000 mm depth extensions.

Optional Accessories for TESA YA Bore Gauges

Measuring stand for stationary use.



For technical details, see INTERRAPID UA30 measuring supports



Declaration of conformity



01639009 INTERRAPID UA 30 Support

MUST BE EQUIPPED WITH:

01610201 UK 25 sliding arm.
Used with TESA YA for stationary bore measurement on UA30 support.

01640000 UAZ 10 depth stop plate for UA 30



TESA VERIBOR

Proven design and reliability never questioned over decades – Instruments for 2-point measurements for bores from 4,5 up to 550 mm – Detects form errors – Gauge body with a 8 mm diameter clamping bore for a dial gauge, precision indicator or any other sensor.

- Excellent repeatability due to the circular element fixed on the instrument ensuring practically no play.
- Gauge body made of invar steel to neutralise the influence of the operator's hand warmth on the measuring result.
- Centring shoe for correct alignment of the instrument in the bore.
- Tungsten carbide ball tips for high resistance to wear.

TESA VERIBOR Light

Instrument with 2 contact points for comparative measurement of bores and detection of form errors – Automatic self-centering in the bore – Can be used with a dial gauge, a precision indicator or a probe with $\varnothing 8h6$ clamping stem.

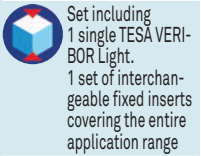
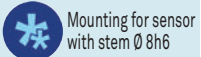
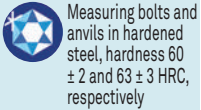

| No | = | Measuring bolt travel, mm | mm | Measuring depth, mm |
|----------|--------------------|---------------------------|----------|---------------------|
| 05710090 | TESA Veribor light | 1,30 | 18 ÷ 35 | 176 |
| 05710091 | TESA Veribor light | 1,40 | 35 ÷ 60 | 178 |
| 05710092 | TESA Veribor light | 1,40 | 50 ÷ 150 | 178 |
| 05710093 | TESA Veribor light | 1,30 / 1,40 | 18 ÷ 150 | 176 / 178 |

Sets delivered without dial gauge



TESA VERIBOR



See table of values



Only VERIBOR without dial gauge: $2 \mu\text{m}$



Only VERIBOR without dial gauge: $\pm 2s = 0,5 \mu\text{m}$



Measuring bolts and anvils fitted with carbide ball tips



Mounting for sensor with stem $\varnothing 8 \text{ h}6 \text{ mm}$



Set including 1 single TESA VERIBOR. 1 set of interchangeable fixed inserts covering the whole application range.



Wooden case



Declaration of conformity

| No | mm |
|----------|-----------|
| 05710012 | 4,5 ÷ 6 |
| 05710013 | 6 ÷ 12,5 |
| 05710014 | 12 ÷ 25 |
| 05710015 | 25 ÷ 50 |
| 05710016 | 50 ÷ 150 |
| 05710018 | 50 ÷ 300 |
| 05710017 | 240 ÷ 550 |

Sets supplied without dial gauges, electronic probes or indicators

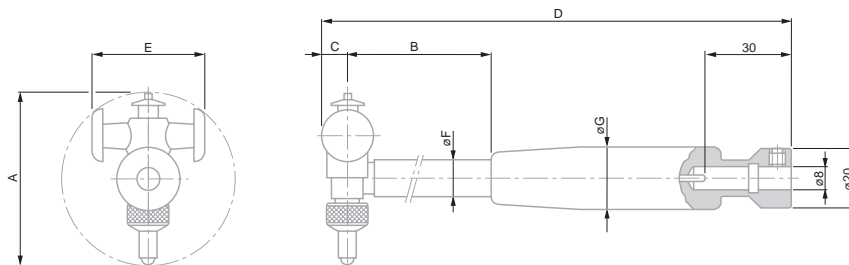

| A mm | mm | B mm | C mm | D mm | E mm | F mm | G mm |
|-----------|------|------|------|------|---------|------|------|
| 4,5 ÷ 6 | 0,35 | 74 | 2 | 138 | 3,3 | 3,8 | 16 |
| 6 ÷ 12,5 | 0,5 | 93 | 2,6 | 156 | 4,3 | 4,9 | 16 |
| 12 ÷ 25 | 0,9 | 106 | 4,5 | 194 | 7,8 | 7,9 | 19 |
| 25 ÷ 50 | 1,3 | 140 | 6 | 228 | 16 | 8 | 19 |
| 50 ÷ 150 | 1,4 | 173 | 10 | 279 | 36 | 12 | 23 |
| 50 ÷ 300 | 1,4 | 173 | 10 | 279 | 36 / 66 | 12 | 23 |
| 240 ÷ 550 | 1,6 | 227 | 14 | 347 | 112 | 18 | 28 |

Special Versions

Available on request :

- TESA VERIBOR for blind bores and centring shoulders.
- TESA VERIBOR elbow-shaped for hard-to-reach bores.
- Handtools for measuring the distance between two plan-parallel surfaces.
- Handtools for inspecting gear pitch diameters.



ACCESSORIES FOR TESA VERIBOR

Set of Extensions

For extending the application range to \varnothing 300 mm for VERIBOR No. 05710016, 05710058 et 05710065.

| No | = |  |
|----------|-------------------|--|
| 05740001 | Set of extensions | Consisting of – 1 Centring shoe – 3 Extensions 50 mm |



Depth Extensions

To be mounted on the body of VERIBOR $\varnothing \geq 25 \leq 550$ mm for large measuring depths (dimension B in the technical drawing of the VERIBOR).

| No | = |  |
|----------|-----------|--|
| 05760029 | Extension | mm 1000 |
| 05760027 | Extension | 500 |



Dial Gauge Protection Guard

Protects the dial gauge against direct shocks and prevents the dial from being inadvertently rotated.

| No | = |  |
|----------|------------------|--|
| 05760013 | Protection guard | mm \varnothing 58 |



ARM GAUGES

Very practical comparative measuring instrument – Measures at 2 or 3 points depending on the accessory used – Ideal for blind or through bores – also suited for measuring grooves, flutes as well as the internal measurement of parts with parallel faces.

IRA 2 Comparative Gauge

- Large application range from 10 to 150 mm
- Easy to handle thanks to its light weight and ergonomic design
- Built-in indicator with 0,01 mm reading and fine setting
- Centering device for 2-point measurement

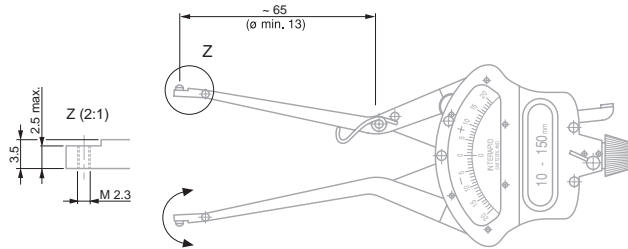
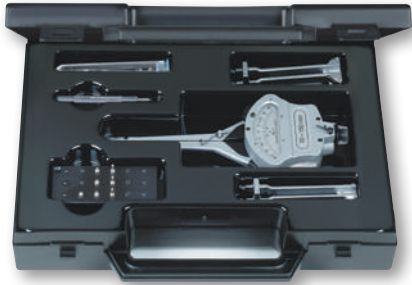

| No | = | A |
|--|---|----|
| 079105704 | INTERAPID IRA 2 | mm |
| 079111401 | INTERAPID IRA 2, carbide | mm |
| DELIVERED WITH THE FOLLOWING ACCESSORIES: | | |
| 079105667 | 3 inserts, hardened steel (order number for 1 unit, with 079105704) | |
| 079105756 | 3 inserts, carbide (order number for 1 unit, with 079111401) | |
| 079105668 | 3 short inserts, hardened steel (order number for 1 unit) | |
| 079105669 | 3 long inserts in hardened steel (order number for 1 unit) | |
| 079112126 | 2 inserts, adjustable for internal dia. >6mm | |
| 079110110 | Large insert holder for 3-point measurement | |
| 079108502 | IRA centering arm, Ø 15-30 mm | |
| 079110111 | Small insert holder for 3-point measurement | |
| 079105694 | Special screwdriver for IRA set | |

Optional Accessories for IRA-2 Comparative Gauge

| No | = |
|-----------|--|
| 079112051 | Small insert set for 3-point measurement |
| 079112052 | Long insert set pour 3-point measuring |

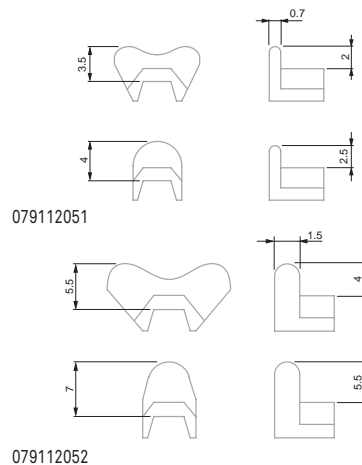
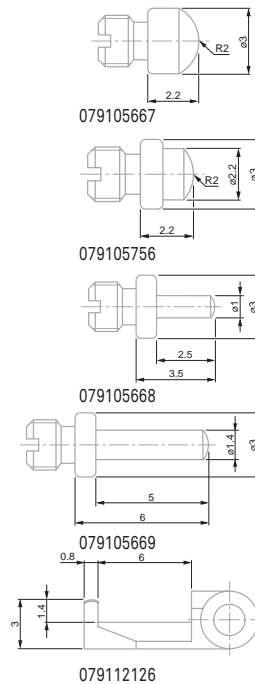
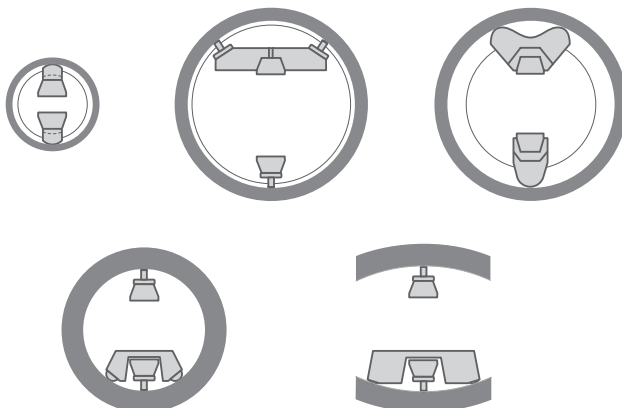

- ± 0,20 mm or ± 0,008 in
- 10 ÷ 150 mm 0.375 ÷ 6 in
- 0,01 mm or 0.0005 in
- Measuring inserts in hardened steel or tungsten carbide, see opposite table
- 3,5 N
- Measuring arm clearance travel: 10 mm
- Plastic case
- Declaration of conformity



- Chrome plated, hardened steel



Ø 57 mm

0,2 mm

Dial gauge: 5 µm

30 mm throat depth.
Highly stable frame
with heat insulating
handle.

≈ 2 N

Non-interchan-
geable measur-
ing inserts. With device
for retraction of
inserts.

Cardboard box

Declaration of
conformity

THICKNESS GAUGES

Designed for the direct measurement of thickness of all types of materials: plastics, glass, wood, felt, paper, rubber, etc.

Each gauge is equipped with a rotating dial for zero setting.

Model for Sheets



074115664 Thickness gauge for sheets

mm
0 ÷ 1

mm
0,001

Flat, mm
Ø 6,35



Ø 57 mm

10 mm

Dial gauge: 40 µm

Interchangeable
measuring inserts

Cardboard box

Declaration of
conformity

Models with Open Inserts When Not in Use



| | mm | mm | mm | mm | Paired inserts included |
|-----------|--------|-----|----|----------------|-------------------------|
| 074115604 | 0 ÷ 30 | 0,1 | 50 | flat; Ø 30 | 074115686 |
| 074115605 | 0 ÷ 30 | 0,1 | 50 | flat; Ø 20 | 074115687 |
| 074115606 | 0 ÷ 30 | 0,1 | 50 | flat; Ø 10 | 074115726 |
| 074115607 | 0 ÷ 30 | 0,1 | 50 | convex; Ø 10 | 074115727 |
| 074115608 | 0 ÷ 30 | 0,1 | 50 | spherical; Ø 5 | 074115728 |



INTERAPID SHE.30 & SHE.35 SMALL HORIZONTAL MEASURING BENCHES

Extremely practical and very precise, these measuring benches are mainly used for the inspection of batches of precision parts as used in the watch making and precision mechanical sectors – Rapid measuring and easy setting from one part to the other – Wide choice of measuring inserts specially designed for the most varied of metrology applications.

INTERAPID SHE.30 for External Dimensions



| | |
|----------------------------|---|
| | |
| 03330004 | INTERAPID SHE 30 small measuring horizontal bench for external dimensions (without measuring inserts) |
| OPTIONAL ACCESSORY: | |
| 03360300 | Measuring inserts, carbide, length 3,5 mm, height 0,4 mm |

Measuring inserts, either cylindrical or knife-edged are available on request.

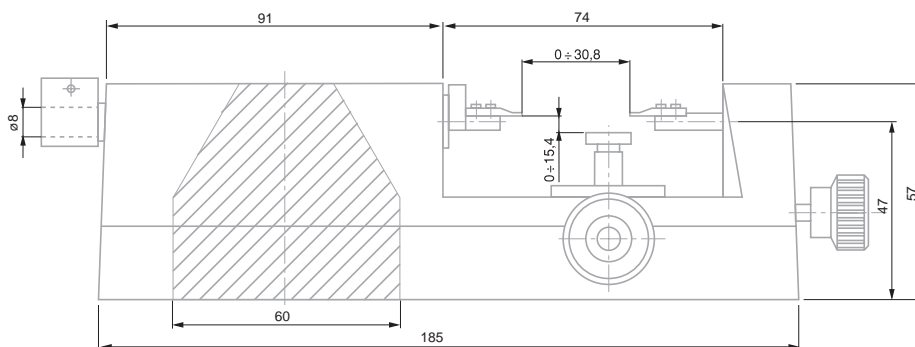

Pair of Measuring Inserts in Special Version

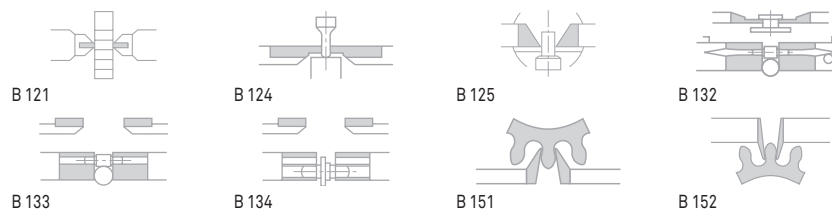

0 to 30 mm



Accuracy is usually influenced by the measuring instrument used as well as both flatness and parallelism of the measuring faces of inserts.

Holder precision: Flatness tolerance of two clamping faces: 0,05 mm. Axial positioning tolerance for the two indexing pins with respect to bolt axis: 0,05 mm. Tolerance for the parallelism of the table surface with respect to the bolt axis: 0,05 mm. See drawing



Main body in cast iron. Other parts in steel, hardened and ground



Produced by sensor used. The SHE.30 model is not spring-loaded.



Mobile measuring bolt: guided on a smooth bearing surface and equipped with a semi-circular disc for bolt retraction. Measuring inserts, assembled in pairs, and mounted on the measuring bolt and fixed anvil with a 1 mm diameter pin and 2 M1,4 screws. Support table with possibility of vertical and longitudinal adjustment: Surface 24 x 9,5 mm. Adjustment range: vertical: 15 mm, longitudinal: 14 mm. With fixing screw. Sensor (not included in the supply for SHE 30 bench): electronic indicator, mechanical or precision dial gauge, axial analogue or digital probe with mounting shank of Ø 8 mm



2,1 kg



Transport packaging



Declaration of conformity

INTERAPID SHE.35 for Internal Dimensions

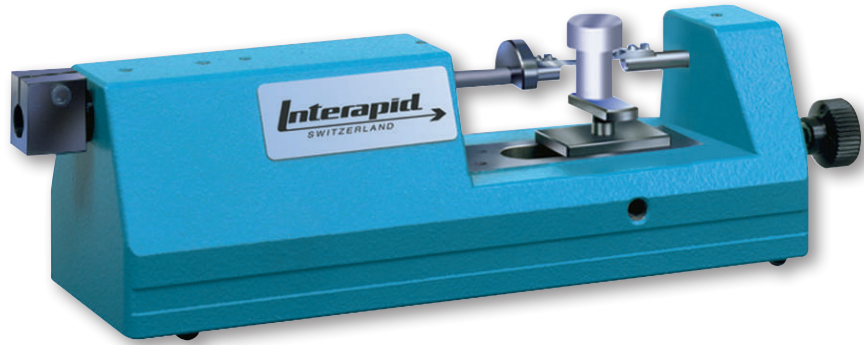

30 mm



8 to 38 mm (standard accessory)



Accuracy is generally influenced by the measuring instrument as well as the type of inserts used.



Main body in cast iron. Other parts in hardened and ground steel. Inserts with carbide measuring faces.



Produced by sensor used. The SHE.35 bench is not equipped with a spring.



Mobile measuring bolt guided on a flat bearing surface, also fitted with a retracting ball-shaped handle. Interchangeable measuring inserts supplied in pairs. Fixing shaft \varnothing 4 mm. Height adjustable support table. Surface: 40 x 70 mm. Setting range: 8 mm. 1 tightening screw. Sensor (must be ordered separately), e.g. dial gauge, electronic or precision indicator, analogue or digital probe. Mounting \varnothing 8 mm.



2,3 kg



Transport packaging



Declaration of conformity



03330006 INTERAPID SHE 35 small horizontal measuring bench for internal dimensions (with measuring inserts)

8 ÷ 38 mm

Inserts with special design also available on request

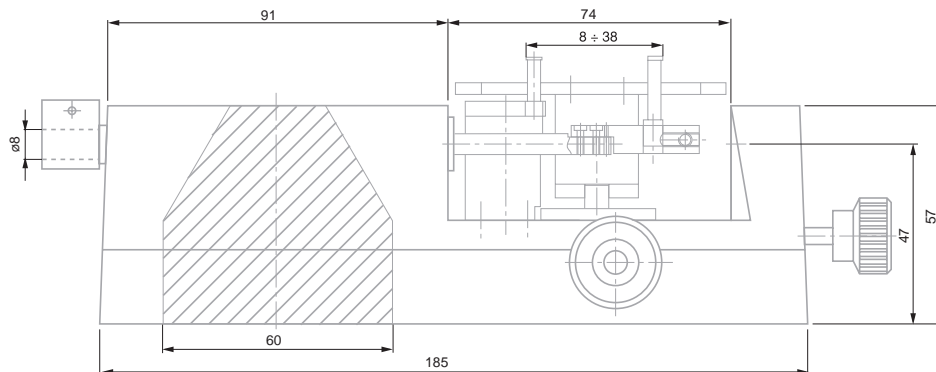





Measuring Supports and Auxiliary Equipment



TESA measuring supports have been designed to offer the best holding stability for instruments such as dial gauges, lever dial test indicators and probes. Stability is the prime requirement needed to reduce the related uncertainties in a measurement method or set-up.





A Base with vee recess and 1 magnetic flat face. Disengageable of magnet possible. Duralumin articulations.



Dovetail clamp with a \varnothing 8 mm clamping bore



0,4 kg



Supplied without indicator



Transport packing



Declaration of conformity

UNIVERSAL SUPPORTS

Magnetic measuring support with suction base or articulated arm.

INTERAPID Magnetic Support with Articulated Arm (small)

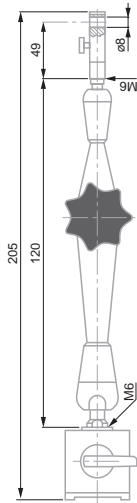

Magnetic support with articulated arm

| No | = | N | H mm | L mm | Base mm | Consisting of: |
|----------|---|-------|------|------|--------------|--|
| 01639025 | Small magnetic measuring stand with articulated arm | ≈ 170 | 205 | 120 | 30 x 30 x 30 | <ul style="list-style-type: none"> - 1 articulated arm length 120 mm - 1 dovetail clamp with fine adjustment - 1 magnetic base 30 x 30 x 30 (L x W x H) |



A Magnetic base has 1 prismatic and 2 flat faces. Articulations made from duralumin. Disengageable permanent magnet. Dovetail clamp with a \varnothing 8 mm clamping bore.



Supplied without measuring instrument



Suitable transport packing



Declaration of conformity

INTERAPID Magnetic Support with Articulated Arm

Simple and secure locking using a single rotating knob
- highly rigid arm and articulation.

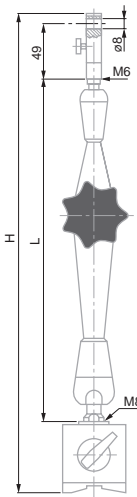

Magnetic support with articulated arm

| No | = | N | V-Base for \varnothing , mm | Fine adjust | H mm | L mm | Base mm | Mass kg | Consisting of: |
|----------|---|-------|-------------------------------|-------------|------|------|--------------|---------|---|
| 01639022 | INTERAPID magnetic support with articulated arm | ≈ 800 | 30 ÷ 150 | ● | 310 | 200 | 60 x 50 x 55 | 1,45 | <ul style="list-style-type: none"> - Articulated arm - Clamp - Magnetic base |
| 01639023 | INTERAPID magnetic support with articulated arm | ≈ 800 | 30 ÷ 150 | ● | 390 | 280 | 60 x 50 x 55 | 1,85 | <ul style="list-style-type: none"> - Articulated arm - Clamp - Magnetic base |



INTERAPID Magnetic Support with High Precision Articulated Arm

Magnetic support with high precision articulated arm and fine adjustment for measurements that need repeatability in the range of μm .

Simple and secure locking with a two-position knob. Highly rigid arm and articulation.

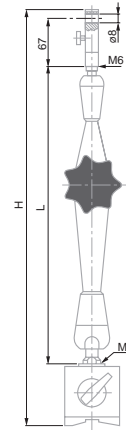

Magnetic support with high precision articulated arm



A Magnetic base has 1 prismatic and 2 flat faces. Articulations made from duralumin. Disengageable permanent magnet. Dovetail clamp with a $\varnothing 8$ mm clamping bore.



Supplied without measuring instrument



Suitable transport case



Declaration of conformity

| No | = | | | | | | | |
|----------|--|----------------|-------------------------------|-------------|------|------|--------------|---|
| | | N | V-Base for \varnothing , mm | Fine adjust | H mm | L mm | Base mm | Consisting of: |
| 01639053 | INTERAPID High Precision Magnetic Support with Articulated Arm | ≈ 1000 | $30 \div 150$ | ● | 440 | 320 | 73 x 50 x 55 | <ul style="list-style-type: none"> - Articulated Arm - Clamp - Magnetic base |

INTERAPID Magnetic Support with Flexible Arm

For measurements in hard to reach locations. Instant and reliable locking through lever control.

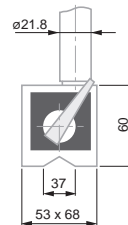

| No | = | |
|----------|------------------------------------|--|
| 01639020 | Magnetic Support with Flexible Arm | |



Holding force on a flat surface ≈ 1000 N



The magnetic base has 1 prismatic and 2 flat faces. Disengageable permanent magnet. Full length 350 mm. Dovetail clamp with an $\varnothing 8$ mm clamping bore.



Supplied without measuring instrument



Suitable transport packing



Declaration of conformity



A Switchable magnet. Clamp with Ø 8 mm clamping bore

Supplied without measuring instrument

Suitable transport packing

Declaration of conformity

INTERAPID Inclinable Magnetic Support

Standard model and models with strong holding force



01639017



01639019

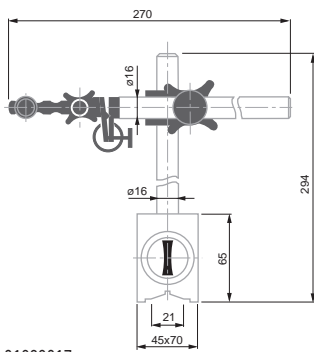

01639017

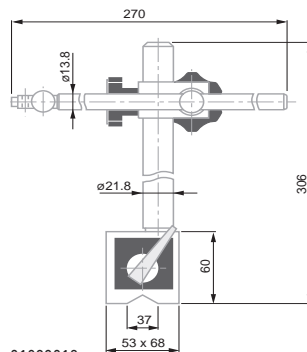

01639018

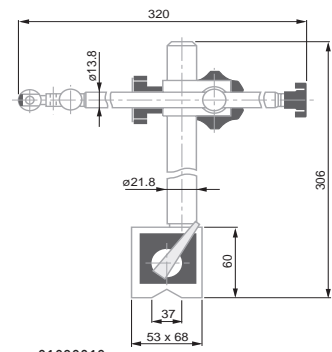

01639019



| No | = | N | V-Base for Ø, mm | A | Fine adjust |
|----------|--|--------|------------------|-------------------------------|-------------|
| 01639017 | INTERAPID magnetic support with V-base, 600 N | ≈ 600 | 70 ÷ 220 | Standard Version | ● |
| 01639018 | INTERAPID magnetic support with V-base, 1000 N | ≈ 1000 | 70 ÷ 220 | Strong magnetic holding force | — |
| 01639019 | INTERAPID magnetic support with V-base, 1000 N | ≈ 1000 | 70 ÷ 220 | Strong magnetic holding force | ● |



INTERAPID Support with Suction Base and Articulated Arm

Holds firmly on any smooth and flat surface

- Clamps instantly and reliably using a suction lever switch.
- Highly rigid articulated arm.
- Free from magnetic fields.

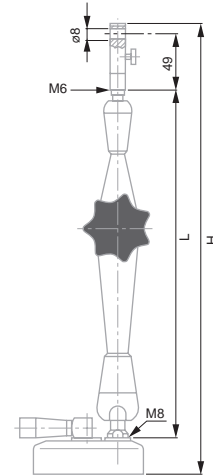

Round suction base made of aluminium (Ø 88 mm, height 28 mm) with flat suction base. Articulations made from duralumin. Suction controlled by lever switch. Dovetail clamp with an Ø 8 mm clamping bore.



1.1 kg



Supplied without measuring instrument



Suitable transport packing



Declaration of conformity



N



Fine adjustment



H, mm



L, mm



Consisting of:

01639024

INTERAPID Measuring support with suction base and articulated arm

≈ 400

●

363

280

- Articulated arm
- Fine adjust clamp
- Round suction base





Measuring table and column in hardened steel.

A Measuring arm with $\varnothing 8$ mm clamping bore, without fine adjustment. Measuring span: 48 mm.

2,7 kg

Supplied without measuring instrument

Suitable transport packing

Declaration of conformity

INTERAPID Small Measuring Support and Table $\varnothing 49$ mm

Round steel measuring table

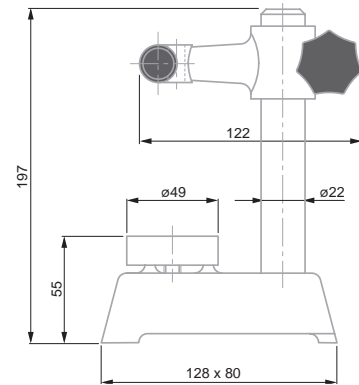

Application example with DIGICO indicator



01639006 INTERAPID small support with $\varnothing 49$ mm measuring table

mm

0 ÷ 100

mm

49

INTERAPID Measuring Support with Inclined Frontal Arm



Cast iron base

A Base with front support face. Clamp for $\varnothing 8$ mm mounting rod or dial gauge with lug back. Model No 01639003 also with dovetail clamp.

1,3 kg (01639003)
4,35 kg (01639004)

Supplied without dial gauge

Packed suitable for transport

Declaration of conformity



01639003

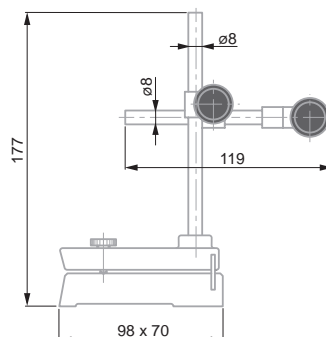

01939003



01639004

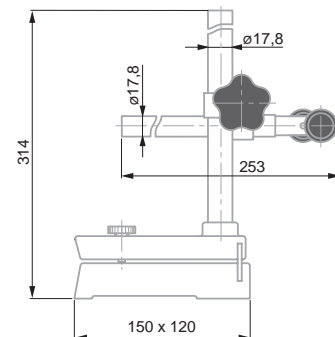

01939004



01639003 INTERAPID Measuring Support with Inclined Frontal Arm H = 177 mm

01639004 INTERAPID Measuring Support with Inclined Frontal Arm H = 314 mm

Used in conjunction with:
Lever dial test indicators, small dial gauges
Lever dial test indicators, small dial gauges, precision indicators, probes etc.



INTERAPID UA 1 Table Measuring Support with Ground Table Surface

Basic model without fine adjustment

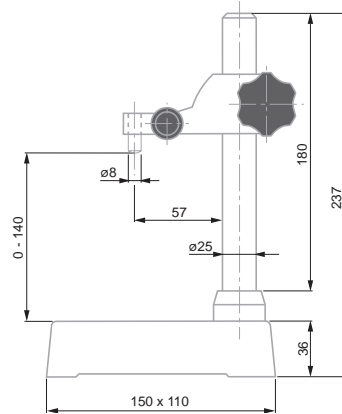

| | | | |
|----------|---|---------|-----------|
| | | | |
| 01639008 | INTERAPID UA 1 measuring support with table | 0 ÷ 140 | 100 x 100 |



Measuring table: cast iron. Column: chrome-plated steel, Arm: spheroidal graphite cast iron.



Measuring surface of table: ground. Column: Can be dismantled. Measuring arm with Ø 8 mm clamp.



3 kg



Supplied without measuring instrument



Suitable transport packing



Declaration of conformity

INTERAPID UD12 Support

Medium sized mobile measuring support for use with ever type dial test indicators, dial gauges, precision indicators, electronic probes etc.

With fine adjustment mechanism.

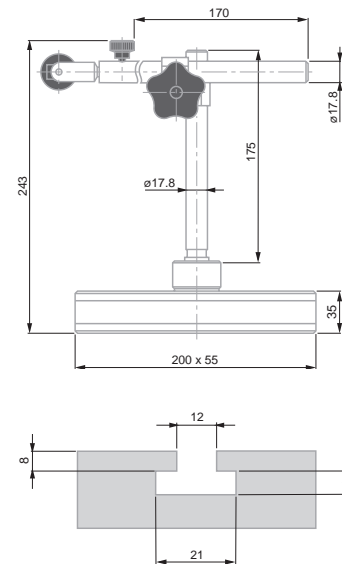

| | | | |
|-------------|--|--|--|
| | | | |
| 01639000 | UD 12 universal support | | |
| COMPOSÉ DE: | | | |
| 01840105 | Tige de fixation à queue d'aronde Ø 8 mm | | |
| 01640100 | UDZ 3 Mounting rod and UDZ3 clamp Ø 8 mm clamp for UD 12 | | |



Cast iron base



Stand with lateral guiding faces. T-slot for vertical column. 2 rigid articulations



3.3 kg



Supplied without measuring instrument



Suitable transport packing



Declaration of conformity

INTERAPID Table Measuring Stands with Granite Grade 00



3 µm in accordance with DIN 876 T1, class 00



01639035: black burnished column with Ø 8 mm clamping bore.

01639029: chrome plated column with thread and threaded ring for adjusting the height of the measuring arm. Ø 8 mm clamping bore. Grooved measuring face.

01639030: Chrome plated column. Tilting measuring arm and joint. Ø 4 mm or 8 mm bore for a dovetail clamp or lug.

01639033: Chrome plated column. Horizontal sliding arm. Ø 4 mm or 8 mm bore for a dovetail clamp or lug.



Supplied without measuring instrument



Suitable transport packing



Declaration of conformity

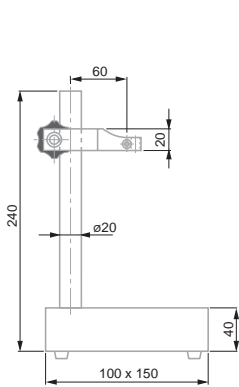

01639035

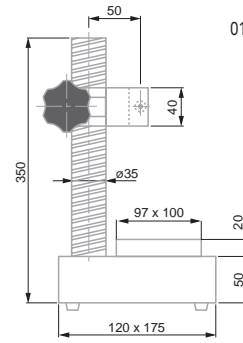

01639029

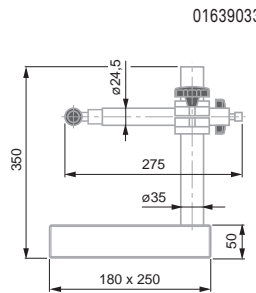

01639033

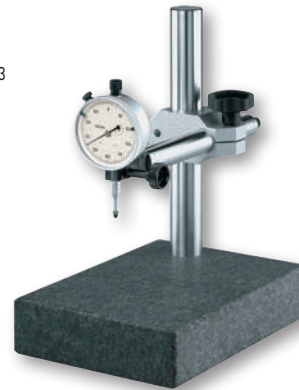

| No | = | | | | | | | | | |
|----------|--|---------|----|-------------------|-----------------|--------------------|------------------|--------------------|------------|------|
| | | mm | mm | Measuring surface | Fine adjustment | Measuring table mm | Column height mm | Working surface mm | Span mm | kg |
| 01639035 | Table measuring support with granite, column Ø 20 | 0 ÷ 170 | 20 | Granite | – | 100 x 150 x 40 | 200 | 100 x 115 | 50,0 | 2,6 |
| 01639029 | Slotted table measuring support with granite, threaded column Ø 35 | 0 ÷ 225 | 35 | Hardened steel | ● | 120 x 175 x 50 | 300 | 100 x 100 | 68,5 | 8,1 |
| 01639033 | Table measuring support with granite, column Ø 35 | 0 ÷ 260 | 35 | Granite | ● | 180 x 250 x 50 | 300 | 180 x 200 | Adjustable | 10,5 |



SMALL MAGNETIC SUPPORTS

Ideal for lever type dial test indicators, and dial gauges up to 40 mm diameter
- With 2 articulation joints and fine adjustment.

UJ 15 Model

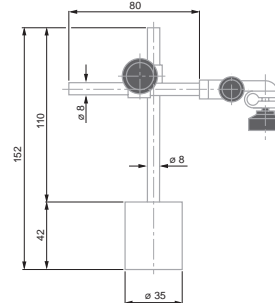

01639007 Magnetic support INTERAPID UJ15, dovetail clamp and $\varnothing 8$ mm cylindrical clamping

UJ 15G Model

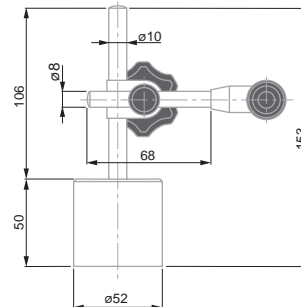

01639016 UJ Magnetic support

Accessories for Small Magnetic Stands



01640501 Steel base plate for UJ15 or UJ15G that become movable



Holding force on a flat surface: ≈ 220 N



Rounded base with permanent magnet



0,47 kg



Supplied without indicator



Packed suitable for shipping



Declaration of conformity



Holding force on a flat surface: ≥ 350 N



Rounded base with permanent magnet



0,93 kg



Supplied without indicator



Packed suitable for shipping



Declaration of conformity



50 x 80 x 20 mm



0,60 kg



Cast iron table.
Chrome plated steel
column



Suitable transport
packing



Declaration of
conformity



Support base:
Ground measuring
face. 2 T-slots. Re-
movable column.



Supplied without
sensor



Support base only:
4,85 kg
Measuring arm:
0,85 kg
Sliding arm: 1,75 kg

UA 30 MEASURING STAND

Base for mounting special fixtures adapted for series inspection

INTERAPID UA 30 Measuring Stand, Without Measuring Arm

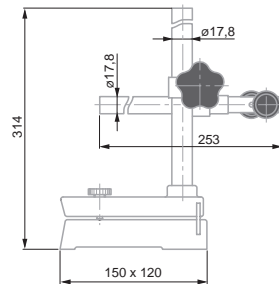

01639009

INTERAPID UA 30 measuring support with
table, without measuring arm

0 ÷ 175

0 ÷ 6.89

125 x 115



Measuring arm
01610200: With
fine adjustment. 1
mm travel. Ø 8 mm
clamping bore.
Sliding arm
01610201: Sliding
holder for TESA
YA dial gauges.
Adjustable swinging
movement. Clamp-
ing bore Ø 13 mm.
Length of travel
35, 57 or 80 mm.
Measuring span
60 mm. Depth stop
plate 01640000:
Dimensions: 115 x
35 x 3,5 mm.
120° vee recess for
Ø ≤ 120 mm, 2 tight-
ening screws.

Accessories for UA 30



01610200



01610201

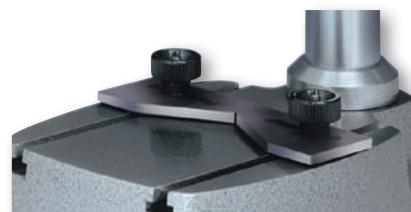

01640000



01610200

UK 20 measuring arm with fine adjustment for UA30 support

01610201

UK 25 sliding arm. Used with TESA YA for stationary bore measurement on UA30 support

01640000

UAZ 10 depth stop plate for UA 30



EQUIPEMENT AUXILIAIRES

INTERAPID Depth Foot with a Flat Face



| | | | |
|-----------|---------------------------|----|---------|
| No | = | | |
| 01639046 | Depth foot with flat face | mm | 80 x 16 |
| | | | 8 |

INTERAPID Depth Foot with Prismatic Measuring Face

For measuring the depth of key slots on cylindrical shafts and determining circularity errors etc.



| | | | | | | | |
|-----------|--|-------------|-------------|----------|----------|----------|----------|
| No | = | | | | | | |
| 01639047 | Depth foot with prismatic measuring face | Diameter mm | Diameter in | Width mm | Width in | Clamp mm | Clamp in |
| | | 10 ÷ 100 | 0.39 ÷ 3.9 | 16 | 0.64 | 8 | 0.315 |

Brown & Sharpe CENTER FINDER Centering Tool

Practical for aligning the centre of a bore with respect to the spindle axis of a machine tool

- Without the clamping shaft, it can also serve as small magnetic support
- Allows the clamping of a dial test indicator, either a standard or perpendicular model.



| | |
|-----------|----------------------------------|
| No | = |
| 06769006 | B&S CENTER FINDER centering tool |



Hardened steel



Lapped measuring faces. Clamp with lock for mounting a dial gauge or probe



Supplied without sensor



Suitable transport packing



Declaration of conformity



Hardened steel



Lapped measuring faces. Clamp with lock for mounting a dial gauge or probe



Supplied without sensor



Suitable transport packing



Declaration of conformity



Center Finder consisting of the following components:

- cylindrical shank for clamping on the chuck of a machine tool.
- powerful round magnetic base with strong holding capacity.
- swivel joint and dovetail collar for clamping a lever-type dial test indicator.



Wooden case



Hardened steel



Ground finish for support and vee faces



Not available as individual components



Suitable transport packing

Brown & Sharpe V-Block Set with Clamping Bridge

V-blocks with frames for clamping cylindrical parts diameters ranging from 0,7 to 40 mm.

Can be used for machining or inspecting workpieces

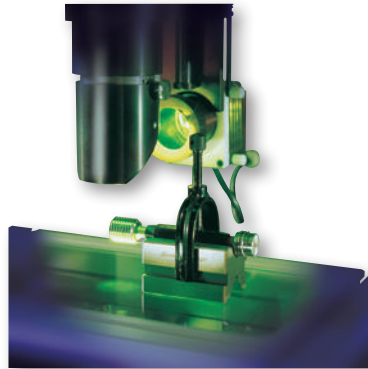

| No | = | ∅ | ∅ | Icon | Consisting of: |
|----------|---------------------|--------------------|--------------------|------|--|
| | | Clamping Range, mm | Clamping Range, in | | |
| 06769007 | Set of B&S V-blocks | 0,7 ÷ 40 | 0.3 ÷ 9/32 | | 1 pair of V-blocks 5 ÷ 40 mm 1 extra V-block 3 ÷ 8 mm 1 extra V-block 1,5 ÷ 5 mm 5 extra V-blocks 0,7 ÷ 3,5 mm 2 in-between bridges 2 large frames 1 small frame |



7 µm for each pair



2,5 µm for the 6 faces



Hardened steel, 55 to 60 HRC



Each block has 18 through bores Ø 9,53 mm and 5 bores with M10 threads



Supplied with five M10 socket head screws and one 8 mm socket wrench



Plastic case

Brown & Sharpe Positioning Block Set

Pair of matched blocks used for positioning and holding workpieces or for use as stops on granite surface plates, a coordinate measuring set-up, a machine-tool or other applications - Each block are precision ground.

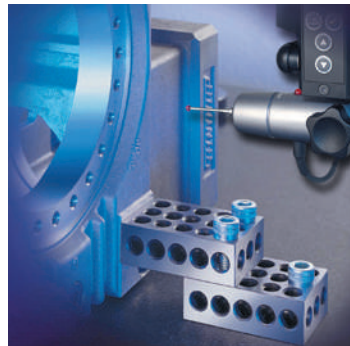

| No | = | Icon | Icon |
|----------|---|--------------|--------------------|
| | | mm | in |
| 06769004 | Positioning block set, precision ground | 75 x 50 x 25 | 2.95 x 1.95 x 0.98 |



Brown & Sharpe Adjustable Parallels

Set consists of 6 adjustable parallels.

Used as parallel pads, setting standards for measuring instruments or gauges for checking internal dimensions on parallel surfaces.

Each parallel consists of two tapered parts dovetailed together. – Two tightening screws lock the parallels to the size required.



Hardened steel



Supplied with a PH 1 screwdriver



Plastic pouch

| | | | | |
|-----------------|-------------------------|--------------|-------------|--|
| No | = | | | |
| 06769010 | Adjustable parallel set | | | |
| Consisting of: | | | | |
| = | ⚙ | ⚙ | | |
| | Height mm | Length mm | Width mm | |
| 1 parallel | 10 ÷ 13 | 44 | 7 | |
| 1 parallel | 13 ÷ 17 | 54 | 7 | |
| 1 parallel | 17 ÷ 24 | 68 | 7 | |
| 1 parallel | 24 ÷ 33 | 90 | 7 | |
| 1 parallel | 33 ÷ 44 | 106 | 7 | |
| 1 parallel | 44 ÷ 57 | 129 | 7 | |



ROCH Flexible Rules

In spring stainless steel - Divisions of 1 mm and 0.5 mm.



Class CE II



Stainless spring-loaded steel



Suitable transport packing



Declaration of conformity



| | | | | |
|-------------------|--------------------------------|--------------|-------------|-----------------|
| No | = | ⚙ | ⚙ | ⚙ |
| | | Length mm | Width mm | Thickness mm |
| 0951750181 | ROCH flexible rule L = 200 mm | | | |
| 0951750182 | ROCH flexible rule L = 300 mm | | | |
| 0951750184 | ROCH flexible rule L = 500 mm | | | |
| 0951750187 | ROCH flexible rule L = 1000 mm | | | |



Length L = 100 mm,
Width = 13 mm max.



Allloyed steel



Blades not supplied individually



Plastic pouch



Declaration of conformity

ROCH Thickness Gauges



| No | = | Thickness mm | Incrément mm | Thickness in. | Number of blades |
|------------|---|---|----------------|---------------------|------------------|
| 0951753013 | | ROCH thickness gauge with 13 blades, 0,05 to 1,0 mm 0,05 ÷ 0,3 / 0,4 ÷ 1,0 | 0,05 / 0,1 | 0.001968 ÷ 0.003937 | 6/7 |
| 0951753014 | | ROCH thickness gauge with 20 blades: 0,05 to 1,0 mm 0,05 ÷ 1,0 | 0,05 | 0.001968 ÷ 0.003937 | 20 |
| 0951753015 | | ROCH thickness gauge with 21 blades; 0,1 to 0,2 mm 0,1 ÷ 2,0 | 0,1 + 1 x 0,05 | 0.003937 ÷ 0.07874 | 21 |

ROCH Radius Gauges

Set of radius gauges with concave and convex blades.
Designed for visual inspection of radii.

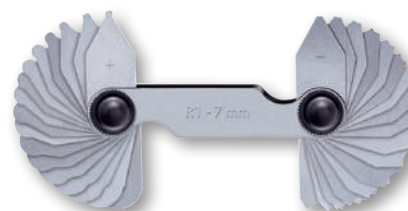

| No | = | Radius mm | Radii mm | Incrément mm | Number of blades |
|------------|---|--|---------------------------|--------------|------------------|
| 0951753001 | | ROCH Radius Gauge 2 x 17 blades 0,1 | 1,0 ÷ 2,75 / 3,0 ÷ 7,0 | 0,25 / 0,5 | 2 x 17 |
| 0951753002 | | ROCH radius gauge 2 x 16 blades 0,15 | 7,5 ÷ 15,0 | 0,5 | 2 x 16 |
| 0951753003 | | ROCH radius gauge 2 x 15 blades 0,2 | 15,5 ÷ 19,5 / 20,0 ÷ 25,0 | 0,2 | 2 x 15 |

ROCH Screw Pitch Gauges

60° flank angles for ISO metric threads
or 55° for Whitworth threads.



| No | = | Thread pitch mm | Threads per in | Metric thread |
|------------|---|---|--|----------------------------------|
| 0951753045 | | ROCH screw pitch gauge for ISO 60° threads 0,25 / 0,3 / 0,35 / 0,4 / 0,45 / 0,5 / 0,6 / 0,7 / 0,75 / 0,8 / 0,9 / 1,0 / 1,25 / 1,5 / 1,75 / 2,0 / 2,5 / 3,0 / 3,5 / 4,0 / 4,5 / 5,0 / 5,5 / 6,0 | - | ISO 60° mm |
| 0951753046 | | ROCH screw pitch gauge - Whitworth 55° threads | 62 / 60 / 48 / 40 / 36 / 32 / 30 / 28 / 26 / 25 / 24 / 22 / 20 / 19 / 18 / 16 / 14 / 13 / 12 / 11 / 10 / 8 / 7 / 6 / 5 / 4,5 / 4 | Whitworth 55° (threads per inch) |



Stainless steel



Blades are not supplied individually



Plastic pouch



Declaration of conformity



Allloyed steel



Blades are not supplied individually



Plastic pouch



Declaration of conformity



ROCH Portable Magnifier

With a folding handle and additional magnifier. – Retractable support.



Solid resistant plastic



Cardboard box



Declaration of conformity

| No | = |  |  |  |  |
|------------|-------------------------|---|---|---|---|
| | | Large magnifier | Small magnifier | mm | Small magnifier, mm |
| 0951754511 | ROCH portable magnifier | 3x | 10x | 80 x 45 | 13 |



Straightness, Angle and Inclination Measurement



INCLINOMETERS AND PRECISION LEVELS

Irrespective of whether they are spirit or electronic inclinometers, all precision levels are based on the same perfectly reliable reference but also cost-free: the centre of the earth's gravity.

Under the force of gravity, the gas bubble in the liquid or the pendulum inclines itself according to this natural physical principle.

The position of the pendulum with respect to the measuring faces of the instrument body can then be measured. Based on this perfect principle, these instruments offer a great number of measuring applications of high precision. The horizontal and vertical positioning of the measuring faces enable the detection of form errors in the geometrical elements on the workpiece to be measured.

These errors often result from deviations in straightness, flatness, position, parallelism and squareness.

Indication of values may vary depending on the type of level, the values typically displayed are:

- inclination (mm/m or in/10 in);
- radian in mrad;
- decimal angle (e.g. 12,37°);
- sexagesimal angle in degrees (°), minutes (') and seconds (") e.g. 15° 30' 45".



TESA MICROBEVEL 1



TESA CLINOBEVEL
1 USB



TESA CLINOBEVEL 2



TESA NIVELTRONIC



Spirit clinometers with
angle protractor



INCLINOMETERS AND LEVELS

The TESA inclinometers and levels meet the most demanding applications not only in the machine building sector but also in the civil construction sector.

Electronic Inclinometer - TESA CLINOBEVEL 1 USB

Compact universal instrument for direct and differential measurements – Measuring range $\pm 45^\circ$ with display of measured angles or inclinations – Reinforced aluminium housing, eloxide surface – Large digital display for error free interpretation of readings.

Supplied with CLINOSOFT software permitting the visualisation and storage of measurements as well as the USB cable to host computer.

Multiple applications are possible, notably the measurement of 2 flat surfaces by comparing the measured values with the help of 2 instruments. Automatic generation of inspection reports using Microsoft EXCEL spreadsheet software.

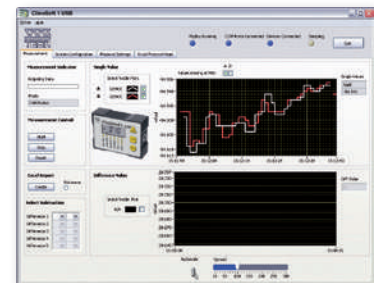

CLINOSOFT Software



Measuring functions: A ; B ; A+B ; A-B



CLINOSOFT Software

CLINOBEVEL 1-USB, can be used on its 4 faces.

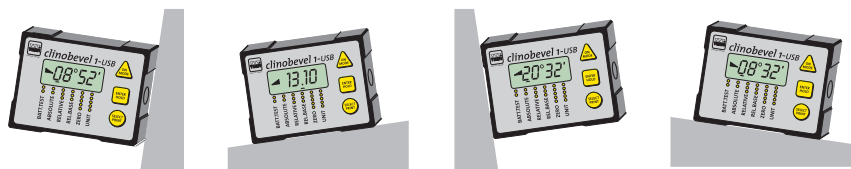

- DIN 2276 Part 2 (Form D)
- LCD angle display: Decimal or sexagesimal
Inclination mm/m, in/10 or 12 in, mm or in/basis length, radian (mrad) and the like
- Capacitive measuring system with gravity pendulum
- 2' + 1 numerical interval
- 21 storable correction values (high accuracy)
- Flat face 4 x 90°
- 100 x 75 x 35 mm
- Anodised light alloy
- Response time ≈ 1 s
- Automatic shut down after 8 min
- Display lock
- RS485, asynchronous, 7 bits, 2 stop bits, no parity, 9600 bauds
- 1 1,5 V battery, type LRC 6, AA
- ≈ 150 hours
- 0 to 40°C
- 20 to 70°C
- IP65 (IEC 60529)
- EN 50081-1 / -2
EN 50082-1 / -2
- 0,52 kg
- Plastic case
- Identification number
- Inspection report with declaration of conformity

| | | | | | |
|----------|--|----------------|-------------|------------|---|
| | | | | | |
| 05330203 | CLINOBEVEL 1 USB electronic inclinometer | $\pm 45^\circ$ | $\geq 0,02$ | mm/m mm | Livré avec: CLINOSOFT software plus USB cable to host computer |

OPTIONAL ACCESSORIES:

- 04768002 4 batteries LRC 6 AA, 1,5 V for CLINOBEVEL 1 USB, CLINOBEVEL 2, MICROBEVEL,
- 05360006 External switch with cable, L = 2 m, for CLINOBEVEL 1 USB
- 05360014 External switch, wireless, for CLINOBEVEL 1 USB



TESA CLINOBEVEL 2 Electronic Inclinometer

Portable precision inclinometer.

Measuring range $\pm 45^\circ$ with indication of angle or inclination.

Integrated temperature compensation 2 prismatic measuring faces.

Spirit level integrated in transverse direction to eliminate "twist" error.

Simple and rapid calibration: correction of gain by the 3-point method and software integrated in the instrument.

Microprocessor-based features for display setting and instrument adjustment.

The CLINOBEVEL 2 can be used on its two reference faces.

It can also be connected to a second CLINOBEVEL 2 instrument for a differential measurement (Comparative): one of the two instruments operates as a reference without the need to connect to a computer.

The integrated RS 232 interface enables the connection of the instrument to a computer.

Magnetic inserts can be integrated on the measuring faces on request as a special execution.

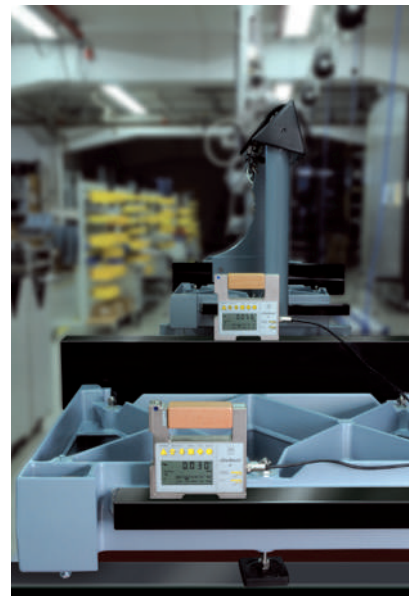

When 2 CLINOBEVEL 2 are connected, one of the instruments becomes the reference

- DIN 2276 Part 2 (Form D)
- LCD angle display: Decimal or sexagesimal Inclination mm/m, in/10 or 12 in, mm or in/ basis length, radian (mrad) and the like
- Capacitive measuring system with gravity pendulum
- $10'' \pm 0,03\%$ of the readout
- 2 flat measuring faces with V-slot for diameters from $\varnothing 17$ to 94 mm
- $150 \times 150 \times 35$ mm
- Rust inhibiting housing
- Response time: < 5 s
- Automatic shut down after 8 min
- RS 232 asynchronous. 7 bits, 2 stop bits, no parity, 9600 bauds
- 2 batteries 1,5 V, type LRC 6, AA
- 40 to 60 hours
- 0 to 40°C
- -20 to 70°C
- IP65 (IEC 60529)
- EN 50081-1 / -2
EN 50082-1 / -2
- 3 kg
- Plastic case
- Identification number
- Declaration of conformity

| | | | | |
|------------------------------|---|----------------|-------------------------------------|----------------------|
| | | | | |
| 05330202 | Electronic Inclinometer TESA CLINOBEVEL 2 | $\pm 45^\circ$ | $\geq 5''$ (5 Arcsec = 0,025 mm/mm) | mm 100 x 150 x 35 |
| OPTIONAL ACCESSORIES: | | | | |
| 04768002 | 4 batteries LRC 6 AA, 1,5 V for CLINOBEVEL 1 USB, CLINOBEVEL 2, MICROBEVEL, | | | |
| 05360004 | Connecting cable between 2 CLINOBEVEL 2, L = 2,5 m | | | |
| S53070174 | Câble USB pour CLINOBEVEL 2, L=2,5 m | | | |

TESA MICROBEVEL 1 Inclinometer

TESA MICROBEVEL 1 is particularly suited for measuring slightly inclined surfaces such as the measuring of flatness of surfaces or the geometrical characteristics (deviation, rotation etc.) of a machine tool.

Suited for operation under the most rugged conditions., protected by an aluminium case.

Power supplied by a single standard battery AA 1,5 V for at least 100 hours of operation.



Horizontal model



Square model

Models with steps 0,05 to 0,005 mm/m available on request

| No | = | | | | |
|----------------------------|---|--------------------------|----------------|-----------------|--------------------------|
| | | Range 1 or Range 2, mm/m | Base width, mm | Base height, mm | kg (with transport case) |
| 05330003 | TESA MICROBEVEL 1 horizontal base 110 x 45 mm | 0,01 ou 0,001 | 110 | 45 | 1,8 |
| 05330004 | TESA MICROBEVEL 1 horizontal base 150 x 45 mm | 0,01 ou 0,001 | 150 | 45 | 2,1 |
| 05330005 | TESA MICROBEVEL 1 square base 150 x 45 mm | 0,01 ou 0,001 | 150 | 45 | 3,1 |
| OPTIONAL ACCESSORY: | | | | | |
| 04768002 | 4 batteries LRC 6 AA, 1,5 V for CLINOBEVEL 1 USB, CLINOBEVEL 2, MICROBEVEL, | | | | |

| Range | | | | | |
|-------|------|------|-------|--|--|
| | mm/m | mm/m | mm | G = mm/m | |
| 1 | ± 20 | ± 5 | 0,01 | Flatness ≤ 5 mm/m G = 1 % of the measured value and min. 0,01 mm/m | Flatness > 5 mm/m G = 0,01 mm/m |
| 2 | ± 2 | ± 2 | 0,001 | Flatness ≤ 1 mm/m G = 1 % of the measured value and min. 0,001 mm/m | Flatness > 1 mm/m G = 1 % of (2x measured value -1) |



DIN 2276 Part 2 (Style D)

See table for max. perm. errors

LCD display according to table

Fully encapsulated measuring system with gravity pendulum

See table for max. perm. errors

2 flat measuring faces with V-slot for diameters from 20 to 120 mm

Cast iron base. Chromium plated side faces. Aluminium housing, lacquered

Response time < 3 s

Automatic shut down after 55 min

1 mV per unit (100 kΩ)

1,5 V battery, type LRC 6, AA

100 to 140 hours

≤ 0,1 %/°C based on the measuring range at 20 ± 5°C

0 to 40°C

-20 to 70°C

EN 50081-1 / -2 EN 50082-1 / -2

According to table, inclusive case

Plastic case

Identification number

Declaration of conformity



TESA NIVELTRONIC Electronic Levels with Analogue Display and Integrated Galvanometer

Electronic levels with analogue display and integrated galvanometer.

These instruments are known for a remarkable stability at zero point. They are used for the inspection and alignment of horizontal and vertical surfaces. They are also suitable for the measurement of slight inclinations, specially for the inspection of flatness of granite surface plates.

The square model is particularly suited for the measurement of flat or cylindrical parts thanks to its prismatic base.



NIVELTRONIC square model with 2 prismatic bases



NIVELTRONIC horizontal model with flat base



NIVELTRONIC horizontal with granite base

| No | = | | | | |
|----------|---|-------------|----------------|---------------|-------------|
| | | mm/m | Base length mm | Base width mm | kg |
| 03130063 | TESA NIVELTRONIC electronic level, horizontal, analogue display | 0,05 / 0,01 | 150 | 45 | 6,0 / 3,7 * |
| 03130060 | TESA NIVELTRONIC electronic level, square, analogue display | 0,05 / 0,01 | 200 | 45 | 6,5 / 4,4 * |

* With/without wooden case

OPTIONAL ACCESSORIES:

| | |
|----------|--|
| 03160007 | Granite base 200 x 50 mm for horizontal NIVELTRONIC** |
| 03160008 | Granite base 250 x 50 mm for horizontal NIVELTRONIC** |
| 03160009 | Granite base 500 x 50 mm for horizontal NIVELTRONIC** |
| 03160048 | Holder with voltage regulator (4,65 V) and 4x LR03 AAA for NIVELTRONIC |
| 04761059 | 4 batteries LR03 AAA, 1,5 V for NIVELTRONIC |

** For horizontal model

| Range | mm/m | " | mm/m |
|-------|--------|--------|------|
| 1 | ± 0,75 | ± 150" | 0,05 |
| 2 | ± 0,15 | ± 30" | 0,01 |



DIN 2276 Part 2 (Style D)



See table



See table



Inductive measuring system with gravity pendulum



As per DIN 2276: up to 0,5 * measuring range: min. 0,001 mm/m, max. 1 % of the measured value from 0,5 * measuring range: max. 1 % of (2 * measured value - 0,5 * total range.)



1 µm/m



Horizontal model with a flat measuring face. Square model with 2 flat faces having a V-slot for Ø from 20 to 120 mm



Cast iron body. Horizontal model with granite base.



≈ ± 0,2 V, impedance 4,5 kΩ



4 batteries AAA 1,5 V



10 to 30°C



-20 to 60°C



EN 50081-1 / -2 EN 50082-1 / -2



Wooden case



Identification number



Declaration of conformity



DIN 2276/1 (instrument) DIN 877 (graduation)



See table



DIN 2276/1



Mounting with 2 or 3 screws



Cardboard box



Declaration of conformity

TESA Crossed Spirit Levels – for Assembly

For the inspection and alignment of flat surfaces.

The 2 vials permit a simultaneous alignment in the X and Y axes.
The level can be screwed on to a surface.



Model B: Circular level with cross vials, 3-point mounting. Aluminium alloy protection case, anodised.

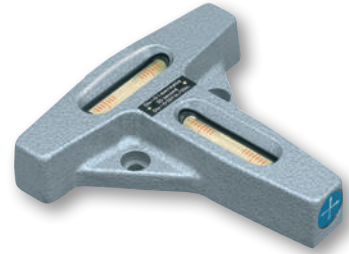

Model C: T-shaped level with cross vials, 2-point mounting. Manually lapped measuring base to ensure a much higher precision of the level.

| No | = | | A | I x L mm | ∅ mm | H mm |
|----------|--|-------|---|-------------|---------|---------|
| 05331500 | Level, 2 vials, 2 to 5 mm/m, ∅ 40 | 2 ÷ 5 | B, Circular level with 2 vials, 3x M2, 35 g (level only) | | ∅ 40 | 11 |
| 05331502 | Level, 2 vials. 0,3 mm/m, 0,3 ∅ 60 | | B, Circular level with 2 vials, 3x M4, 85g (level only) | | ∅ 60 | 13 |
| 05331550 | Level, 2 vials; 0,1 mm/m, 0,1 80 x 65 mm | | C, T-shaped level with 2 vials, 2x M5, 250 g (level only) | 80 x 65 | | 17 |
| 05331551 | Level, 2 vials; 0,3 mm/m, 0,3 80x65 mm | | C, T-shaped level with 2 vials, 2x M5, 250 g (level only) | 80 x 65 | | 17 |



TESA Precision Spirit Levels

For checking and aligning flat or cylindrical surfaces in the horizontal position.

With an adjustment system for zero point and "twist" error.

Prismatic measuring base, manually lapped finish, enabling a higher precision for the level.

Insulating grip in wood essential for reducing heat transfer due to manual handling.

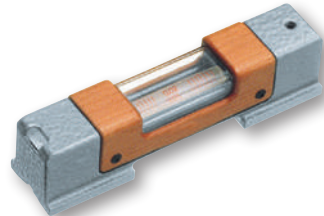

Model B: horizontal precision level

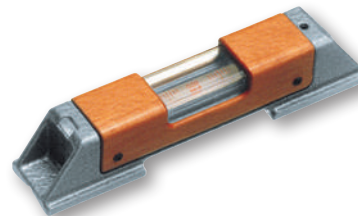

Model C: horizontal precision level

| No | = | | A | For shafts Ø, mm | mm |
|----------|---|------|-------------------------|---------------------|---------------|
| 05331050 | Precision spirit level 0,02, L = 100 mm | 0,02 | B, 0,35 kg (level only) | 17 ÷ 84 | 100 x 32 x 35 |
| 05331054 | Precision spirit level 0,02, L = 150 mm | 0,02 | B, 0,65 kg (level only) | 17 ÷ 94 | 150 x 35 x 38 |
| 05331058 | Precision spirit level 0,02, L = 200 mm | 0,02 | C, 0,95 kg (level only) | 19 ÷ 108 | 200 x 40 x 42 |
| 05331061 | Precision spirit level 0,1, L = 200 mm | 0,1 | C, 0,95 kg (level only) | 19 ÷ 108 | 200 x 40 x 42 |
| 05331063 | Precision spirit level 0,02, L = 250 mm | 0,02 | C, 1,3 kg (level only) | 19 ÷ 120 | 250 x 45 x 42 |

TESA Precision Spirit Levels with a Frame

For checking and aligning flat or cylindrical surfaces in horizontal and vertical positions.

Instrument features: 4 measuring faces, 2 prismatic faces (shafts Ø 17 to 135 mm) et 2 smooth flat faces.

With adjustment system for zero point and "twist" error.

Longitudinal vial with sensitivity of 0,02 to 0,1 mm/m, depending on the model.

Side viewing slots for an excellent visibility of the top and side of the main vial.

Cross vial with sensitivity of 2-5 mm/m for easy adjustment.

3 insulating grips to avoid any thermal transfer.

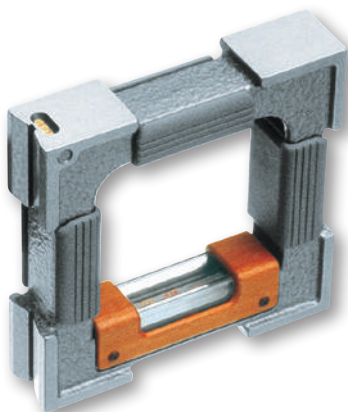

| No | = | | For shafts Ø, mm | mm |
|----------|---|------|---------------------|----------------|
| 05331201 | Precision spirit level with frame, 0,05/100 x 100 x 32 mm | 0,05 | 17 ÷ 84 | 100 x 100 x 32 |
| 05331202 | Precision spirit level with frame, 0,1/100 x 100 x 32 mm | 0,1 | 17 ÷ 84 | 100 x 100 x 32 |
| 05331204 | Precision spirit level with frame, 0,05/150 x 150 x 35 mm | 0,05 | 17 ÷ 94 | 150 x 150 x 35 |
| 05331206 | Precision spirit level with frame, 0,02/200 x 200 x 40 mm | 0,02 | 19 ÷ 108 | 200 x 200 x 40 |
| 05331210 | Precision spirit level with frame, 0,05/250 x 250 x 45 mm | 0,05 | 19 ÷ 120 | 250 x 250 x 45 |

- TESA
- DIN 877
- See table
- DIN 2276 Part 1
- Flat and prismatic measuring faces
- Longitudinal and cross level vials
- Wooden case
- Declaration of conformity

- TESA
- DIN 877
- See table
- DIN 2276 Part 1
- 4 x 90° flat measuring faces, machined together, 2 of them with V-shape grooves
- Longitudinal and cross vials
- Wooden case
- Declaration of conformity

- TESA
- DIN 877
- See table
- DIN 2276 Part 1
- Two flat measuring faces machined as a set (90°), v-shaped groove
- Longitudinal and cross vials
- Wooden case
- Declaration of conformity

TESA Precision Spirit Levels, Square Models with Magnetic Inserts

For inspecting and aligning flat or cylindrical surfaces in horizontal and vertical positions.

Instrument features: 2 prismatic faces (shafts \varnothing 19 to 108 mm) with the vertical measuring face having magnetic inserts.

Equipped with an adjustment system for zero point and "twist" error.

Longitudinal vial with a sensitivity from 0,02 to 0,05 mm/m, depending on the model.

Cross vial with a sensitivity of 2-5 mm/m for an easy adjustment.

A quality wooden grip reduces thermal transfer during manual handling.

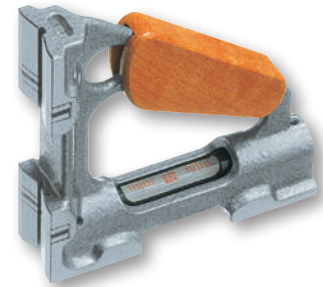

| No | = | | | |
|----------|---|------|-------------------------------|----------------|
| | | mm/m | For shafts \varnothing , mm | mm |
| 05331000 | Magnetic square level 0,02/150 x 150 x 40 mm | 0,02 | 19 ÷ 108 | 150 x 150 x 40 |
| 05331002 | Magnetic square level 0,05/150 x 150 x 40 mm | 0,05 | 19 ÷ 108 | 150 x 150 x 40 |

TESA Precision Spirit Level with Micrometric Adjustment

Precision spirit level with micrometer adjustment.

For the measurement of inclinations from -20 to +4 mm/m.

1 division = 0,02 mm/m

Instrument features:

+ 1 micrometer rotation = + 2 mm/m (100 divisions)

+ 2 micrometer rotations = + 4 mm/m

- 10 micrometer rotations = - 20 mm/m

Prismatic measuring face (shafts \varnothing 19 to 120 mm).

Longitudinal vial with sensitivity of 0,02 mm/m

Cross vial with sensitivity of 2-5 mm/m for easy horizontal adjustment.

With side thermal insulators to reduce heat transfers to the instrument during manual handling.



| No | = | | | |
|----------|--|------|-------------------------------|---------------|
| | | mm/m | For shafts \varnothing , mm | mm |
| 05331450 | Precision spirit level with micrometer element 0,02 / 150 x 45 x 45 mm | 0,02 | 19 ÷ 120 | 150 x 45 x 45 |

- TESA
- DIN 877
- DIN 2276 Part 1
- Flat measuring faces with v-shaped grooves
- Hardened and ground steel
- Longitudinal and cross vials
- Wooden case
- Declaration of conformity



TESA Spirit Inclinometer with Protractor and Micrometer Element

Enables the measurement of angular deviations in any position of a cylindrical or flat surface.

Instrument features: prismatic measuring face (shafts \varnothing 17 to 80 mm) (DIN 877 + DIN 2276/1). Scale range: $2 \times 180^\circ$.

The adjustment is executed by disengaging the micrometer element by pressing in the direction indicated by the arrow. Afterwards the vial is oriented manually before engaging the micrometer element and executing the fine adjustment with the latter.

1 scale division = 1 degree.

1 division of the micrometer element = 1 Arcmin

Vial with sensitivity of 0,3 mm/m (= 1 Arcmin).

Error limit = 1,5 Arcmin

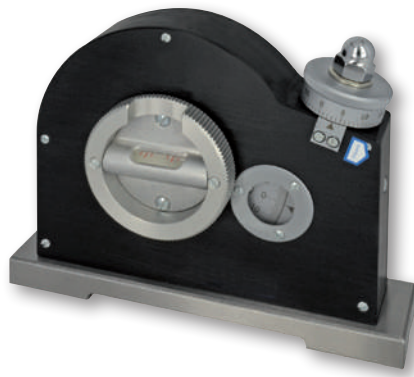

DIN 877



DIN 2276 part 1



Flat measuring faces with v-shaped groove



Hardened and ground steel base



Longitudinal and cross vials



Wooden case



Declaration of conformity



Scale division of micrometer element

1 Arcmin



Scale division of level

1 Arcmin (0,30 mm/m)



$2 \times 180^\circ$



For shafts \varnothing , mm

17 ÷ 80



mm

150 x 35 x 116

05331750

Spirit clinometer with angle protractor and micrometer element



Accessories for Clinometers and Levels



| | |
|-----------------|---|
| 04768002 | 4 batteries LRC 6 AA, 1,5 V for CLINOBEVEL 1 USB, CLINOBEVEL 2, MICROBEVEL, |
| 05360006 | External switch with cable, L = 2 m, for CLINOBEVEL 1 USB |
| 05360014 | External switch, wireless, for CLINOBEVEL 1 USB |
| 05360004 | Connecting cable between 2 CLINOBEVEL 2, L = 2,5 m |
| 04761059 | 4 batteries LR03 AAA, 1,5 V for NIVELTRONIC |
| 03160007 | Granite base 200 x 50 mm for horizontal NIVELTRONIC |
| 03160008 | Granite base 250 x 50 mm for horizontal NIVELTRONIC |
| 03160009 | Granite base 500 x 50 mm for horizontal NIVELTRONIC |
| 03160048 | Holder with voltage regulator (4,65 V) and 4x LR03 AAA for NIVELTRONIC |



FLATNESS MEASUREMENT

ROCH Bevelled Straight Edges

Models with 1 bevelled edge, with insulating grip to limit the transfer of thermal heat during manual handling for optimal precision.



Bevelled edge

| No | = | Accuracy | |
|------------|------------------------|----------|-----|
| | | μm | mm |
| 0951750002 | Bevelled straight edge | 2 | 75 |
| 0951750003 | Bevelled straight edge | 2 | 100 |
| 0951750005 | Bevelled straight edge | 3 | 150 |
| 0951750006 | Bevelled straight edge | 3 | 200 |
| 0951750007 | Bevelled straight edge | 3 | 300 |



DIN 874 T2, NFE 11-104



Hardened steel to ≥ 650 HV 10



Straight edges up to 200 mm in a plastic case, ≥ 300 mm in a wooden case.



Declaration of conformity

SQUARES

ROCH Flat and Try Squares in Steel – Accuracy Class 1

Try square 90° flat in stainless steel, non-hardened



| No | = | Accuracy | | Length of beams, mm | Section mm |
|------------|------------------|----------|----------------|---------------------|------------|
| | | μm | Accuracy Class | | |
| 0951751605 | Try-square steel | 15 | With 90° hook | 100 x 70 | 20 x 5 |
| 0951751607 | Try-square steel | 18 | With 90° hook | 150 x 100 | 28 x 6 |



Factory standard



Accuracy class 1



Accuracy class 1



Stainless steel, hardness 200 HRB,



Transport packing



Declaration of conformity





N Factory standard

Hardened steel

Plastic case

Brown & Sharpe Try Square Set

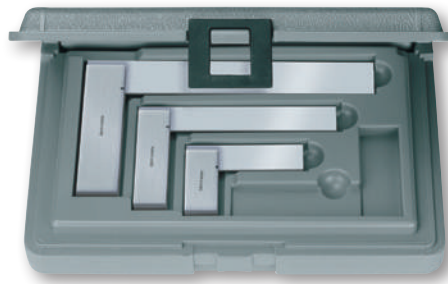

No

=

06739001 Three square set B & S

=



Consisting of:

mm

µm

1 Try square

68 x 45

16

1 Try square

120 x 70

16

1 Try square

175 x 95

16



N DIN 875 NFE 11-103

Accuracy class 00

Accuracy class 00

Accuracy class 00

Stainless steel,
hardened to
≥ 550 HV 30

Transport packing

Declaration of
conformity

ROCH Bevelled Edge Squares – Accuracy Class 00

Bevelled edge 90° squares in stainless steel, hardened



No

=



µm

Length of
beams, mm

Section of
beams
mm

0951751533 Bevelled edge square, stainless

3

50 x 40

14 x 4,5

0951751534 Bevelled edge square, stainless

3

75 x 50

16 x 4

0951751535 Bevelled edge square, stainless

3

100 x 70

20 x 5



ANGLE PROTRACTORS

Angle Protractor with Digital Display

Measuring ranges 1x 360°, 2x 180°, 4x 90°

Large decimal or sexagesimal display

2 measuring directions

Fine setting with adjustment screw

Locking system

Scale L = 200 mm (300 or 500 mm available as options)

RS232 data output

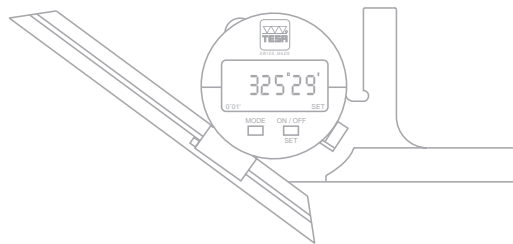

00630010 Angle protractor with digital display. Supplied with a scale of L = 200 mm

OPTIONAL ACCESSORIES:

00660004 Scale 200 mm

00660005 Scale 300 mm

00660006 Scale 500 mm

00660007 Supporting base with 1 flat measuring face and 1 prismatic measuring face

00660008 Square for measuring sharp angles

01961000 Lithium battery, 3V, CR 2032

04761062 Opto-USB cable, duplex, bidirectional communication



Measuring ranges:
1 x 360°, 2 x 180°,
4 x 90°



LCD, 5 digits + sign



0,01° / 1 minute
of arc



8,5 mm



Max. perm. error.: 4
minutes of arc



Stainless steel body,
hardened



Maximum rotation
speed.: 1080°/s



Preset to 0° or 180°



RS232 opto-coupled



1x CR2032 3,0 V



5000 hours



+5°C to + 40°C



IP51 (CEI 529)



410 g



Wooden case (ISPM
15 andt NIPM 15)



Identification
number

Declaration of
conformity





2 circular scales



Main scale: 5'.
Double numbering in opposite directions.
Auxiliary scale: 10°



Max. perm. error: 5' (without accessory)



Hardened stainless steel



Plastic case



Declaration of conformity

EAC Angle Protractor with Dial

Circular scale with needle pointer
Easy reading on main and auxiliary scales
Very low hysteresis
Precision movement with compensation for mechanical play.

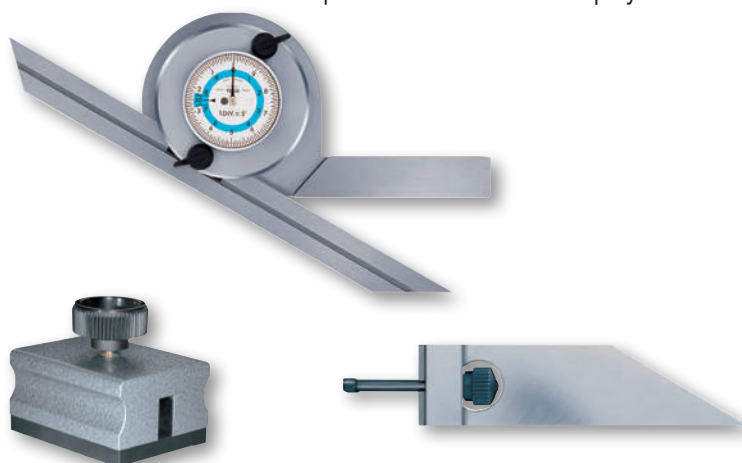

00610102

00610101

| No | = | | |
|-----------------------|--|---------|-----|
| 00630001 | EAC angle protractor with dial | 4 x 90° | 200 |
| 00630002 | EAC angle protractor with dial | 4 x 90° | 300 |
| OPTIONAL ACCESSORIES: | | | |
| 00660002 | Scale | | 200 |
| 00660003 | Scale | | 300 |
| 00610102 | Cast iron base with steel bottom surface, hardened | | |



5'



Max. perm. error: 5' (without accessory)



Stainless steel, hardened



Plastic case



Declaration of conformity

ETALON Angle Protractor with Vernier Scale



| No | = | | | |
|-----------------------|--|---------|----|-----|
| 076115566 | ETALON angle protractor with vernier 200 mm | 4 x 90° | No | 200 |
| 076115567 | ETALON angle protractor with vernier 300 mm | 4 x 90° | No | 300 |
| OPTIONAL ACCESSORIES: | | | | |
| 00660002 | Scale | | | 200 |
| 00660003 | Scale | | | 300 |
| 00610102 | Cast iron base with steel bottom surface, hardened | | | |



Brown & Sharpe Angle Protractor - Multiple Combinations

This angle protractor combination set can be used as a scale, depth gauge, try square, centering tool, marker or even as a spirit level.

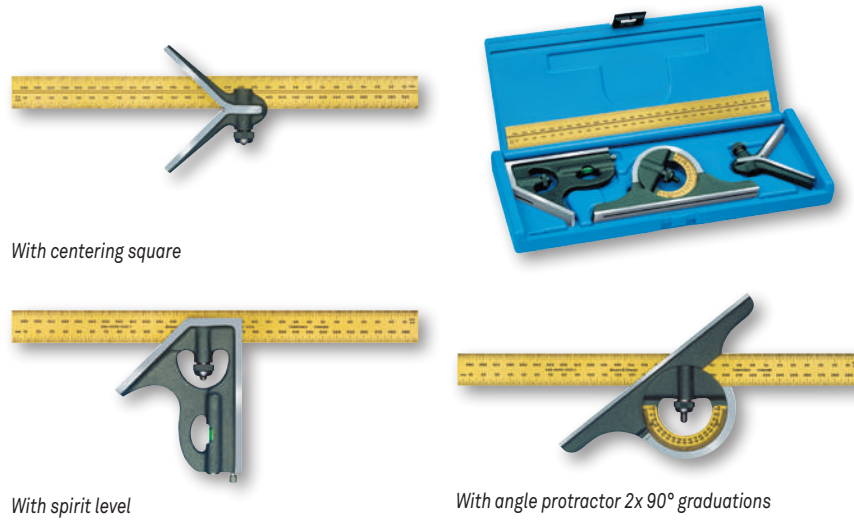

- Hardened steel. Measuring faces specially treated against scratches
- Pastic case

| | | | |
|----------|---|--|---|
| | | | Consisting of: |
| 06719000 | B&S angle protractor set with multiple combinations | | <ul style="list-style-type: none"> - 1 Ruler graduated in millimetres, length 300 mm - 1 Angle protractor with 2 x 90° graduations - 1 Centering square - 1 Square head with scribe |

Brown & Sharpe Sine Bar

Suited for setting ranges from 0 to 60°
Sine function for establishing the angle that needs to be set on the basis of the length dimensions obtained from parallel gauge blocks.

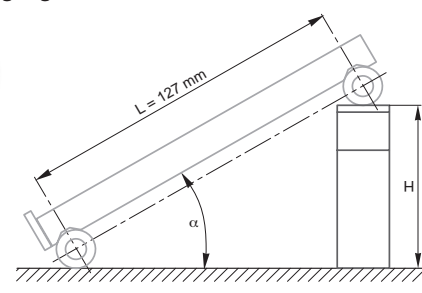
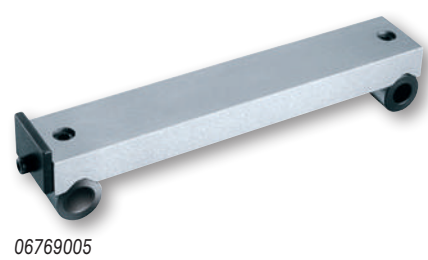

Example for the calculation of an angle
 Given: H = height of combination gauge blocks in mm
 L = length of B&S sine bar in mm
 Formula: $H = L \cdot \sin(\alpha)$
 $\sin(\alpha) = H/L$
 angle = arcsin (H/L)
 Calculation for determining angle knowing H et L values:
 angle = arcsin (89,803 / 127) = arcsin (0,70711) = 45°

- 5 µm
- Hardened alloy steel
- Removable front stop
- Cardboard box
- Declaration of conformity

| | | | | |
|----------|--------------|-------------|----------|-------------------------|
| | | | | L (centre distance), mm |
| 06769005 | B&S Sine bar | 127 ± 0,004 | 123 x 25 | |

Length and Angle Standards

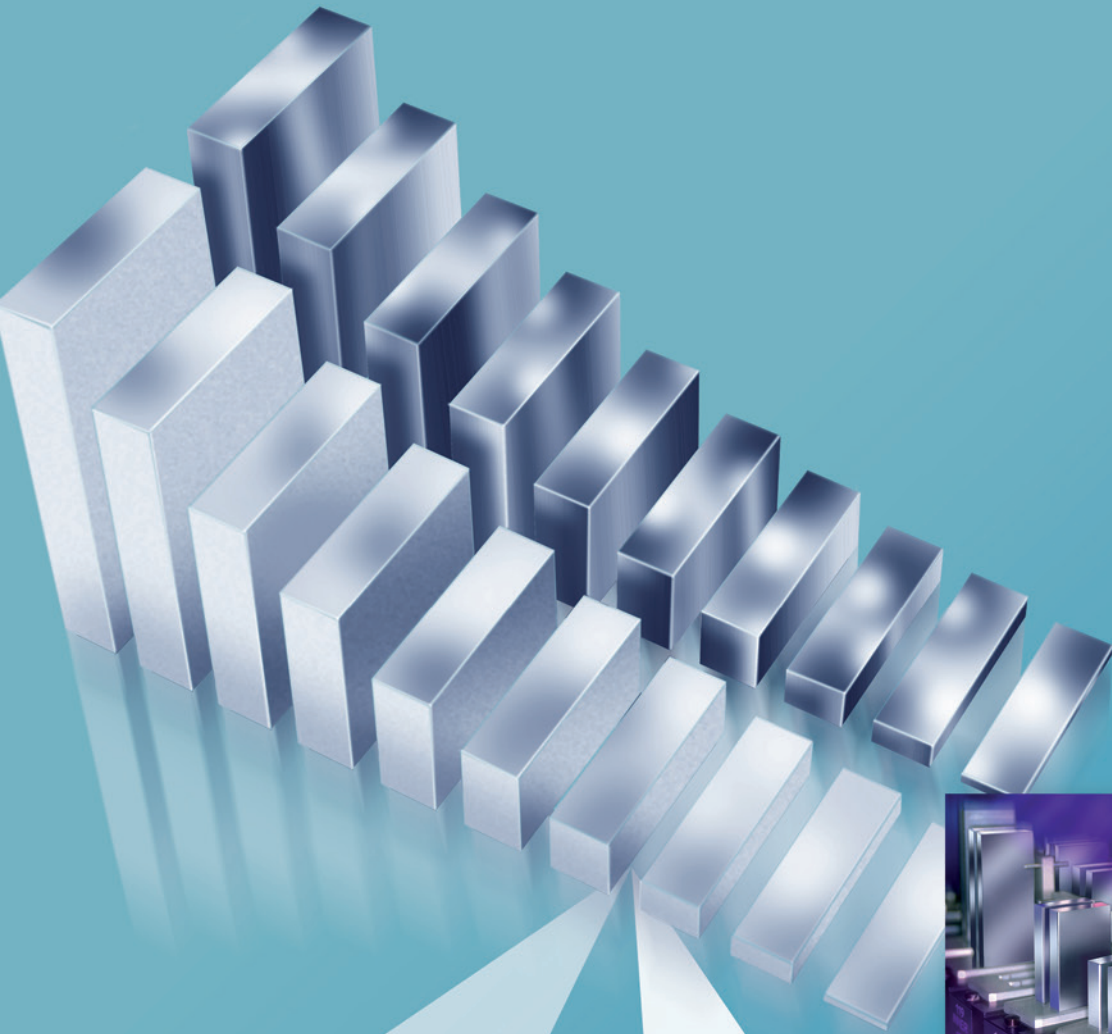

PURCHASING GAUGE BLOCKS CALLS FOR CONFIDENCE

The high accuracy of TESA's gauge blocks is the result of years of experience in producing and making use of these products.

- Use of high quality raw materials and appropriate heat treatment, thus guaranteeing a durable shape and dimensional stability of the gauge blocks over years.
- Very low deviations in flatness and parallelism of the measuring faces, resulting in highly accurate gauges.
- Unique flat lapping polish as well as edge rounding techniques, leading to superior wringability.
- Proper serial number marked on each gauge block.

ISO 3650

Gauge blocks with metric nominal lengths conform to ISO 3650:1998. This international standard is based on the ones published either in a region, e.g. the European standard EN ISO 3650:1998 or in a country, e.g. the Swiss standard SN EN ISO 3650, German standard DIN EN ISO 3650 or French standard NF EN ISO 3650. Gauge blocks with imperial nominal lengths comply with BS 4311 - Part 1. Compared to earlier standards, ISO 3650:1998 includes the following main changes :

- Withdrawal of the accuracy grade 00 (see "Which grade do you need").
- Introduction of requirements as regards the uncertainty of measurement in relation to the declaration of conformance of the product according to ISO 14253-1:1998.
- Review of some definitions and shortened form of terms according to normative references that are currently applicable (see drawing).

WHICH MATERIAL DO YOU NEED?

Steel

Steel gauge blocks have proven their reliability for more than a hundred years. This raw material remains the most commonly accepted for length standards.

- Steel gauge blocks provide high resistance to wear associated with a good property to adhere to other gauge blocks. However, steel must be protected against corrosion. Provided gauge blocks made from this material are properly handled, they will remain reliable for many years. TESA steel gauge blocks have the following key features:
- Highly alloyed steel
- Hardness guaranteed to 800 HV
- Artificially aged for optimum form and dimensional stability
- Coefficient of thermal expansion: $(11,5 \pm 1,0) \times 10^{-6} K^{-1}$

Tungsten Carbide

Gauge blocks in tungsten carbide are 10 times as resistant to wear as steel gauges. They are intended for frequent use, also where superior wringing quality is required. TESA tungsten carbide gauge blocks provide:

- Hardness guaranteed to 1400 HV
- Coefficient of thermal expansion: $(4,23 \pm 0,1) \times 10^{-6} K^{-1}$

Ceramic

Ceramic gauge blocks are extremely resistant to wear and scratches. Due to the properties of this material, any minor damage is unlikely to affect the wringability of their measuring faces. Being corrosion resistant, these gauge blocks are insensitive to "rusty hands", amongst other issues. Manufactured from stabilised zirconia, TESA ceramic gauge blocks have the following key features:

- Non-magnetizable
- Hardness guaranteed to 1400 HV
- Coefficient of thermal expansion: $(9,7 \pm 0,8) \times 10^{-6} K^{-1}$



WHICH GRADE DO YOU NEED?

Grade 2

These gauge blocks are commonly used as **Working Standards** in inspection rooms within a manufacturing area to set and calibrate measuring instruments and other equipment as well as to inspect tools, fixtures and machines.

Grade 1

Gauge blocks of this class are mainly used as **Working Standards** to set and calibrate plug gauges and measuring instruments in measuring rooms or inspection areas within a manufacturing area.

Tolerance Grade 0

These gauge blocks are designated for use as **Company Standards** in calibration laboratories or environmentally controlled inspection rooms to set and calibrate plug gauges as well as measuring equipment.

Calibration grade K

Gauge blocks of this tolerance class are intended for use as **Reference Standards** in metrology oriented laboratories of National Institutes, precision measuring rooms and other laboratories of National Calibration Services, whether officially accredited or not.

They should be used as masters to calibrate gauge blocks, length standards of same accuracy and also measuring instruments.

Precision Grade 00

The new standard ISO 3650 no longer takes this accuracy grade into consideration as the uncertainties of measurement achieved with the procedure applied for calibration usually lead to a disparity against specified tolerances.

The rules to the expression of uncertainty of measurement for proving the conformance or non conformance of the product with the specification, as stated in the standard ISO 14253- 1:1998, have dictated the decision to withdraw the accuracy grade 00.

A wide experience in practical use of gauge blocks has proven that gauges of the calibration class K could easily replace those of the earlier accuracy grade 00.

As a result, gauge blocks of grade 00 are no longer available.

CERTIFICATE OF CALIBRATION AND TRACEABILITY.

All set compositions from TESA are supplied with a certificate of calibration issued by the accredited calibration laboratory of a national calibration service.

This service can either be the Swiss calibration service (SCS), British calibration service (UKAS) or Deutsche Akkreditierungsstelle (DAkkS) depending on the manufacturer.

Accreditation is the authenticated assurance of the skills of the calibration laboratories as well as of the full traceability to national standards that conform with the International System of Units (SI).

This is for any reference standard or measuring equipment being used.

Owing to a multilateral agreement (MLA), any certificates of calibration issued by the members of the European Cooperation for Accreditation of Laboratories (EA) is internationally accepted.

DELIVERIES

TESA gauge blocks can be delivered individually or in full sets with nominal lengths as listed in this section. Additional gauge sets and lengths can be made available upon request. Since individual gauge blocks could not be listed in their whole here, any inquiry or purchase order should specify :

- Desired nominal length
- Chosen material
- Calibration grade or any other grade



Limit Deviations and Tolerances

| | | | | |
|-----------------------|-------------------------------------|---------------|---------------|---------------|
| | Limit deviations t_e | | | |
| | Tolerances t_v | | | |
| | Flatness tolerances t_f | | | |
| Nominal length | Calibration grades and other grades | | | |
| | K | 0 | 1 | 2 |
| | Flatness tolerance t_f | | | |
| mm | μm | μm | μm | μm |
| $0,5 = l_n \leq 150$ | 0,05 | 0,1 | 0,15 | 0,25 |
| $150 < l_n \leq 500$ | 0,1 | 0,15 | 0,18 | 0,25 |
| $500 < l_n \leq 1000$ | 0,15 | 0,18 | 0,2 | 0,25 |

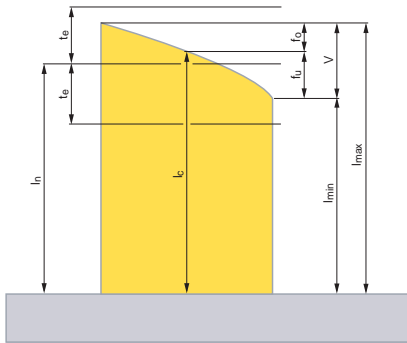

Nominal length l_n ; Central length l_c ; Variation v with f_0 and f_1 ; Limit deviations t_e at any point proceeding from the nominal length.

| Nominal length | Calibration grade K | | Grade 0 | | Grade 1 | | Grade 2 | |
|----------------|--|---------------------------------------|--|---------------------------------------|--|---------------------------------------|--|---------------------------------------|
| | Limit deviation of length at any point from nominal length | Tolerance for the variation in length | Limit deviation of length at any point from nominal length | Tolerance for the variation in length | Limit deviation of length at any point from nominal length | Tolerance for the variation in length | Limit deviation of length at any point from nominal length | Tolerance for the variation in length |

LIMIT DEVIATIONS AND TOLERANCES ACCORDING TO ISO 3650

| mm | $\pm t_e$ μm | t_v μm | $\pm t_e$ μm | t_v μm | $\pm t_e$ μm | t_v μm | $\pm t_e$ μm | t_v μm |
|-----------------------|----------------------------|------------------------|----------------------------|------------------------|----------------------------|------------------------|----------------------------|------------------------|
| $0,5 = l_n \leq 10$ | 0,2 | 0,05 | 0,12 | 0,1 | 0,2 | 0,16 | 0,45 | 0,3 |
| $10 < l_n \leq 25$ | 0,3 | 0,05 | 0,14 | 0,1 | 0,3 | 0,16 | 0,6 | 0,3 |
| $25 < l_n \leq 50$ | 0,4 | 0,06 | 0,2 | 0,1 | 0,4 | 0,18 | 0,8 | 0,3 |
| $50 < l_n \leq 75$ | 0,5 | 0,06 | 0,25 | 0,12 | 0,5 | 0,18 | 1,0 | 0,35 |
| $75 < l_n \leq 100$ | 0,6 | 0,07 | 0,3 | 0,12 | 0,6 | 0,2 | 1,2 | 0,35 |
| $100 < l_n \leq 150$ | 0,8 | 0,08 | 0,4 | 0,14 | 0,8 | 0,2 | 1,6 | 0,4 |
| $150 < l_n \leq 200$ | 1,0 | 0,09 | 0,5 | 0,16 | 1,0 | 0,25 | 2,0 | 0,4 |
| $200 < l_n \leq 250$ | 1,2 | 0,1 | 0,6 | 0,16 | 1,2 | 0,25 | 2,4 | 0,45 |
| $250 < l_n \leq 300$ | 1,4 | 0,1 | 0,7 | 0,18 | 1,4 | 0,25 | 2,8 | 0,5 |
| $300 < l_n \leq 400$ | 1,8 | 0,12 | 0,9 | 0,2 | 1,8 | 0,3 | 3,6 | 0,5 |
| $400 < l_n \leq 500$ | 2,2 | 0,14 | 1,1 | 0,25 | 2,2 | 0,35 | 4,4 | 0,6 |
| $500 < l_n \leq 600$ | 2,6 | 0,16 | 1,3 | 0,25 | 2,6 | 0,40 | 5,0 | 0,7 |
| $600 < l_n \leq 700$ | 3,0 | 0,18 | 1,5 | 0,3 | 3,0 | 0,45 | 6,0 | 0,7 |
| $700 < l_n \leq 850$ | 3,4 | 0,2 | 1,7 | 0,3 | 3,4 | 0,5 | 6,5 | 0,8 |
| $800 < l_n \leq 900$ | 3,8 | 0,2 | 1,9 | 0,35 | 3,8 | 0,5 | 7,5 | 0,9 |
| $900 < l_n \leq 1000$ | 4,2 | 0,25 | 2,0 | 0,4 | 4,2 | 0,6 | 8,0 | 1,0 |

LIMIT DEVIATIONS AND TOLERANCES ACCORDING TO BS 4311, PART 1:1993

| in | $\pm t_e$ μin | t_v μin | $\pm t_e$ μin | t_v μin | $\pm t_e$ μin | t_v μin | $\pm t_e$ μin | t_v μin |
|--------------------|-----------------------------|-------------------------|-----------------------------|-------------------------|-----------------------------|-------------------------|-----------------------------|-------------------------|
| $l_n \leq 0,4$ | 5 | 2 | 5 | 4 | 10 | 6 | 20 | 12 |
| $0,4 < l_n \leq 1$ | 6 | 2 | 6 | 4 | 12 | 6 | 25 | 12 |
| $1 < l_n \leq 1$ | 8 | 3 | 8 | 4 | 15 | 7 | 30 | 12 |
| $2 < l_n \leq 3$ | 10 | 3 | 10 | 5 | 20 | 7 | 40 | 14 |
| $3 < l_n \leq 4$ | 12 | 3 | 12 | 5 | 25 | 8 | 50 | 14 |

LIMIT DEVIATIONS AND TOLERANCES ACCORDING TO FACTORY STANDARD FOR GAUGE BLOCKS OVER 4 IN

| in | $\pm t_e$ μin | t_v μin | $\pm t_e$ μin | t_v μin | $\pm t_e$ μin | t_v μin | $\pm t_e$ μin | t_v μin |
|--------------------|-----------------------------|-------------------------|-----------------------------|-------------------------|-----------------------------|-------------------------|-----------------------------|-------------------------|
| $4 < l_n \leq 6$ | 31 | 3 | 15 | 5 | 31 | 8 | 63 | 16 |
| $6 < l_n \leq 8$ | 40 | 3 | 20 | 6 | 40 | 10 | 79 | 16 |
| $8 < l_n \leq 10$ | 47 | 4 | 23 | 6 | 47 | 10 | 95 | 18 |
| $10 < l_n \leq 12$ | 55 | 4 | 28 | 7 | 55 | 10 | 110 | 20 |
| $12 < l_n \leq 16$ | 70 | 5 | 35 | 8 | 70 | 12 | 140 | 20 |
| $16 < l_n \leq 20$ | 87 | 5 | 43 | 10 | 87 | 14 | 174 | 24 |



GAUGE BLOCKS

Gauge Block Set M32, M47, M88, M112 and M122.

Nominal lengths 1 ÷ 100 mm in steel, carbide or ceramic.

Grades K, 0, 1 and 2 available in all sets. Steel gauges to all grades with DAkkS certificate. Carbide or ceramic gauges to all grades with UKAS certificate.



ISO 3650

Limit deviations t_v , see Table

Tolerances t_s , see Table

see Table

Steel: highly alloyed, wear resistant.
Tungsten carbide: wear resistant and stable.
Ceramic: stabilised zirconia, extremely resistant to wear and scratches

Steel: $(11,5 \pm 1,0) \times 10^{-6} K^{-1}$
Tungsten carbide: $(4,23 \pm 0,1) \times 10^{-6} K^{-1}$
Ceramic: $(9,7 \pm 0,8) \times 10^{-6} K^{-1}$

Supplied individually or in sets

Wooden case

Identification number

Steel gauges to all grades with DAkkS certificate. Carbide or ceramic gauges to all grades with UKAS certificate

TESA Gauge Block Set M32, Metric

| No | | Grade |
|------------|-------|-------|
| 0651516027 | Steel | K |
| 0651515027 | Steel | 0 |
| 0651511027 | Steel | 1 |
| 0651512028 | Steel | 2 |

Set compositions

| mm | Steps, mm | Pieces |
|----------------|-----------|--------|
| 1,005 | – | 1 |
| 1,01 ÷ 1,09 | 0,01 | 9 |
| 1,1 ÷ 1,9 | 0,1 | 9 |
| 1,0 ÷ 9,0 | 1,0 | 9 |
| 10, 20, 30, 60 | – | 4 |

TESA Gauge Block Set M47, Metric

| No | | Grade |
|------------|-------|-------|
| 0651516021 | Steel | K |
| 0651515021 | Steel | 0 |
| 0651511021 | Steel | 1 |
| 0651512021 | Steel | 2 |

Set compositions

| mm | Steps, mm | Pieces |
|-------------|-----------|--------|
| 1,005 | – | 1 |
| 1,01 ÷ 1,09 | 0,01 | 9 |
| 1,1 ÷ 1,9 | 0,1 | 9 |
| 1,0 ÷ 24,0 | 1,0 | 24 |
| 25 ÷ 100 | 25 | 4 |

TESA Gauge Block Set M88, Metric

| No | | Grade |
|------------|-------|-------|
| 0651516014 | Steel | K |
| 0651515014 | Steel | 0 |
| 0651511014 | Steel | 1 |
| 0651512014 | Steel | 2 |

Set compositions

| mm | Steps, mm | Pieces |
|---------------|-----------|--------|
| 1,0005 | – | 1 |
| 1,001 ÷ 1,009 | 0,001 | 9 |
| 1,01 ÷ 1,49 | 0,01 | 49 |
| 0,5 ÷ 9,5 | 0,5 | 19 |
| 10 ÷ 100 | 10 | 10 |



TESA Gauge Block Set M112, Metric

| No | | Grade |
|------------|-------|-------|
| 0651516012 | Steel | K |
| 0651515012 | Steel | 0 |
| 0651511012 | Steel | 1 |
| 0651512012 | Steel | 2 |

Set compositions

| mm | Steps, mm | Pieces |
|---------------|-----------|--------|
| 1,0005 | – | 1 |
| 1,001 ÷ 1,009 | 0,001 | 9 |
| 1,01 ÷ 1,49 | 0,01 | 49 |
| 0,5 ÷ 24,5 | 0,5 | 49 |
| 25 ÷ 100 | 25 | 4 |

TESA Gauge Block Set M122, Metric

| No | | Grade |
|------------|-------|-------|
| 0651516011 | Steel | K |
| 0651515011 | Steel | 0 |
| 0651511011 | Steel | 1 |
| 0651512011 | Steel | 2 |

Set compositions

| mm | Steps, mm | Pieces |
|---------------|-----------|--------|
| 1,0005 | – | 1 |
| 1,001 ÷ 1,009 | 0,001 | 9 |
| 1,01 ÷ 1,49 | 0,01 | 49 |
| 1,6 ÷ 1,9 | 0,1 | 4 |
| 0,5 ÷ 24,5 | 0,5 | 49 |
| 30 ÷ 100 | 10 | 8 |
| 25,75 | – | 2 |



Special Versions

Available on request :

- Tungsten carbide gauge block set
- Ceramic gauge block set
- TESA maintenance kit



ISO 3650

Limit deviations t_s , see Table

Tolerances t_v , see Table

see Table

Steel: highly alloyed, wear resistant.
Tungsten carbide: wear resistant and stable.
Ceramic: stabilised zirconia, extremely resistant to wear and scratches

Steel: $(11,5 \pm 1,0) \times 10^{-6} K^{-1}$
Tungsten carbide: $(4,23 \pm 0,1) \times 10^{-6} K^{-1}$
Ceramic: $(9,7 \pm 0,8) \times 10^{-6} K^{-1}$

Supplied individually or in sets

Wooden case

Identification number

Steel gauges to all grades with DAkkS certificate.
Carbide or ceramic gauges to all grades with UKAS certificate





Diameter and thickness as shown in table

Optical flats with 2 flat measuring faces. No guaranty can be given for parallelism.

Wooden case

Declaration of conformity

ACCESSORIES FOR GAUGE BLOCKS

The interference lenses allow visual inspection of the surface of the gauge blocks.

TESA Optical Flats

Used for examining flatness and adhesion of gauge blocks or any other test pieces having flat faces with same high grade of accuracy.

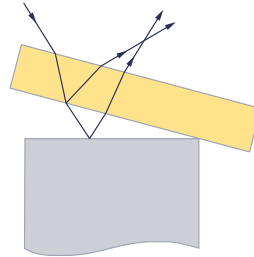

| No | ∅ | Thickness, mm | μm |
|----------|----|---------------|-------|
| 02530050 | 50 | 15 | 0,125 |
| 02530075 | 75 | 20 | 0,125 |

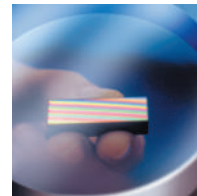

Light source: 35 W sodium lamp, 89% monochromatic, colour yellow, wavelength 0,575 μm

Surface plate: 0,5 μm

Surface plate: 2,5 μm

406 x 406 x 355 mm (W x D x H)

Surface plate in hardened steel

Case in lacquered wood

See table

Suited carrying case

TESA Monochromatic Light Unit

For use with optical flats or optical parallels to measure both the flatness and parallelism of the measuring faces by interferometry.

Monochromatic light source providing high-contrast interference fringes.

This light unit uses a single wavelength so that bright/light fringes only are visible.

The light source at the rear of the case also permits a visual examination, e.g. with the aid of a knife-edge or bevelled straight edge.

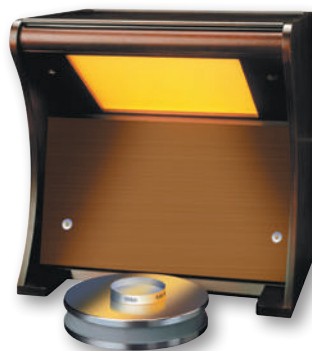

| No | = | V |
|------------------------------|---|-----------|
| 0652500422 | Universal monochromatic light | 210 ÷ 230 |
| STANDARD ACCESSORIES: | | |
| 0651570269 | 200 mm dia. surface plate, lapped and polished measuring face | |
| 0652500424 | Sodium light bulb (spare lamp) | |



Brown & Sharpe Angle Gauges

For setting and calibration purposes – Smallest step to 15' (1/4°).

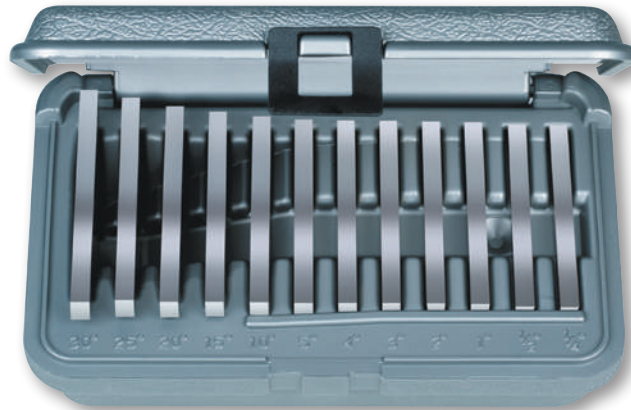

Width:
6,35 mm (1/4 in)
Length:
≥ 76,2 mm (3 in)



06769002 Precision angle block set

Set Composition

15' / 30' / 1° / 2° / 3° / 4° / 5° /
10° / 15° / 20° / 25° / 30°

Steel Balls – Brown & Sharpe Steel Balls

Steel balls are used to measure internal tapers and similar.



06769009 Steel ball set

1 ÷ 25

1

Pieces by Nominal Ø /total
pieces
2 / 50



PLUG AND RING GAUGES

The high-precision plug gauges (rods CARY) are specially adapted to inspect small diameters from 0,05 mm to 10 mm.

The ring gauges allow to inspect cylindrical parts such as pivots and spline shafts, diameters from 0,06 mm to 30 mm.

TESA CARY Plug Gauges, Diameters 0,050 to 0,300 mm – Type TDH

Due to their small size, these plug gauges are best handled using tweezers.

- EN ISO 1938
- Steel
- Accuracy: STANDARD (blue handle) $\pm 0,4 \mu\text{m}$. ETALON (yellow handle) $\pm 0,15 \mu\text{m}$
- Light alloy, coloured handle with engraved nominal diameter
- Inspection report available on request



| No | | | |
|---------|------------------------|--------------------|---------------------|
| | μm | mm | Step, μm |
| CJ1D1S2 | $\pm 0,4 \mu\text{m}$ | $0,050 \div 0,080$ | 2 |
| CJ1D2S2 | $\pm 0,4 \mu\text{m}$ | $0,081 \div 0,309$ | 2 |
| CJ1D1S0 | $\pm 0,4 \mu\text{m}$ | $0,050 \div 0,080$ | 1 |
| CJ1D2S0 | $\pm 0,4 \mu\text{m}$ | $0,081 \div 0,309$ | 1 |
| CJ1D1E2 | $\pm 0,15 \mu\text{m}$ | $0,050 \div 0,080$ | 2 |
| CJ1D2E2 | $\pm 0,15 \mu\text{m}$ | $0,081 \div 0,309$ | 2 |
| CJ1D1E0 | $\pm 0,15 \mu\text{m}$ | $0,050 \div 0,080$ | 1 |
| CJ1D2E0 | $\pm 0,15 \mu\text{m}$ | $0,081 \div 0,309$ | 1 |

OPTIONAL ACCESSORIES:

- CJ1ED25N Wooden case for 25 TDH plug gauges
- CJ1XDL Plastic packaging for TDH/TLH/TXH plug gauges

TDH gauge sizes

| | | B1 mm | B2 mm | B3 mm | C mm |
|--------------------|--|-------|-------|-------|------|
| A mm | | | | | |
| $0,050 \div 0,100$ | | 10,3 | 31,8 | 33,6 | 0,8 |
| $0,100 \div 0,150$ | | 10,5 | 32 | 34 | 1,0 |
| $0,150 \div 0,200$ | | 10,7 | 32,2 | 34,2 | 1,2 |
| $0,200 \div 0,250$ | | 10,9 | 32,4 | 34,4 | 1,4 |
| $0,250 \div 0,300$ | | 11,1 | 32,6 | 34,6 | 1,6 |

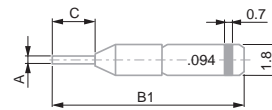

TESA CARY Plug Gauges, Diameters 0,050 to 0,300 mm – Type TLH

This type is identical to the TDH one, but with a 30 mm long handle.

- EN ISO 1938
- Steel
- Accuracy: STANDARD (blue handle) $\pm 0,4 \mu\text{m}$. ETALON (yellow handle) $\pm 0,15 \mu\text{m}$
- Light alloy, coloured handle with engraved nominal diameter
- Inspection report available on request



| No | | | |
|---------|------------------------|--------------------|---------------------|
| | μm | mm | Step, μm |
| CJ1L1S2 | $\pm 0,4 \mu\text{m}$ | $0,050 \div 0,080$ | 2 |
| CJ1L2S2 | $\pm 0,4 \mu\text{m}$ | $0,081 \div 0,309$ | 2 |
| CJ1L1S0 | $\pm 0,4 \mu\text{m}$ | $0,050 \div 0,080$ | 1 |
| CJ1L2S0 | $\pm 0,4 \mu\text{m}$ | $0,081 \div 0,309$ | 1 |
| CJ1L1E2 | $\pm 0,15 \mu\text{m}$ | $0,050 \div 0,080$ | 2 |
| CJ1L2E2 | $\pm 0,15 \mu\text{m}$ | $0,081 \div 0,309$ | 2 |
| CJ1L1E0 | $\pm 0,15 \mu\text{m}$ | $0,050 \div 0,080$ | 1 |
| CJ1L2E0 | $\pm 0,15 \mu\text{m}$ | $0,081 \div 0,309$ | 1 |

OPTIONAL ACCESSORIES:

- CJ1EL25N Wooden case for 25 TLH plug gauges
- CJ1XDL Plastic packaging for TDH/TLH/TXH plug gauges

TLH gauge sizes

| | | B1 mm | B2 mm | B3 mm | C mm |
|--------------------|--|-------|-------|-------|------|
| A mm | | | | | |
| $0,050 \div 0,100$ | | 10,3 | 31,8 | 33,6 | 0,8 |
| $0,100 \div 0,150$ | | 10,5 | 32 | 34 | 1,0 |
| $0,150 \div 0,200$ | | 10,7 | 32,2 | 34,2 | 1,2 |
| $0,200 \div 0,250$ | | 10,9 | 32,4 | 34,4 | 1,4 |
| $0,250 \div 0,300$ | | 11,1 | 32,6 | 34,6 | 1,6 |



TESA CARY Plug Gauges, Diameters 0,100 to 0,300 mm – Type TLH-5 – Type TLH-10

Length of 5 or 10 mm.



| | μm | mm | Step, μm |
|----------|-----------------------|---------------|---------------------|
| CJ1L5S2 | $\pm 0,5 \mu\text{m}$ | 0,101 ÷ 0,309 | 2 |
| CJ1L10S2 | $\pm 0,8 \mu\text{m}$ | 0,101 ÷ 0,309 | 2 |
| CJ1L5S0 | $\pm 0,5 \mu\text{m}$ | 0,101 ÷ 0,309 | 1 |
| CJ1L10S0 | $\pm 0,8 \mu\text{m}$ | 0,101 ÷ 0,309 | 1 |
| CJ1L5E2 | $\pm 0,2 \mu\text{m}$ | 0,101 ÷ 0,309 | 2 |
| CJ1L10E2 | $\pm 0,3 \mu\text{m}$ | 0,101 ÷ 0,309 | 2 |
| CJ1L5E0 | $\pm 0,2 \mu\text{m}$ | 0,101 ÷ 0,309 | 1 |
| CJ1L10E0 | $\pm 0,3 \mu\text{m}$ | 0,101 ÷ 0,309 | 1 |

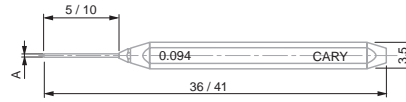

EN ISO 1938



Steel



Accuracy:
STANDARD
(blue handle)
TLH-5 $\pm 0,5 \mu\text{m}$,
TLH-10 $\pm 0,8 \mu\text{m}$;
ETALON (yellow
handle)
TLH-5 $\pm 0,2 \mu\text{m}$,
TLH-10 $\pm 0,3 \mu\text{m}$



Light alloy,
coloured
handle
with engraved
nominal
diameter



Inspection
report available
on request

TESA CARY Plug Gauges, Diameters 0,050 to 0,300 mm – Type TTLH

Double-ended plug gauges consisting of two TDH-type plug gauges.



| | μm | mm | Step, μm |
|----------|------------------------|---------------|---------------------|
| CJ1LL1S0 | $\pm 0,4 \mu\text{m}$ | 0,050 ÷ 0,080 | 1 |
| CJ1LL2S0 | $\pm 0,4 \mu\text{m}$ | 0,081 ÷ 0,309 | 1 |
| CJ1LL1E0 | $\pm 0,15 \mu\text{m}$ | 0,050 ÷ 0,080 | 1 |
| CJ1LL2E0 | $\pm 0,15 \mu\text{m}$ | 0,081 ÷ 0,309 | 1 |

TTLH gauge sizes

| A mm | B1 mm | B2 mm | B3 mm | C mm | | |
|---------------|-------|-------|-------|------|--|--|
| 0,050 ÷ 0,100 | 10,3 | 31,8 | 33,6 | 0,8 | | |
| 0,100 ÷ 0,150 | 10,5 | 32 | 34 | 1,0 | | |
| 0,150 ÷ 0,200 | 10,7 | 32,2 | 34,2 | 1,2 | | |
| 0,200 ÷ 0,250 | 10,9 | 32,4 | 34,4 | 1,4 | | |
| 0,250 ÷ 0,300 | 11,1 | 32,6 | 34,6 | 1,6 | | |

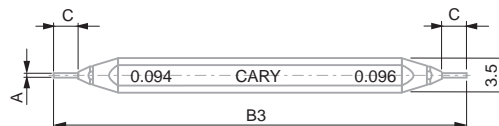

EN ISO 1938



Steel



Accuracy:
STANDARD
(blue handle)
 $\pm 0,4 \mu\text{m}$.
ETALON (yellow
handle) $\pm 0,15 \mu\text{m}$



Light alloy,
coloured
handle
with engraved
nominal
diameter



Inspection
report available
on request



EN ISO 1938

Steel

Accuracy: STANDARD (blue handle) $\pm 0,4 \mu\text{m}$ for diameters $0,3 \div 3 \text{ mm}$ or $\pm 0,5 \mu\text{m}$ for diameters $3 \div 10 \text{ mm}$. ETALON (yellow handle) $\pm 0,25 \mu\text{m}$ for diameters $0,3 \div 3 \text{ mm}$ or $\pm 0,3 \mu\text{m}$ for diameters $3 \div 10 \text{ mm}$.

Light alloy, coloured handle with engraved nominal diameter

Inspection report available on request

TESA CARY Steel Plug Gauges, Diameters 0,3 to 10 mm – Type TXH

Single-ended steel plug gauges (1 item).



| No | μm | mm | Step, μm |
|----------|---------------|---------------------|---------------------|
| CJ1X1S10 | $\pm 0,4$ | $0,300 \div 1,509$ | 10 |
| CJ1X2S10 | $\pm 0,4$ | $1,510 \div 3,509$ | 10 |
| CJ1X3S10 | $\pm 0,5$ | $3,510 \div 10,000$ | 10 |
| CJ1X1S2 | $\pm 0,4$ | $0,300 \div 1,509$ | 2 |
| CJ1X2S2 | $\pm 0,4$ | $1,510 \div 3,509$ | 2 |
| CJ1X1S0 | $\pm 0,4$ | $0,300 \div 1,509$ | 1 |
| CJ1X2S0 | $\pm 0,4$ | $1,510 \div 3,509$ | 1 |
| CJ1X3S0 | $\pm 0,5$ | $3,510 \div 10,000$ | 1 |
| CJ1X1E10 | $\pm 0,25$ | $0,300 \div 1,509$ | 10 |
| CJ1X2E10 | $\pm 0,25$ | $1,510 \div 3,509$ | 10 |
| CJ1X3E10 | $\pm 0,3$ | $3,510 \div 10,000$ | 10 |
| CJ1X1E2 | $\pm 0,25$ | $0,300 \div 1,509$ | 2 |
| CJ1X2E2 | $\pm 0,25$ | $1,510 \div 3,509$ | 2 |
| CJ1X1E0 | $\pm 0,25$ | $0,300 \div 1,509$ | 1 |
| CJ1X2E0 | $\pm 0,25$ | $1,510 \div 3,509$ | 1 |
| CJ1X3E0 | $\pm 0,3$ | $3,510 \div 10,000$ | 1 |

OPTIONAL ACCESSORIES:

| | |
|---------|---|
| CJ1PTXK | Box for 50 plug gauges from $\varnothing 0,300 \div 1,509 \text{ mm}$ |
| CJ1MTXK | Box for 50 plug gauges from $\varnothing 0,510 \div 3,509 \text{ mm}$ |
| CJ1GTXK | Box for 50 plug gauges from $\varnothing 3,510 \div 10,00 \text{ mm}$ |

Gauge sizes TXH

| \varnothing | A mm | B1 mm | B2 mm | C mm | D mm |
|-------------------|------|-------|-------|------|------|
| $0,30 \div 0,50$ | | 38 | 41 | 3 | 3,5 |
| $0,50 \div 1,00$ | | 39 | 43 | 4 | 3,5 |
| $1,00 \div 1,50$ | | 40 | 45 | 5 | 3,5 |
| $1,50 \div 2,00$ | | 46 | 52 | 6 | 5 |
| $2,00 \div 2,50$ | | 47 | 54 | 7 | 5 |
| $2,50 \div 3,00$ | | 48 | 56 | 8 | 5 |
| $3,00 \div 3,50$ | | 49 | 58 | 9 | 5 |
| $3,50 \div 4,00$ | | 60 | 70 | 10 | 8 |
| $4,00 \div 5,00$ | | 61 | 72 | 11 | 8 |
| $5,00 \div 10,00$ | | 62 | 74 | 12 | 8 |

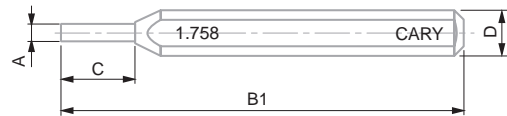

EN ISO 1938

Steel

Accuracy: STANDARD (blue handle) $\pm 0,4 \mu\text{m}$ for diameters $0,3 \div 3 \text{ mm}$ or $\pm 0,5 \mu\text{m}$ for diameters $3 \div 10 \text{ mm}$. ETALON (yellow handle) $\pm 0,25 \mu\text{m}$ for diameters $0,3 \div 3 \text{ mm}$ or $\pm 0,3 \mu\text{m}$ for diameters $3 \div 10 \text{ mm}$.

Light alloy, coloured handle with engraved nominal diameter

Inspection report available on request

TESA CARY Steel Plug Gauges, Diameters 0,3 to 10 mm – Type TTXH

Steel plug gauges, type GO/NO GO (2 items).

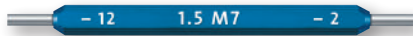

| No | μm | mm | Step, μm |
|----------|---------------|---------------------|---------------------|
| CJ1XX1S0 | $\pm 0,4$ | $0,300 \div 1,509$ | 1 |
| CJ1XX2S0 | $\pm 0,4$ | $1,510 \div 3,509$ | 1 |
| CJ1XX3S0 | $\pm 0,5$ | $3,510 \div 6,509$ | 1 |
| CJ1XX4S0 | $\pm 0,5$ | $6,510 \div 10,000$ | 1 |
| CJ1XX1E0 | $\pm 0,25$ | $0,300 \div 1,509$ | 1 |
| CJ1XX2E0 | $\pm 0,25$ | $1,510 \div 3,509$ | 1 |
| CJ1XX3E0 | $\pm 0,3$ | $3,510 \div 6,509$ | 1 |
| CJ1XX4E0 | $\pm 0,3$ | $6,510 \div 10,000$ | 1 |

OPTIONAL ACCESSORIES:

| | |
|---------|---|
| CJ1PTXK | Box for 50 plug gauges from $\varnothing 0,300 \div 1,509 \text{ mm}$ |
| CJ1MTXK | Box for 50 plug gauges from $\varnothing 0,510 \div 3,509 \text{ mm}$ |
| CJ1GTXK | Box for 50 plug gauges from $\varnothing 3,510 \div 10,00 \text{ mm}$ |

TTXH gauge sizes

| \varnothing | A mm | B1 mm | B2 mm | C mm | D mm |
|-------------------|------|-------|-------|------|------|
| $0,30 \div 0,50$ | | 38 | 41 | 3 | 3,5 |
| $0,50 \div 1,00$ | | 39 | 43 | 4 | 3,5 |
| $1,00 \div 1,50$ | | 40 | 45 | 5 | 3,5 |
| $1,50 \div 2,00$ | | 46 | 52 | 6 | 5 |
| $2,00 \div 2,50$ | | 47 | 54 | 7 | 5 |
| $2,50 \div 3,00$ | | 48 | 56 | 8 | 5 |
| $3,00 \div 3,50$ | | 49 | 58 | 9 | 5 |
| $3,50 \div 4,00$ | | 60 | 70 | 10 | 8 |
| $4,00 \div 5,00$ | | 61 | 72 | 11 | 8 |
| $5,00 \div 10,00$ | | 62 | 74 | 12 | 8 |

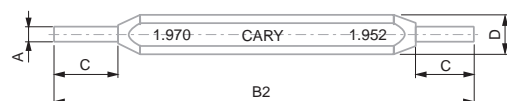

TESA CARY Tungsten Carbide Plug Gauges, Diameters 0,3 to 6 mm – Type TCH

Single-ended tungsten carbide plug gauges (1 item).

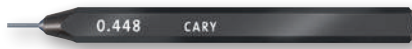

| No | | | | |
|----------|--------|---------------|----------|--|
| | µm | mm | Step, µm | |
| CJ1C1S10 | ± 0,4 | 0,300 ÷ 1,509 | 10 | |
| CJ1C2S10 | ± 0,4 | 1,510 ÷ 3,509 | 10 | |
| CJ1C3S10 | ± 0,5 | 3,510 ÷ 6,000 | 10 | |
| CJ1C1S0 | ± 0,4 | 0,300 ÷ 1,509 | 1 | |
| CJ1C2S0 | ± 0,4 | 1,510 ÷ 3,509 | 1 | |
| CJ1C3S0 | ± 0,5 | 3,510 ÷ 6,000 | 1 | |
| CJ1C1E10 | ± 0,25 | 0,300 ÷ 1,509 | 10 | |
| CJ1C2E10 | ± 0,25 | 1,510 ÷ 3,509 | 10 | |
| CJ1C3E10 | ± 0,3 | 3,510 ÷ 6,000 | 10 | |
| CJ1C1E0 | ± 0,25 | 0,300 ÷ 1,509 | 1 | |
| CJ1C2E0 | ± 0,25 | 1,510 ÷ 3,509 | 1 | |
| CJ1C3E0 | ± 0,3 | 3,510 ÷ 6,000 | 1 | |

OPTIONAL ACCESSORIES:

| | |
|---------|--|
| CJ1PTXK | Box for 50 plug gauges from Ø 0,300 ÷ 1,509 mm |
| CJ1MTXK | Box for 50 plug gauges from Ø 0,510 ÷ 3,509 mm |
| CJ1GTXK | Box for 50 plug gauges from Ø 3,510 ÷ 10,00 mm |

TCH Plug gauge sizes

| | | A mm | B1 mm | B2 mm | C mm | D mm |
|--------------|--|------|-------|-------|------|------|
| 0,30 ÷ 0,50 | | 38 | 41 | 3 | 3,5 | |
| 0,50 ÷ 1,00 | | 39 | 43 | 4 | 3,5 | |
| 1,00 ÷ 1,50 | | 40 | 45 | 5 | 3,5 | |
| 1,50 ÷ 2,00 | | 46 | 52 | 6 | 5 | |
| 2,00 ÷ 2,50 | | 47 | 54 | 7 | 5 | |
| 2,50 ÷ 3,00 | | 48 | 56 | 8 | 5 | |
| 3,00 ÷ 3,50 | | 49 | 58 | 9 | 5 | |
| 3,50 ÷ 4,00 | | 60 | 70 | 10 | 8 | |
| 4,00 ÷ 5,00 | | 61 | 72 | 11 | 8 | |
| 5,00 ÷ 10,00 | | 62 | 74 | 12 | 8 | |

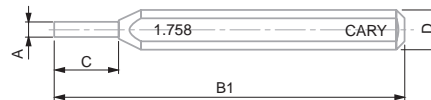

TESA CARY Tungsten Carbide Plug Gauges, Diameters 0,3 to 6 mm – Type TTCH

Tungsten carbide plug gauges, type GO/NO GO (2 items).



| No | | | | |
|----------|--------|---------------|----------|--|
| | µm | mm | Step, µm | |
| CJ1CC1S0 | ± 0,4 | 0,300 ÷ 1,509 | 1 | |
| CJ1CC2S0 | ± 0,4 | 1,510 ÷ 3,509 | 1 | |
| CJ1CC3S0 | ± 0,5 | 3,510 ÷ 6,000 | 1 | |
| CJ1CC1E0 | ± 0,25 | 0,300 ÷ 1,509 | 1 | |
| CJ1CC2E0 | ± 0,25 | 1,510 ÷ 3,509 | 1 | |
| CJ1CC3E0 | ± 0,3 | 3,510 ÷ 6,000 | 1 | |

CONSISTING OF:

| | |
|---------|--|
| CJ1PTXK | Box for 50 plug gauges from Ø 0,300 ÷ 1,509 mm |
| CJ1MTXK | Box for 50 plug gauges from Ø 0,510 ÷ 3,509 mm |
| CJ1GTXK | Box for 50 plug gauges from Ø 3,510 ÷ 10,00 mm |

Plug gauge sizes TTCH

| | | A mm | B1 mm | B2 mm | C mm | D mm |
|--------------|--|------|-------|-------|------|------|
| 0,30 ÷ 0,50 | | 38 | 41 | 3 | 3,5 | |
| 0,50 ÷ 1,00 | | 39 | 43 | 4 | 3,5 | |
| 1,00 ÷ 1,50 | | 40 | 45 | 5 | 3,5 | |
| 1,50 ÷ 2,00 | | 46 | 52 | 6 | 5 | |
| 2,00 ÷ 2,50 | | 47 | 54 | 7 | 5 | |
| 2,50 ÷ 3,00 | | 48 | 56 | 8 | 5 | |
| 3,00 ÷ 3,50 | | 49 | 58 | 9 | 5 | |
| 3,50 ÷ 4,00 | | 60 | 70 | 10 | 8 | |
| 4,00 ÷ 5,00 | | 61 | 72 | 11 | 8 | |
| 5,00 ÷ 10,00 | | 62 | 74 | 12 | 8 | |

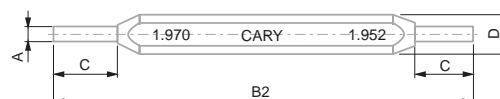

EN ISO 1938

Tungsten carbide

Accuracy:
STANDARD (black handle) ± 0,4 µm for diameters 0,3 ÷ 3 mm or ± 0,5 µm for diameters 3 ÷ 6 mm.
ETALON (red handle) ± 0,25 µm for diameters 0,3 ÷ 3 mm or ± 0,3 µm for diameters 3 ÷ 6 mm.



Light alloy, coloured handle with engraved nominal value



Inspection report available on request



EN ISO 1938

Tungsten carbide

Accuracy:
STANDARD (black handle) ± 0,4 µm for diameters 0,3 ÷ 3 mm or ± 0,5 µm for diameters 3 ÷ 6 mm.
ETALON (red handle) ± 0,25 µm for diameters 0,3 ÷ 3 mm or ± 0,3 µm for diameters 3 ÷ 6 mm.



Light alloy, coloured handle with engraved nominal value



Inspection report available on request

TESA CARY Measuring Pins in Steel, Ø 0,10 to 10 mm, Type PNH with Handle, for Thread Measurement



EN ISO 1938

Hardened steel, ground and lapped

Accuracy: STANDARD (blue handle) $\pm 0,8 \mu\text{m}$ for diameters 0,1 ÷ 10 mm. ETALON (yellow handle) $\pm 0,3 \mu\text{m}$ for diameters 0,1 ÷ 6 mm or $\pm 0,5 \mu\text{m}$ for diameters 6 ÷ 10 mm

Aluminium, coloured handle with engraved nominal diameter

Inspection report available on request

| No | μm | mm | Step, μm |
|--------|---------------|--------------|---------------------|
| CJ1N1S | $\pm 0,8$ | 0,10 ÷ 0,15 | 10 |
| CJ1N2S | $\pm 0,8$ | 0,16 ÷ 0,50 | 10 |
| CJ1N3S | $\pm 0,8$ | 0,51 ÷ 4,00 | 10 |
| CJ1N4S | $\pm 0,8$ | 4,01 ÷ 10,00 | 10 |
| CJ1N1E | $\pm 0,3$ | 0,10 ÷ 0,15 | 10 |
| CJ1N2E | $\pm 0,3$ | 0,16 ÷ 0,50 | 10 |
| CJ1N3E | $\pm 0,3$ | 0,51 ÷ 4,00 | 10 |
| CJ1N4E | $\pm 0,5$ | 4,01 ÷ 10,00 | 10 |

OPTIONAL ACCESSORIES:

| | |
|---------|--|
| CJ1N50 | Suited clear box for 50 PNH thread wires |
| CJ1N3 | Carrying tube for 3 PNH thread wires |
| CJ1NGC | Box engraving for each diameter |
| CJ1NLSM | Thread wire alone, without handle |

Plug gauge sizes PNH

| \varnothing | | A mm | B mm | C mm | D mm | E mm |
|---------------|--|------|------|------|------|------|
| 0,10 ÷ 0,15 | | 20 | 9,5 | 1,8 | 0,9 | |
| 0,16 ÷ 0,30 | | 32 | 9,5 | 1,8 | 0,9 | |
| 0,31 ÷ 1,10 | | 32 | 14 | 3,5 | 1,5 | |
| 1,11 ÷ 10,00 | | 32 | 14 | 5 | 2 | |

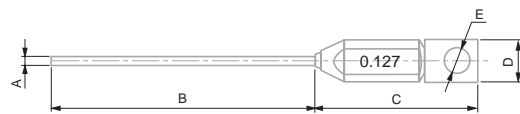

Accessories for Plug Gauges and Setting Rings



| No | = |
|----------|---|
| CJ1ED25N | Wooden case for 25 TDH plug gauges |
| CJ1EL25N | Wooden case for 25 TLH plug gauges |
| CJ1XDL | Plastic packaging for TDH/TLH/TXH plug gauges |
| CJ1PTXK | Box for 50 plug gauges from $\varnothing 0,300 \div 1.509$ mm |
| CJ1MTXK | Box for 50 plug gauges from $\varnothing 0,510 \div 3.509$ mm |
| CJ1GTXK | Box for 50 plug gauges from $\varnothing 3,510 \div 10,00$ mm |
| CJ1N50 | Suited clear box for 50 PNH thread wires |
| CJ1N3 | Carrying tube for 3 PNH thread wires |
| CJ1NGC | Box engraving for each diameter |
| CJ1NLSM | Thread wire alone, without handle |



TESA CARY Carbide Ring Gauges, Diameters 0,060 to 5 mm, Type BCH

Type BCH 1 Carbide ring gauge Type BIMHm

2 BCH carbide ring gauges mounted in pairs on plates for use as GO/NO GO type gauges.

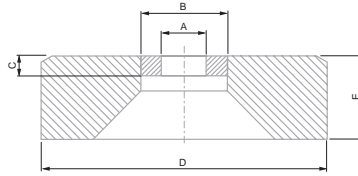

| No | = | ∅ | A |
|---------|-------|---------------|----------|
| | | mm | Step, µm |
| CJ1B1C | BCH | 0,060 ÷ 0,150 | 1 |
| CJ1B2C | BCH | 0,151 ÷ 1,500 | 1 |
| CJ1B3C | BCH | 1,501 ÷ 2,500 | 1 |
| CJ1B4C | BCH | 2,501 ÷ 4,000 | 1 |
| CJ1B5C | BCH | 4,001 ÷ 4,999 | 1 |
| CJ1B1IM | BIMHm | 0,060 ÷ 0,150 | 1 |
| CJ1B2IM | BIMHm | 0,151 ÷ 1,500 | 1 |
| CJ1B3IM | BIMHm | 1,501 ÷ 2,500 | 1 |
| CJ1B4IM | BIMHm | 2,501 ÷ 4,000 | 1 |
| CJ1B5IM | BIMHm | 4,001 ÷ 4,999 | 1 |

Ring gauges sizes BCH

| ∅ | Ring gauges | | | Outer rings | |
|--------------|-------------|------|------|-------------|------|
| | A mm | B mm | C mm | D mm | E mm |
| 0,060 ÷ 0,50 | 1,8 | 0,5 | 8 | 2,5 | |
| 0,50 ÷ 0,75 | 1,8 | 0,5 | 8 | 2,5 | |
| 0,75 ÷ 1,25 | 2,4 | 0,75 | 8 | 2,5 | |
| 1,25 ÷ 1,50 | 3 | 0,9 | 8 | 2,5 | |
| 1,50 ÷ 2,50 | 5 | 1,5 | 12 | 4 | |
| 2,50 ÷ 4,00 | 8 | 2,4 | 16 | 5,5 | |
| 4,00 ÷ 5,00 | 10 | 3 | 20 | 7 | |



EN ISO 1938
Factory standard



∅ 0,015 ÷ 3 mm:
± 0,6 µm
∅ 3 ÷ 4,999 mm:
± 0,75 µm



Tungsten carbide



Inserted into a blue coloured, light alloy ring for easier handling. Also with engraved nominal diameter of the ring



Inspection report from 2 mm available on request

TESA CARY Steel Ring Gauges, Diameters 0,151 to 5 mm, Type BAH

Designed for inspecting cylindrical components such as pivots or axles.

Used to determine external diameters.

Type BAH 1 steel ring gauge.

Type BIMHa 2 BAH steel ring gauges mounted in pairs on plates for use as GO/NO GO type gauges

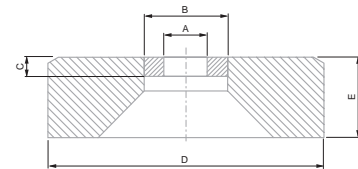

| No | = | ∅ | A |
|---------|-------|---------------|----------|
| | | mm | Step, µm |
| CJ1B2A | BAH | 0,151 ÷ 1,500 | 1 |
| CJ1B3A | BAH | 1,501 ÷ 2,500 | 1 |
| CJ1B4A | BAH | 2,501 ÷ 4,000 | 1 |
| CJ1B5A | BAH | 4,001 ÷ 4,999 | 1 |
| CJ1B2IA | BIMHa | 0,151 ÷ 1,500 | 1 |
| CJ1B3IA | BIMHa | 1,501 ÷ 2,500 | 1 |
| CJ1B4IA | BIMHa | 2,501 ÷ 4,000 | 1 |
| CJ1B5IA | BIMHa | 4,001 ÷ 4,999 | 1 |

Ring gauge sizes BAH

| ∅ | Ring gauges | | | Outer rings | |
|--------------|-------------|------|------|-------------|------|
| | A mm | B mm | C mm | D mm | E mm |
| 0,060 ÷ 0,50 | 1,4 | 0,35 | 8 | 2,5 | |
| 0,50 ÷ 0,75 | 1,8 | 0,5 | 8 | 2,5 | |
| 0,75 ÷ 1,25 | 2,4 | 0,75 | 8 | 2,5 | |
| 1,25 ÷ 1,50 | 3 | 0,9 | 8 | 2,5 | |
| 1,50 ÷ 2,50 | 5 | 1,5 | 12 | 4 | |
| 2,50 ÷ 4,00 | 8 | 2,4 | 16 | 5,5 | |
| 4,00 ÷ 5,00 | 10 | 3 | 20 | 7 | |



EN ISO 1938
Factory standard



∅ 0,15 ÷ 3 mm:
± 0,6 µm
∅ 3 ÷ 4,999 mm:
± 0,75 µm



Steel



Inserted into a light alloy, blue coloured ring for easier handling. Also with engraved nominal diameter.



Inspection report from 2 mm available on request



EN ISO 1938
Factory standard

5 ÷ 10 mm dia.:
± 1,25 µm
10 ÷ 18 mm dia.:
± 1,5 µm
18 ÷ 29,99 mm dia.:
± 2 µm

Steel

Inserted into a light alloy, grey coloured ring for easier handling. Also with engraved nominal diameter

Inspection report available on request

TESA CARY Steel Ring Gauges, Diameters 5 to 30 mm, Type BOMa

Type BOMa, 1 steel ring gauge.

Type BBOMa, 2 BOMa steel ring gauges mounted in pairs on plates for use as GO/NO GO type gauges.

| No | = | ∅ | A |
|---------|-------|---------------|----------|
| | | mm | Step, µm |
| CJ1BOA1 | BOMa | 5,00 ÷ 9,99 | 1 |
| CJ1BOA2 | BOMa | 10,00 ÷ 11,99 | 1 |
| CJ1BOA3 | BOMa | 12,00 ÷ 13,99 | 1 |
| CJ1BOA4 | BOMa | 14,00 ÷ 15,99 | 1 |
| CJ1BOA5 | BOMa | 16,00 ÷ 17,99 | 1 |
| CJ1BOA6 | BOMa | 18,00 ÷ 19,99 | 1 |
| CJ1BOA7 | BOMa | 20,00 ÷ 22,99 | 1 |
| CJ1BOA8 | BOMa | 23,00 ÷ 25,99 | 1 |
| CJ1BOA9 | BOMa | 26,00 ÷ 29,99 | 1 |
| CJ1BBA1 | BBOMa | 5,00 ÷ 9,99 | 1 |
| CJ1BBA2 | BBOMa | 10,00 ÷ 11,99 | 1 |
| CJ1BBA3 | BBOMa | 12,00 ÷ 13,99 | 1 |
| CJ1BBA4 | BBOMa | 14,00 ÷ 15,99 | 1 |
| CJ1BBA5 | BBOMa | 16,00 ÷ 17,99 | 1 |
| CJ1BBA6 | BBOMa | 18,00 ÷ 19,99 | 1 |
| CJ1BBA7 | BBOMa | 20,00 ÷ 22,99 | 1 |
| CJ1BBA8 | BBOMa | 23,00 ÷ 25,99 | 1 |
| CJ1BBA9 | BBOMa | 26,00 ÷ 29,99 | 1 |



Ring gauges sizes BOMa

| ∅ | Ring gauges | Outer rings | | | | |
|---------|-------------|-------------|------|------|------|--|
| A mm | B mm | C mm | D mm | E mm | F mm | |
| 5 ÷ 10 | 18 | 2 | 30 | 4 | 10,5 | |
| 10 ÷ 14 | 24 | 2,5 | 38 | 5 | 15 | |
| 14 ÷ 18 | 30 | 3 | 46 | 6 | 19 | |
| 18 ÷ 24 | 38 | 3,5 | 56 | 8 | 25 | |
| 24 ÷ 30 | 46 | 4 | 68 | 8 | 31 | |

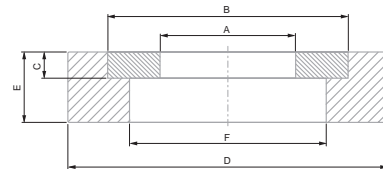

EN ISO 1938
Factory standard

∅ 5 ÷ 10 mm:
± 1,25 µm
∅ 10 ÷ 18 mm:
± 1,5 µm
∅ 18 ÷ 29,99 mm:
± 2 µm
Better quality upon request (Q5)
∅ 5 ÷ 10 mm: ± 1 µm
∅ 10 ÷ 18 mm: ± 1,2 µm
∅ 18 ÷ 29,99 mm: ± 1,5 µm

Tungsten carbide

Inserted into a light alloy, grey coloured ring for easier handling. Also with engraved nominal diameter.

Inspection report available on request

TESA CARY Tungsten Carbide Ring Gauges, Diameters 5 to 30 mm, Type BOMm

Type BOMm, 1 Tungsten carbide ring gauge.

Type BBOMm, 2 BOMm carbide ring gauges mounted in pairs on plates for use as GO/NO GO plug gauges

| No | = | ∅ | A |
|---------|-------|---------------|----------|
| | | mm | Step, µm |
| CJ1BOM1 | BOMm | 5,00 ÷ 9,99 | 1 |
| CJ1BOM2 | BOMm | 10,00 ÷ 11,99 | 1 |
| CJ1BOM3 | BOMm | 12,00 ÷ 13,99 | 1 |
| CJ1BOM4 | BOMm | 14,00 ÷ 15,99 | 1 |
| CJ1BOM5 | BOMm | 16,00 ÷ 17,99 | 1 |
| CJ1BOM6 | BOMm | 18,00 ÷ 19,99 | 1 |
| CJ1BOM7 | BOMm | 20,00 ÷ 22,99 | 1 |
| CJ1BOM8 | BOMm | 23,00 ÷ 25,99 | 1 |
| CJ1BOM9 | BOMm | 26,00 ÷ 29,99 | 1 |
| CJ1BBM1 | BBOMm | 5,00 ÷ 9,99 | 1 |
| CJ1BBM2 | BBOMm | 10,00 ÷ 11,99 | 1 |
| CJ1BBM3 | BBOMm | 12,00 ÷ 13,99 | 1 |
| CJ1BBM4 | BBOMm | 14,00 ÷ 15,99 | 1 |
| CJ1BBM5 | BBOMm | 16,00 ÷ 17,99 | 1 |
| CJ1BBM6 | BBOMm | 18,00 ÷ 19,99 | 1 |
| CJ1BBM7 | BBOMm | 20,00 ÷ 22,99 | 1 |
| CJ1BBM8 | BBOMm | 23,00 ÷ 25,99 | 1 |
| CJ1BBM9 | BBOMm | 26,00 ÷ 29,99 | 1 |



Ring gauges sizes BOMm

| ∅ | Ring gauges | Outer rings | | | | |
|---------|-------------|-------------|------|------|------|--|
| A mm | B mm | C mm | D mm | E mm | F mm | |
| 5 ÷ 10 | 18 | 2 | 30 | 4 | 10,5 | |
| 10 ÷ 14 | 24 | 2,5 | 38 | 5 | 15 | |
| 14 ÷ 18 | 30 | 3 | 46 | 6 | 19 | |
| 18 ÷ 24 | 38 | 3,5 | 56 | 8 | 25 | |
| 24 ÷ 30 | 46 | 4 | 68 | 8 | 31 | |

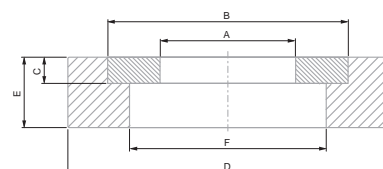

Accessories for Plug Gauges

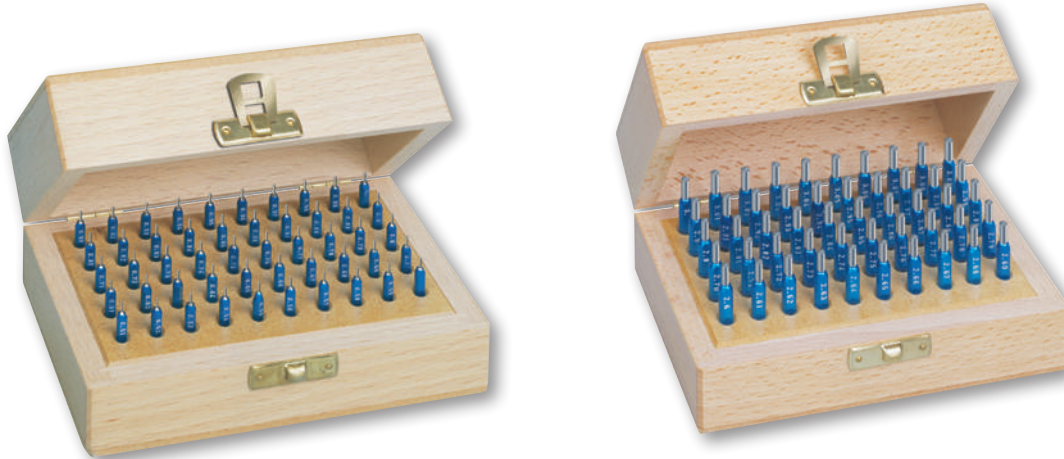

| No | = |
|--------------|--|
| CJ1ED25N | Wooden case for 25 TDH plug gauges |
| CJ1EL25N | Wooden case for 25 TLH plug gauges |
| CJ1XDL | Plastic case for TDH/TLH/TXH plug gauges |
| CJ1PTXK | Box for 50 plugs 0,300 ÷ 1.509 mm |
| CJ1MTXK | Box for 50 plugs 0,510 ÷ 3.509 mm |
| CJ1GTXK | Box for 50 plugs 3,510 ÷ 10,000 mm |
| CJ1N50 | Suited clear box for 50 PNH thread wires |
| CJ1N3 | Carrying tube for 3 PNH thread wires |
| CJ1NGC | Box engraving for each diameter |
| CJ1NLSM | Thread wire alone, without handle |
| CJ1CEB3 | Suited case for 3 rings from Ø 0,06 ÷ 1,50 mm |
| CJ1CB40 | Suited case for 12 rings from Ø 1,50 ÷ 2,50 mm |
| CJ1CB24 | Suited case for 24 rings from Ø 2,50 ÷ 4,00 mm |
| CJ1CB18 | Suited case for 12 rings from Ø 4,00 ÷ 5,00 mm |
| CJ128021010A | Aluminium resting plate for 2 rings from Ø 0,06 ÷ 1,50 mm |
| CJ128021011A | Aluminium resting plate for 2 rings from Ø 1,51 ÷ 2,50 mm |
| CJ128021012A | Aluminium resting plate for 2 rings from Ø 2,51 ÷ 4,00 mm |
| CJ128021013A | Aluminium resting plate for 2 rings from Ø 4,01 ÷ 5,0 mm |
| CJ1BAA | Bearing ring (one for each ring gauge from Ø 0,06 ÷ 5,00 mm) |
| CJ1CEB4 | Suited case for 4 rings from Ø 0,06 ÷ 1,50 mm |
| CJ1EB12 | Suited case for 12 rings from Ø 0,06 ÷ 1,50 mm |
| CJ1BBA | Resting ring (one item for each ring gauge from Ø 5,00 ÷ 30,00 mm) |



Calibration Equipment



CONFIDENCE IS NOT ENOUGH...

The control of inspection and measuring equipment is an element of quality management that is now more important than ever before. The introduction of the ISO 9000 family of international standards has also led to major changes in this field. Amongst other things, ISO 9001 specifies that : "all inspection and measuring equipment that can affect product quality must be identified, calibrated and adjusted at prescribed intervals, or prior to use, against certified equipment having a known valid traceable relationship to internationally or nationally recognised standards".

This standard also states that the supplier shall: "ensure that the inspection and measuring equipment is capable of the necessary accuracy and precision".

A Vast Choice

TESA can offer you the most varied methods of measurement specifically suited for the inspection and calibration of standards, handtools and plug gauges. Some of these are described in the various sections of this catalogue, in particular:

- Gauge blocks
- Setting rings
- Cylindrical setting standards with outside diameters
- Optical flats
- Parallel optical flats
- Electronic levels for both straightness and flatness measurement
- Instruments for both squareness and perpendicularity measurement
- Calibration equipment for length measuring devices fitted with inductive probes.



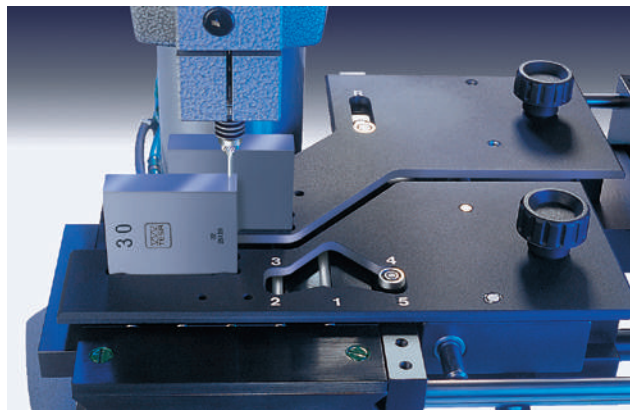
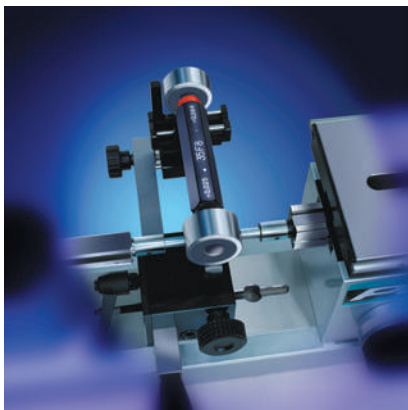



This section is devoted to measuring systems that serve to calibrate other inspection equipment, but they can also be used for high-accuracy measurement of precision parts.

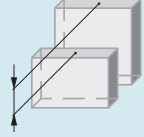
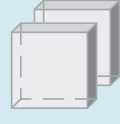

PRESENTATION OF TESA MEASURING GAGE BLOCKS

TESA offers two models, the operation of which is based on two different measurement procedures.

- TESA UPD directly measures gauge blocks within a measuring span of 25 mm/1 in.
- TESA UPC is used for comparative measurement of gauge blocks having a same nominal length.

| TESA Gauge Block Comparators | | UPD | UPC |
|---|--|---|------------------------------------|
|  | Measuring procedures <ul style="list-style-type: none"> - Comparison of different nominal lengths up to 25 mm - Number of reference gauge blocks required for the calibration of a set of 122 pieces: 9 blocks - Number of blocks required for the calibration of the device: 9 blocks + 6 pairs |  | ● ● ● |
| | Comparative measurement <ul style="list-style-type: none"> - Comparison of gauge blocks having the same nominal length - Number of reference gauge blocks required for the calibration of a set of 122 pieces: 122 blocks - Number of gauge blocks required for the calibration of the device: 6 pairs |  | ● ● ● ● ● ● |
|  | Measuring errors Read also the explanations provided in this same chapter with regard to the measuring errors of each instrument | | |
| | Repeatability limit | 0,015 µm 0,025 µm | ● ● ● |
| | Measuring uncertainty | $U = \pm (0,05 + 0,5 \cdot L) \mu\text{m L in m}$ $U = \pm (0,10 + 1,0 \cdot L) \mu\text{m}$ | ● ● ● |
|  | Range of application Nominal lengths | 0,5 to 100 mm/0.02 to 4.0 in 0,5 to 500 mm/0.02 to 20 in | ● ● ▲ ▲ |
|  | Measuring range 25 mm/1 in | | ● |
|  | Sensors for capturing length dimensions <ul style="list-style-type: none"> - 2 axial probes in sum measurement - Digital measuring system, opto-electronic with incremental divisions - Analogue measuring system, electronic and inductive - Activation of the measuring force <ul style="list-style-type: none"> • electro-motorised • by spring force - Retraction of the measuring bolt <ul style="list-style-type: none"> • electro-motorised • by vacuum | | ● ● ● ● ● ● ● ● ● ● |
| | Template system <ul style="list-style-type: none"> - Single template system - Dual template system | | ● ● ● ○ |
| | Positioning of gauge blocks with a nominal length of up to 10 mm Suction loader with an electric vacuum pump | | ○ ○ |
|  | TESA UPT temperature measuring device Measurement of the electrical resistance using 4 thermal sensors (4 wire type) | | ● ○ |
|  | TESA software for processing the measured values <ul style="list-style-type: none"> - TESA UP, WINDOWS 98, 2000, NT, XP, 7 (32 bits) | | ● ● |
| ▲ Available on request ○ Recommended option | | | |



GAUGE BLOCK COMPARATORS

In the hierarchical chain of dimensional measurements that can be traced back to the standard metre length unit, gauge blocks hold a key position. This makes them the most important material references used in metrology.

The application of the length unit, based on specific wavelengths of light, to gauge blocks is achieved in the first instance by fundamental interferential measurement. Using gauge blocks measured by interferometry, defined lengths are thus transferred to other gauge blocks in measurements further down the hierarchical chain.

TESA UPD – for Direct and Comparative Measurements

- Direct measurement of gauge blocks with a variation in nominal length of up to 25 mm or 1 in.
 - Enables the number of reference gauge blocks required to be reduced by nearly 80 %.
- Comparative measurement of gauge blocks having a same nominal length.
 - Enables lower measurement uncertainties to be achieved due to weaker influences of the systematic errors.
- Equipped with HEIDENHAIN high-precision incremental probes.
- Templates with a new concept for positioning the gauge blocks.
 - Single or dual template system to provide optimum ease of handling of the gauge blocks
- Integrated device for most accurate temperature acquisition.
- On-line transfer of both measured length and temperature values.
- Computer-aided data processing with all the corrections necessary included.

Dual template system for the maintenance of your reference gauge blocks (TESA patented)

- The simultaneous use of two templates allows you to "rest up" your gauge blocks until you need them.
- The application of this new concept turns into significant savings in both time and money.
- During measurement cycles carried out on a routine basis, the distance travelled over the measuring table is reduced by nearly 70 %.
 - This contributes to significant reductions of the risks of damaging and wearing the measurement faces.
- The double protection of your reference gauge blocks leads to significant cost savings through the reduction if the need for:
 - recalibration
 - restoration of the measuring faces
 - replacement of worn or damaged gauge blocks
 - increased downtime (whilst extending the life of your reference gauge blocks)

Single Template System

- Using this system your reference gauge blocks are moved together with those to be calibrated during the measurement cycles.



EN ISO 3650
(ASME B89.1.9-2002 on request)

For gauge blocks with nominal lengths from 0,5 mm to 100 mm / 0.02 in to 4 in

Measuring configuration
Two probes with mechanical contact with the measuring face to be probed are connected in sum measurement (function +A+B).

Measuring points
On the reference gauge block: at the centre of the measuring face (point R). On the gauge block to be measured: at the centre (point 1) as well as the four corners of the measuring face, each lying 2 mm away from the adjacent faces (points 2 to 5).

The central length l_c is determined by probing both points R and 1. For establishing lengths at any point, the measurements shall be carried out at points R plus 1 to 5.

The variation in length v is obtained from measurements taken at points 1 to 5.



Packed suitable for shipping

Identification number

Calibration certificate from the supplier for the comparator or the Swiss Calibration Service for the temperature device.

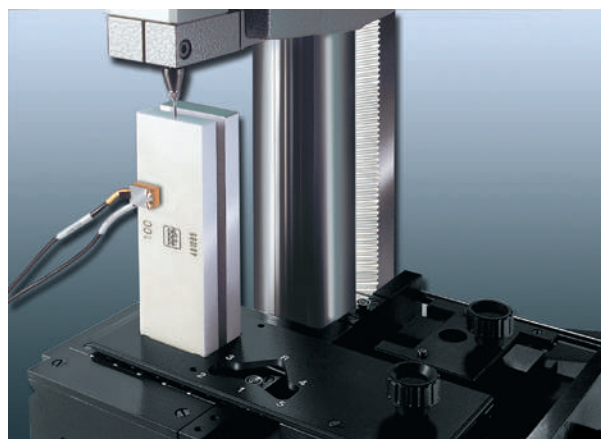

2 different delivery programs

| No | = | | |
|-----------------------|--|---|---|
| 05930005 | TESA UPD gauge block comparator with temperature device* | | ● |
| 05930004 | TESA UPD gauge block comparator without temperature device | ● | |
| <i>CONSISTENT OF:</i> | | | |
| 05930008 | TESA UPD mechanical part | ● | ● |
| 05960016 | HEIDENHAIN computing counter ND 287 featuring 2 probe inputs | ● | ● |
| 05960013 | Control panel | ● | ● |
| 05960014 | Connecting cable for control panel to ND 287 computing counter | ● | ● |
| 04768001 | Foot switch | ● | ● |
| 01660011 | Suction loader | | ● |
| 03260433 | Electrical vacuum pump with external control, 230 VAC, 50 Hz | | ● |
| 05960028 | Connecting cable for electronic vacuum pump to control panel | | ● |
| 05930011 | TESA UPT temperature device, complete | | ● |

Other delivery program available on request
 * Special execution for 110 VAC, 60 Hz also available on request (ref. S32070030 instead of 03260433)

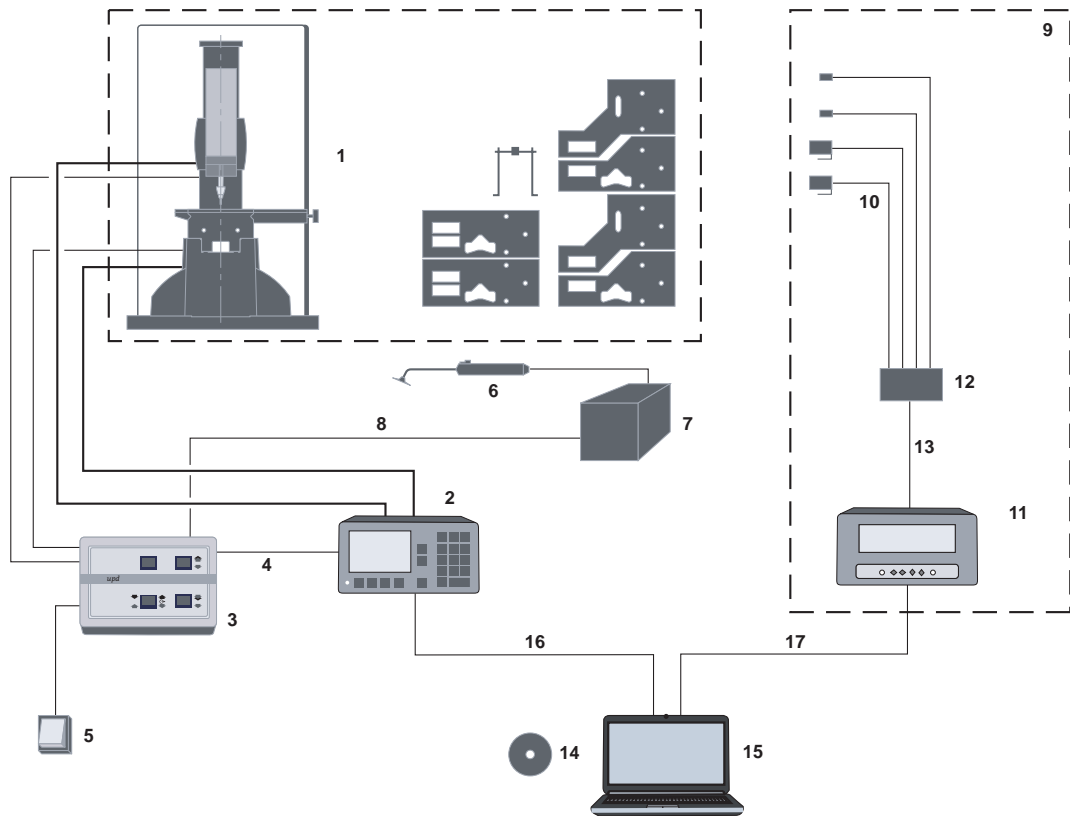

Errors of Measurement

Provided all metrological conditions are met, the reliability of the comparator used for direct measurement of steel gauge blocks is expressed as follows:

- Repeatability limit (with no influence of external temperature): 0,015 µm
- Uncertainty of measurement: $U = \pm (0,05 + 0,5 \cdot L) \mu\text{m}$ (L in m)
- Condition requires the use of reference standards whose measurement uncertainty is equal to:
 $U \leq \pm 0,015 \mu\text{m}$ for the comparator
 $U \leq \pm (0,02 + 0,2 \cdot L) \mu\text{m}$ (L in m) for the gauge blocks



TESA UPC – for Comparative Measurement

TESA UPC Gauge Block Comparator for Comparative Measurement

- Measures gauge blocks of same nominal length by comparison.
- Comes with the new template system for positioning the gauge blocks.
- Single or dual template system for optimum ease of gauge handling.
- Features TESA high-precision inductive probes.
- Allows ultra-precise temperature measurement, integrated.
- Transfers on-line all measured length and temperature values.
- Executes computer-aided data processing with all required correction values included.
- Performs calibrations that meet the requirements of both ISO standards and EA guidelines (EAL – European cooperation for Accreditation of Laboratories).
- Includes an execution for greater accuracy along with a calibration certificate (optional).



TESA UPC is specially designed for the calibration – or dimensional inspection – of gauge blocks with nominal lengths ranging from 0,5 to 100 mm. The configuration, which consists of two probes aligned opposite one another, associated with both the concept and quality of the measuring system provides full guarantee for an extra low uncertainty of measurement. Although TESA UPC is mainly intended for manufacturers and end-users of gauge blocks, this comparator is also widely used in nationally accredited laboratories.



If specified, TESA can also provide the temperature device available as an option. This device has 4 PT100 platinum resistances, each capturing the temperature of the two gauge blocks along with that of both the measuring table and the support. Computer-aided data processing lets you carry out any calibration most reliably and rationally – for sure.



EN ISO 3650



For gauge blocks ranging from 0,5 mm to 100 mm or 0.02 in to 4 in (0,5 to 500 mm on request)



Comparative measurement procedure with transference of the length of a reference gauge block to the gauge block being measured. Measuring configuration 2 probes connected in sum measurement (function +A+B) with mechanical contact with the measuring face.

Measuring points
On the reference gauge block: at the centre of the measuring face (point R). On the gauge block to be measured: at the centre (point 1) as well as the 4 corners of the measuring face, each lying 2 mm away from the adjacent faces (points 2 to 5).

Central length l_c is defined by probing both points R and 1.

Establishing lengths at any point requires measurements to be taken at points R plus 1 to 5.

Variation in length v is the result of measurements taken at points 1 to 5.



≈ 23 kg (comparator complete, but without computer).
≈ 4 kg (temperature device)



Packed suitable for shipping



All instruments with the option for greater accuracy are delivered with serial numbers



In-house calibration certificate for the version with greater accuracy or declaration of conformity for the standard version. Temperature device with SCS certificate.



| No | | | | | |
|--|---|---|---|---|---|
| TESA UPC GAUGE BLOCK COMPARATOR EQUIPPED WITH SINGLE TEMPLATE SYSTEM | | | | | |
| 05930000 | Standard execution without computer application | | | | ● |
| 05930003 | Execution for greater accuracy, with computer application | | | ● | ● |
| TESA UPC GAUGE BLOCK COMPARATOR EQUIPPED WITH SINGLE AND DUAL TEMPLATE SYSTEM | | | | | |
| 05930013 | Execution for greater accuracy without computer application | | ● | | |
| 05930015 | Execution for greater accuracy, with computer application | ● | | | |
| EACH VERSION CONSISTS OF: | | | | | |
| 01610401 | TESA UPC mechanical part equipped with the single template system | | | ● | ● |
| 05960030 | TESA UPC mechanical part equipped with both single and dual template system | ● | ● | | |
| 03260401 | Pneumatic retraction of the measuring bolt, manually operated | | | | ● |
| 03260432 | Electric vacuum pump with foot switch | | ● | | |
| 03260433 | Electric vacuum pump with external control | ● | | ● | |
| 01660011 | Pneumatic suction loader | ● | ● | ● | |
| 04430012 | TESATRONIC electronic unit TT90 | ● | ● | ● | ● |
| 05960039 | Set of TESA UPC accessories, including the components 04761049, 04760087 and 04761070 | | | | |
| 04761049 | Opto-RS cable, bidirectional | ● | | ● | |
| 04760087 | Opto-RS interface | ● | | ● | |
| 04761070 | Connecting cable TESATRONIC TT90 to vacuum pump | ● | | ● | |
| 04768000 | Hand switch | ● | | ● | |
| 01690021 | Option for greater accuracy with calibration certificate | ● | ● | ● | |

Error of Measurement

Provided all the metrological conditions are met, the reliability of the two standard executions No. 05930000 and 05930002 is expressed as follows:

Provided all the metrological conditions are met, the reliability of both executions No. 05930001 and 05930003 along with the option for greater accuracy (No. 01690021) is expressed as follows:

Repeatability limit (with no effect due to external temperature): 0,025 µm

Repeatability limit (with no effect due to external temperature): 0,015 µm

Measurement uncertainty*
 $U = \pm (0,10 + 1,0 \cdot L) \mu\text{m}$ (L in m)

Measurement uncertainty*
 $U = \pm (0,05 + 0,5 \cdot L) \mu\text{m}$ (L in m)

Condition involves the use of reference standards (see page L-14 and L-15) whose uncertainty is as follows:
 $U \leq \pm 0,030 \mu\text{m}$
 when calibrating the comparator
 $U \leq \pm (0,05 + 0,5 \cdot L) \mu\text{m}$ (L in m)
 when calibrating the gauge blocks

Condition involves the use of reference standards (see page L-14 and L-15) whose uncertainty is as follows:
 $U \leq \pm 0,015 \mu\text{m}$
 when calibrating the comparator
 $U \leq \pm (0,02 + 0,2 \cdot L) \mu\text{m}$ (L in m)
 when calibrating the gauge blocks

* Applicable to steel gauge blocks

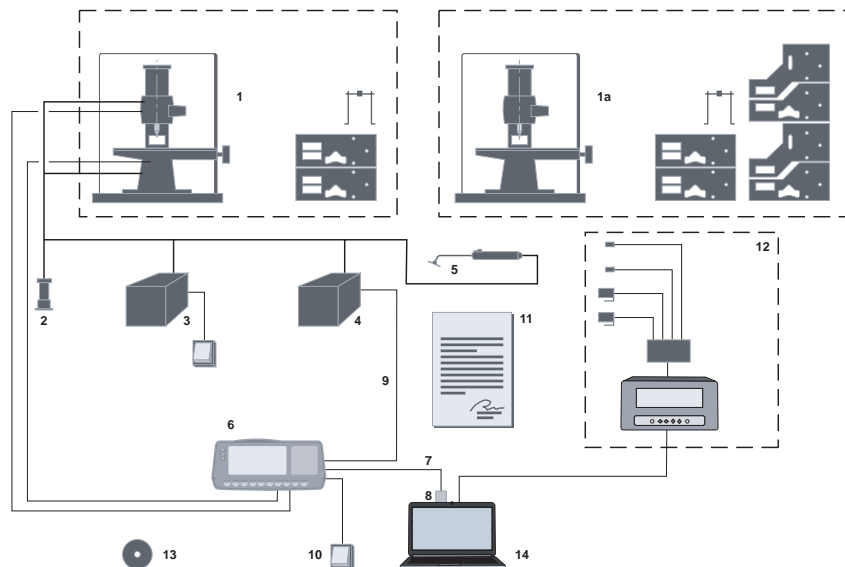

TESA UP – Software Programme for Value Processing

TESA UP programme for processing measured values suitable for both TESA gauge block comparators UPD and UPC as well as for comparators from other manufacturers.

- Choice of 10 languages.
- On-line processing of length and temperature values as transferred.
- Measurement cycles and result outputs according to EN ISO 3650.
- Flexible architecture for optimum adaptation to specific user's needs.
- Possible entry of limit values and accuracy grades peculiar to users.
- Surveillance of value dispersion or value drift throughout length and temperature measurements.
- Automatic execution of all relevant corrections. The programme makes allowances for actual sizes of the reference standards, flattening due to different materials used (steel, tungsten carbide, ceramic), compensation of temperature variations with reference to 20°C according to the varying coefficients of linear expansion – as typical examples.
- Assignment of gauge blocks to their relevant grade.
- Possible storage of gauge block set related data.
- Inch or metric value processing.
- Calibration certificate in several formats.

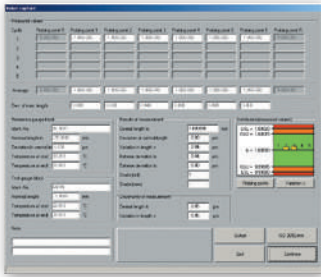

| | | |
|-----------------|--|---------------------------------------|
| | | |
| 05960025 | TESA UP software programme for gauge block calibration | 1 CD-ROM plus 1 USB key of protection |

Gauge Blocks for the Calibration of Comparators

To calibrate both TESA gauge block comparators UPD and UPC, we recommend the use of the gauge block set described hereafter. The 9-piece set is also required for calibrating TESA UPD.

Set composition including 11 gauge blocks.

Each pair is in full compliance with:

- EAL-G21 – Calibration of gauge block comparators – European cooperation for Accreditation of Laboratories
- DKD-R 4-1 – Guidelines of the German Calibration Service (DKD) for the calibration of gauge block comparators.

| | | | |
|------------------|---|--|---------|
| | | | µm |
| S59110152 | Set of 11 gauge blocks with PTB (Physikalisch Technische Bundesanstalt) certificate | | ± 0,015 |
| S59110489 | Set of 11 gauge blocks with DAkkS certificate | | ± 0,030 |

Full tungsten carbide set also available on request

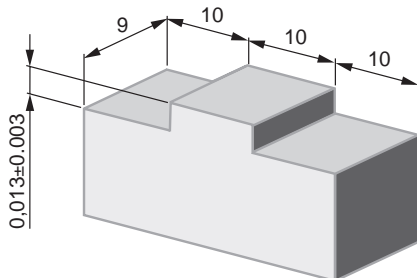

| | | Nominal length | |
|----------|-------|----------------|--|
| Pairs N° | A mm | B mm | |
| 1 | 0,5 | 0,5 | |
| 2 | 1,0 | 1,005 | |
| 3 | 1,0 | 1,01 | |
| 4 | 4,5 | 4,5 | |
| 5 | 100,0 | 100,0 | |
| 6 | 6,0 | 6,0 * | |

* Special bridge-shaped gauge blocks (see drawing) used for establishing the measuring deviations of lower probe B.

- EN ISO 3650
- Minimum profile requirements for the computer needed to run the TESA UP software programme Personal Computer
 - Configuration without heat source to avoid disturbing the ambient temperature at the measurement spot
 - Operating system: Windows 7 or earlier versions (32 bits)
 - Processor: 650 MHz
 - 1 Hard disc (6 GB)
 - RAM capacity: 64 MB
 - CD-ROM drive (24x)
 - RS232 serial port
 - 1 for length values
 - 1 for temperature values
 - 3 USB ports
- mm/In units

- EN ISO 3650
- Special high-alloy steel, wear resistant and stable. Exception: 6 mm special carbide gauge blocks.
- Wooden case
- PTB or DKD calibration certificate
- Serial number identification
- The given expanded uncertainty $k = 3$ refers to the difference of central length of both gauge blocks A and B forming the pairs 1 to 5 as well as to the deviations f_0 and f_u from the central length of gauge blocks forming both pairs 2 and 3. No need to calibrate those of pair No. 6.
- Class K



EN ISO 3650



Special high-alloy steel wear resistant and stable



Wooden case



For calibration certificates, see opposite



Serial number identification

Expanded uncertainty $k = 2$ is valid for that given



Grade K



Additional Gauge Block Set for Calibration of the TESA UPD System

In order to achieve the lowest uncertainty of measurement, we recommend the use of grade K gauge blocks which have been measured directly by interferometry and are supplied with a calibration certificate, irrespective of any other requirement such as the ambient conditions.

| No | = |  |
|-----------|---|---|
| S59300103 | Set 9 gauge blocks with METAS certificate (Swiss) | $\pm 0,02 + 0,2 \cdot L \mu\text{m}$ (L in m) |
| S59300107 | Set 9 gauge blocks with PTB certificate (Germany) | $\pm 0,02 + 0,2 \cdot L \mu\text{m}$ (L in m) |
| S59300104 | Set 9 gauge blocks with SCS certificate | $\pm 0,05 + 0,5 \cdot L \mu\text{m}$ (L in m) |

| | |
|---|---|
|  | Set composition (mm) 1 / 5 / 10 / 15 / 20 / 25 / 50 / 75 / 100 |
|  | Steel |
|  | Accuracy grade K |

Other set composition or carbide gauge blocks also available on request.

TESA UPT

Fully calibrated for the measuring ranges from 19°C up to 24°C with a numerical interval to 0,001°C.

Supplied with a calibration certificate issued by the Swiss Calibration Service (SCS). Uncertainty of measurement achieved during calibration $U = \pm 0,03^\circ\text{C}$.

| No | = |
|----------------|--|
| 05930011 | Temperature measurement device |
| CONSISTING OF: | |
| 05960018 | Set of 4 temperature sensors PT 100 |
| 05960038 | Measuring unit for temperature, FLUKE 1529 |
| 05960012 | Interface Box 4 x PT 100 |
| 05960011 | Connecting cable for adapter No. 05960012 to measuring unit No. 05960038 |
| 05960026 | Connecting cable from UPC to computer (9-pin/m and 9-pin/f connector) |



ETALON POLO HORIZONTAL MEASURING BENCH

A giant for small sizes – Specially designed for the control of measuring and test equipment in compliance with ISO 9000.

- Application range from 0 up to 100 mm for external dimensions of 2,5 up to 110 mm for internal dimensions – 50 mm measuring span.
- Resolution to 0,001 or 0,0001 mm – Metric/Inch conversion.
- Maximum permissible error of 0,5 μm .
- Measuring force from 0 to 4 N.
- Comes with a calibration certificate issued by the supplier.



Calibration of Standards:

- Cylindrical test pins
- Setting standards with cylindrical, plane-parallel measuring faces
- Threaded reference gauges (calibrated using the 3-wire method)
- Setting masters
- Setting rings

Workpiece Inspection:

External dimensions

- Stepped shafts
- Cutting tools
- Cylindrical pins
- Ball tips
- Grooves
- Short centring shoulders
- Threads (measured according to the 3-wires method)

Internal dimensions

- Through bores
- Blind bores
- Centring grooves
- Slots
- Sliding guides

Calibration of Plus Gauges:

- Limit plug gauges
- Plug gauges "GO"
- Plug gauges "NO GO"
- Plain plug gauges
- Ring gauges "GO"
- Ring gauges "NO GO"
- Threaded plug gauges

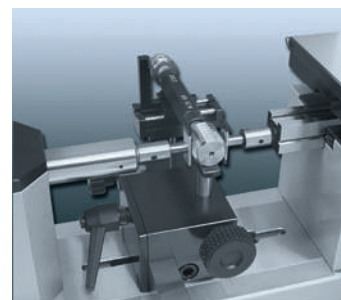
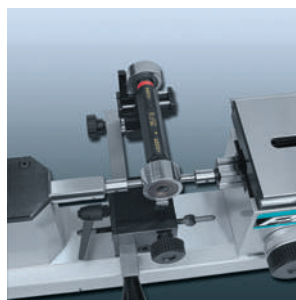
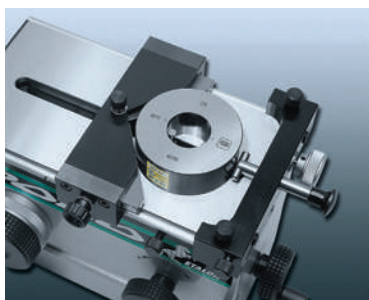



Max. perm. error within the measuring span: 0,5 µm with standard accessories



0,1 µm



Opto-electronic measuring system with incremental glass scale, type LIF - HEIDENHAIN



Tilting range of the floating table ± 0,5°



-10°C to 40°C



10°C to 40°C



EN 50081-1
EN 50082-2
EN 61000-4-2
EN 61000-4-4



Setting 0 to 4N



50 mm measuring span



19 kg net (main part alone, without table). Floating table: 2,8 kg net



8,0 • 10-6/°C



• 0 to 100 mm for external dimensions
• 10 to 110 mm with standard accessories
• 2,5 to 110 mm with optional accessories

ETALON POLO with Floating Resting Table

Calibration of measuring instruments

- Dial Gauges
- Lever Dial Test Indicators
- Electronic transducers



05939001 ETALON POLO measuring bench with floating table and electronic computing counter

CONSISTING OF:

- 05919002** Main part
- 05969024** 1 pair of inserts for external dimensions
- 05969015** Floating measuring table
- 05969029** HEIDENHAIN computing counter ND 287

DELIVERED WITH THE FOLLOWING ACCESSORIES:

- 05969020** 1 Pair of standard inserts for internal dimensions from 10 mm
- 05969030** Protective cover



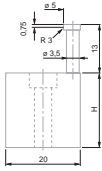

05969020

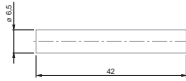

05969024

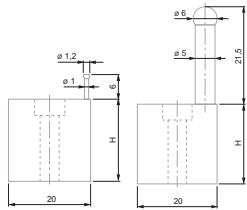

05969021

05969022

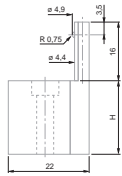

05969023

Pair of Standard Measuring Inserts for External and Internal Dimensions from 10 mm

| No | = | Description |
|----------|---|--|
| 05969020 | | 1 Pair of standard inserts for internal dimensions from 10 mm To be used with floating table N° 05960015, H = 20 mm |
| 05969024 | | 1 pair of inserts for external dimensions 6,5mm Ø carbide inserts with a flat face |



Packed suitable for shipping

Measuring Inserts for Internal Measurement used with the Floating Resting Table

Height H = 20 mm. M4 locking screw.

| No | = | Description |
|----------|---|--|
| 05969021 | | Internal measuring inserts from 2,5 mm Barrel-shaped inserts with a 1,2 mm dia. carbide ball tip. |
| 05969022 | | Internal measuring inserts from 13 mm Fitted with a 6 mm dia. carbide ball tip. |
| 05969023 | | Internal measuring inserts from 5 mm Fitted with a 1,5 mm dia. carbide ball tip. |



Bench Stand with Swivelling Plate

For raising the measuring bench from horizontal to vertical position. Accommodates a clamp lever. Length (upright): 295 mm, mass ≈ 20 kg.

| No | = | Description |
|----------|---|-----------------------------------|
| 05969000 | | Bench stand with swivelling plate |



Base for the Computing Counter

Base for raising up the HEIDENHAIN ND 287 counting unit, height 380 mm, weight 5,2 kg.

| No | = | Description |
|----------|---|-----------------------------|
| 05969001 | | Stand for computing counter |

Floating Resting Table

Used for external measurement on oblong parts up to 60 mm in diameter; centres, L=160 mm; movable positioning fixture for parts having varying lengths, 3 freedom degrees.



| No | = | Description |
|----------|---|----------------------------|
| 05969032 | | Resting table without vise |
| 05969033 | | Vise for plug gauges |
| 05969034 | | Floating table |

Stands for Checking External Dimensions



| No | = | Description |
|----------|---|-----------------------------|
| 05969007 | | Ø 3 mm stand for external Ø |
| 05969008 | | Ø 6 mm stand for external Ø |





Stand with Ø 10 mm Fixing Bores

For H-shaped table (05969003) and for control system for lever-type indicator (05969004)



05969002 Stand with Ø 10 mm bore for 05969003 and 05969004

Centering Device

Allows the user to search for the transverse culmination point against the measuring direction. Used with either the fixed or floating table No. 05969014 or 05969015. Prismatic stop adjustable transversely, max. diameter 110 mm. Counter pressure piece finished with cylindrical stop pins.



05969012 Centering device for culmination point

Fixing Shank

For clamping the instruments that need to be calibrated such as dial gauges or precision indicators etc.



059690010



05969010 For fixing shafts with a Ø 8 mm
05969011 For fixing shafts with a Ø 3/8 in

Holder for a Dial Test Indicator (Lever-type)

Provided with 2 dovetail clamps, TESATAST-type or in compliance with BS 2795:1981



05969004 Holding device for test indicator

Spindle for Calibrating Dial Gauges, Dial Test Indicators and such like

Setting range = 50 mm, Spindle rotation = 0,5 mm



05969009 Spindle for calibrating dial gauges, dial test indicators and such like





Surface Roughness Testing

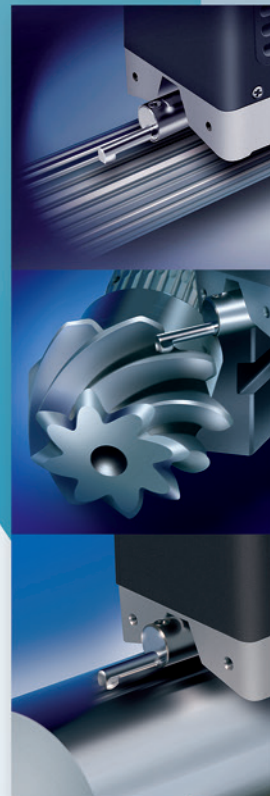

THE ROUGHNESS PARAMETERS MOST COMMONLY USED ARE: RA, RZ AND RMAX

TESA RUGOSOFT and MEASUREMENT STUDIO Software

These software tools allow the storage of surface roughness measurements along with roughness parameters and roughness profile. A measuring programme created in the software can be transferred to the instrument together with measuring parameters. The results are available at all times, complete with statistical analysis and can be exported for reports, for example.

Mean roughness Ra (ISO 4287, DIN 4768)

The mean roughness Ra matches the arithmetical mean of the absolute values related to the profile deviation y within the reference length l.

Max. profile valley depth Rmax (DIN 4768)

The max. profile valley depth Rmax is for the most significant single roughness depth Zi within the total length lm.

According to ISO 4288 and DIN 4287 - Part 1, this parameter is also specified as Ry max.

Mean roughness depth Rz DIN (DIN 4768)

The mean roughness depth Rz is the arithmetical mean of single roughness depths of successive sampling lengths le. According to ISO 4287 and DIN 4762, the parameter Rz DIN is also specified as Ry5.

Since Rz changes its name in both DIN 4768 and ISO 4287, this parameter is also specified as Rz DIN or Rz ISO. If the parameter Rz is measured according to DIN, it is generally admitted that the extreme value specified by ISO is matched providing that Rz ISO does not exceed Rz DIN.

Use of Roughness Comparison Specimens

These specimens are used for testing any surface finish quality and have long proven their value in practice.

They are used for touch and/or sight comparisons against the surface of work pieces that are produced using the same manufacturing process. The condition is that materials have to be comparable.

When comparing the workpiece surface against the specimen, roughness is not quantitatively expressed. The assessment of the extent to which the surface finish of both is alike can only be subjective.

Sight comparison requires optimum light source angle. For small surfaces, the use of a magnifying glass with up to 8x magnification is recommended.

Touch comparison is made using the finger tip or a small copper piece such as a coin, for instance.



RUGOSURF 20

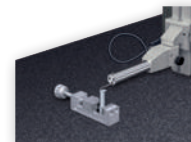

RUGOSURF 90G in profile measuring mode with PROFILE SET 2 mm

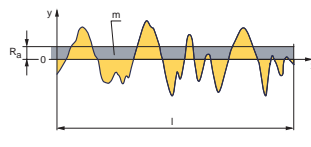
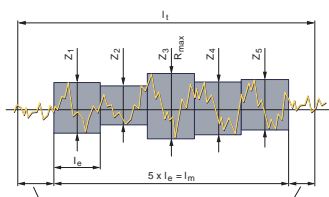

RUGOSURF 20 with dot matrix printer

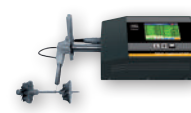

RUGOSURF 90G



RUGOSURF 20, RUGOSURF 10G, RUGOSURF 90G ROUGHNESS GAUGES

TESA offers a range of 3 portable RUGOSURF roughness gauges adapted for different levels of precision from the production floor to the test laboratory.

These devices are particularly appreciated by operators for their ease of use, robustness and reliability.

The range includes data management software to process measured values for an optimal overview of roughness profiles, statistical data and customizable measurement reports.



RUGOSURF 20



RUGOSURF 10G



RUGOSURF 90G



TESA RUGOSURF 20

Portable roughness gauge, robust and versatile.
Well suited for production environments or inspection of inward goods.

Measures roughness parameters according to:

- ISO 4287
- JIS B0601
- DIN and ISO 12085 (MOTIF or CNOMO).

Measuring range in the Z-axis of 400 μm (6300 μin).
15 roughness parameters.

Each parameter can be activated individually or not.
Possible tolerancing of parameter values.



Scope of supply

Direct display:

- of all measured values, with tolerance levels display,
- of R roughness profile,
- the Bearing Area Curve (BAC),
- the Amplitude Distribution Curve (ADC).



With a measuring stand with suction base

2" Black&White LCD screen, high contrast for optimum visual representation.
Flexible autonomy through mains adapter or battery pack.
Storage of the measured parameters.

Multilingual menu options.

USB cable connection (optional).

Direct printing to a dot matrix printer (optional).

Measurement transfer, database creation and reporting available using TESA RUGOSOFT software tool (optional).

Access to narrow and hard to reach locations possible through 100 mm probe extension (optional).



Measurement of narrow hard to reach crevices thanks to the 100 mm probe extension



With vertical positioning support



- Description:
1. Start / Measure
 2. Probe protection
 3. LCD 2" screen
 4. Enter key
 5. Defilement key
 6. Return key / Measurement parameters
 7. ON/OFF Switch
 8. Batter charger connector
 9. USB Connector for PC
 10. Printer connector



ISO 3274 (Cl.1)



122 x 60 x 62 mm (without probe)



USB



10°C to 40°C



-10°C to +50°C



650 g



Plastic transport case



Declaration of conformity



| | |
|---|--|
|  | 06930013 |
|  | TESA RUGOSURF 20 portable surface roughness tester for use in the workshop Z = ± 200 µm (± 0.0079 in) X = 16 mm (0.63 in) |
|  | Measuring span, µm 400 µm (0.0157 in) on Z axis, 16 mm (0.63 in) on X axis |
|  | Indication span, µm Ra = 0 ÷ 100 µm; Rt = 0,05 ÷ 400 µm |
|  | Accuracy class in accordance with ISO 3274 Class 1 |
|  | Measuring force, N 0,75 mN in accordance with ISO 3274 |
|  | Resolution, µm 0,001 µm |
|  | Display LCD 2" black/white (160 x 100 pixels) |
|  | Roughness parameters Ra, Rq, Rt, Rz, Rc, Rsm, Rmr, Pt, Pmr; Rmax; RPc, PPc; R, Rx, AR |
|  | Graphics Bearing Area Curve (BAC), Amplitude Distribution Curve (ADC), Profile-R |
|  | Cut-off length, mm 0,25 – 0,80 – 2,50 mm (0.010 – 0.030 – 0.100 in) |
|  | Number of cut-off 1 to 5 |
|  | Stylus diamond tip (R = µm; angle °) R = 2 µm, 90° |
|  | Memory capacity max 1000 measurements with parameters; max 20 measurements with profile and graphics |
|  | Dimensions, mm 122 x 60 x 62 mm |
|  | Degree of protection for keyboard (IP XX) IP67 (membrane keyboard) |
|  | Digital data output (USB) USB cable connector to PC |
|  | Weight, g 650 g |
|  | Included in delivery RUGOSURF 20 SB10 standard skid probe Roughness standard Ra = 2,97 µm Positioning pin Ø 8 mm for use vertically Detachable probe protector Integral rechargeable battery Charger and adapter EU/US User manual Plastic carrying and storage case |
|  | Measuring response time 1 to 10 s |
|  | Probing speed, mm/s 1 mm/s (2 mm/s probe retract to measuring position) |
|  | Units mm or inch |
|  | Power supply 100 ÷ 240 VAC; 50 ÷ 60 Hz; 12 V, 400 ÷ 650 mAh |





TECHNOLOGY

OPTIONAL ACCESSORIES:

| | |
|----------|--|
| 04760099 | Cable RUGOSURF 20 to PC |
| 06960033 | Printer for RUGOSURF + cables |
| 06960034 | RUGOSOFT Software + Dongle |
| 06960035 | Granite 400 x 250 mm with vertical support H150 mm, 25 kg, Grade 0 for Rugosurf 20 and 10G |
| 06960081 | Probe SB10 2µm for RUGOSURF 20 and 10G as SB10 but R = 2 µm |
| 06960037 | SB20 probe for RUGOSURF 20 et 10G for grooves of depth < 5 mm |
| 06960038 | SB30 probe for RUGOSURF 20 and 10G for small bores of Ø > 4 mm |
| 06960039 | SB40 Probe for RUGOSURF 20 and 10G V-shape for cylinders of Ø > 1 mm |
| 06960040 | SB50 probe for RUGOSURF 20 and 10G for concave surfaces and for measuring at 90° with RUGOSURF 10G |
| 06960057 | SB110 probe for RUGOSURF 20 and 10G for concave or convex surfaces, R > 5 mm |
| 06960056 | 100 mm extension for probe with skid for RUGOSURF 20, 10G, 90G |
| 06960064 | Roughness standard Ra = 0,1 µm (4 µin) |
| 06960065 | Roughness standard Ra = 0,5 µm (20 µin) |
| 06960066 | Roughness standard Ra = 1,0 µm (40 µin) |

STANDARD ACCESSORIES:

| | |
|----------|---|
| 06960036 | SB10 standard probe for RUGOSURF 20 and 10G R = 5 µm, 90° |
| 06960041 | Roughness standard Ra = 2,97 µm (117 µin) |
| 06960045 | Battery NiMH 7,2 V, 300 mAh, format PP3 for RUGOSURF 20 et 10G |
| 057655 | Vertical and adjustable positioning supports (2 parts) V-form for cylinder Ø > 100 mm for RUGOSURF 20 |
| 057941 | Transport case with internal protection foam for RUGOSURF 20 |



- ISO 3274 (Cl. 1)
- 122 x 53 x 75 mm (without probe)
- USB
- 10°C to 40°C
- 10°C to +50°C
-
- 590 g
- Plastic transport case
- Declaration of conformity

TESA RUGOSURF 10G

Portable, versatile gauge unit with compact design, well suited for use in goods inwards inspection, production or the measurement laboratory.

3 horizontal measuring positions of probe 0°, -90° et +90°.

Measures roughness parameters according to standards:

- ISO 4287
- JIS B0601
- DIN and ISO 12085 (MOTIF or CNOMO).

TFT 2" graphic display for optimum visual representation of any measured parameters and workpiece profiles.

Direct displaying of all measured values and computed profiles.

31 roughness parameters available.

Flexible autonomy through mains adapter or battery pack.

Data storage, printing or transfer to a PC of a maximum of 999 measured results.

Possible tolerancing of all parameter values.

Multilingual menu options.

USB data output enabling a direct connection to a matrix printer unit or a PC equipped with RUGOSOFT 10 software (both are optional).

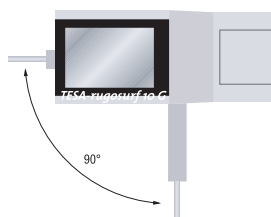

Probe measuring positions at -90°, 0°, +90°

| | |
|--------------|-------------------|
| Ra | 0,088 μm |
| Rq | 0,116 μm |
| Rt | 0,889 μm |
| Rp | 0,264 μm |
| 05:08 | Parameters |

Measuring results

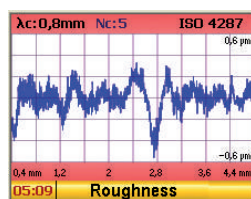

Profile measurement

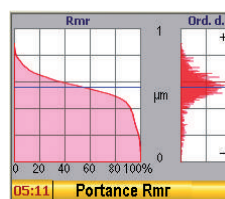

Bearing area curve (BAC) and amplitude distribution curve (ADC)

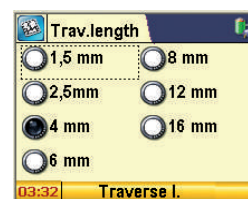

Measuring travel



| | |
|---|---|
|  | 06930011 |
|  | TESA RUGOSURF 10G portable surface roughness tester for use in the workshop Z = ± 200 µm (± 0.0079 in) X = 16 mm (0.63 in) 3 probe measuring positions |
|  | Measuring span, µm 400 µm (6300 µin) on Z axis, 16 mm (0.63 in) on X axis |
|  | Display span, µm Ra = 0 ÷ 100 µm; Rt = 0,05 ÷ 400 µm |
|  | Precision class in accordance with ISO 3274 Class 1 |
|  | Measuring force, N 0,75 mN (in accordance with ISO 3274) |
|  | Resolution, µm 0,001 µm (0.1 µin) |
|  | Display TFT 2" colour graphic screen |
|  | Roughness parameters 31 parameters: Ra, Rq (Rms), Rt, Rz, Rp, Rc, Rv, Rsm, Rdc; Pa, Pq, Pt, Pp, Pc, Pv, Psm, Rdc; RPc, PPc; Rk, Rpk, Pvk, Mr1, Mr2; Pt, R, Rx, AR; R3, R3zm, Rmax; |
|  | Graphics Bearing area curve, profil-R, profil-P |
|  | Cut-off length, mm 0,25 – 0,80 – 2,50 mm (0.01 – 0.03 – 0.10 inch) |
|  | Number of cut-off 1 to 10 for a cut-off of 0,25 and 0,8 mm |
|  | Diamond point of stylus (R = µm; angle °) R = 5 µm, 90° |
|  | Built-in memory Max. 1000 parameters; max. 20 measurements with parameters, profiles and graphics |
|  | Dimensions, mm 122 x 53 x 81 mm |
|  | Degree of protection of keyboard (IP XX) IP67 |
|  | Digital output (USB) USB cable connector to PC |
|  | Weight, g 590 g |
|  | Included in delivery Roughness standard Ra = 2,97 µm Built in rechargeable battery SB10 standard probe Battery charger EU and US Adaptor Positioning clamp for stand Ø 8 mm Vertical positioning stand User instructions |
|  | Probing speed, mm/s 1 mm/s |
|  | Units mm or inch |
|  | Power supply 100 ÷ 240 VAC; 50 ÷ 60 Hz, 12 V, 400 ÷ 650 mAh |



OPTIONAL ACCESSORIES:

| | |
|----------|--|
| 06960062 | Cable RUGOSURF 10G and RUGOSURF 90G to PC (connector v3) |
| 06960033 | Printer for RUGOSURF + cables |
| 06960034 | RUGOSOFT Software + Dongle |
| 06960035 | Granite 400x250 mm with vertical support H 150 mm, 25 kg, Grade 0 for Rugosurf 20 and 10G |
| 06960081 | Probe SB10 2 μ m for RUGOSURF 20 and 10G as SB10 but R = 2 μ m |
| 06960037 | SB20 probe for RUGOSURF 20 et 10G for grooves of depth < 5 mm |
| 06960038 | SB30 probe for RUGOSURF 20 and 10G for small bores of $\varnothing > 4$ mm |
| 06960039 | SB40 Probe for RUGOSURF 20 and 10G V-shape for cylinders of $\varnothing > 1$ mm |
| 06960040 | SB50 probe for RUGOSURF 20 and 10G for concave surfaces and for measuring at 90° with RUGOSURF 10G |
| 06960057 | SB110 probe for RUGOSURF 20 and 10G for concave or convex surfaces, R > 5 mm |
| 06960056 | 100 mm extension for probe with skid for RUGOSURF 20, 10G, 90G |
| 06960064 | Roughness standard Ra = 0,1 μ m (4 μ in) |
| 06960065 | Roughness standard Ra = 0,5 μ m (20 μ in) |
| 06960066 | Roughness standard Ra = 1,0 μ m (40 μ in) |

STANDARD ACCESSORIES:

| | |
|----------|---|
| 06960036 | SB10 standard probe for RUGOSURF 20 and 10G R = 5 μ m, 90° |
| 06960041 | Roughness standard Ra = 2,97 μ m (117 μ in) |
| 06960045 | Battery NiMH 7,2 V, 300 mAh, format PP3 for RUGOSURF 20 et 10G |
| 056631 | Adjustable vertical positioning supports (2 parts) V-form for cylinder $\varnothing > 100$ mm for RUGOSURF 10G |
| 06960047 | Transport case with internal protection foam for RUGOSURF10-10G |





Probe measuring position at 90° and adjustable in height

TESA RUGOSURF 90G

Small-size, versatile roughness gauge with tactile colour screen providing maximum ease of use. Ideally suited for high-precision measurements on the shop floor or in the inspection laboratory.

Special features of RUGOSURF 90G:

- Supplied with SB60/10 probe with removable pad: one single probe can be used to measure roughness or undulation!
- RUGOSURF 90G can measure a components with a height of up to 90mm, thanks to a vertical positioning screw without any additional accessory!
- With the PROFILE SET 2 mm (06960100) RUGOSURF 90G becomes a profile measurement instrument with a width of 2000 µm measuring in the Z axis (optional)!

Tactile TFT 3.5" colour screen.

Direct display of all measured values and computed profiles.

Measuring span

$$Z = 1000 \mu\text{m} (0.039 \text{ in})$$

$$X = \text{up to } 50 \text{ mm}$$



RUGOSURF 90G with tactile colour screen
Measurement with or without skid

Special 2 in 1 probe can measure with contact skid (roughness measurement) or without contact skid (measure of undulation).

Vertical adjusting screw for probe positioning up to a height of 90 mm without the need of an accessory.

Tolerancing of all parameters possible.

USB digital output for transfer of measured values to a PC with TESA MEASUREMENT STUDIO software (optional).

Unique in its category, this instrument can also do profile measurement (Z = 2 mm) if used with PROFILE SET 2 mm (optional).

Measures roughness parameters according to standards:

- ISO 4287
- 12085 (CNOMO)
- ISO 13565
- DIN 4776
- JIS B0601:2001
- ASME B46-2002

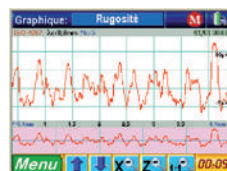
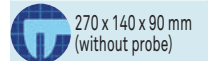

Roughness profile

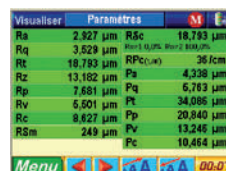

Roughness parameters

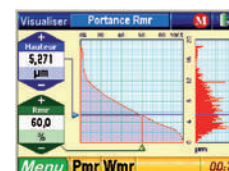

Bearing area curve (BAC) and amplitude distribution curve (ADC)

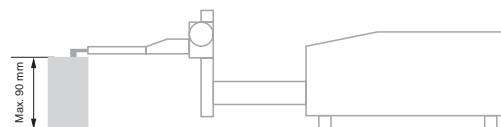

Fine adjustment of vertical position up to 90 mm



| | | |
|---|---|---|
|  | 06930012 | |
|  | | TESA RUGOSURF 90G portable table roughness tester Z = ± 500 µm (± 0.0197 in) X = 50 mm (1.968 in) probe with detachable skid |
|  | Measuring span, µm | Z Axis = 1000 µm (39370 µin); X Axis = 50 mm (1.969 in) |
|  | Indication span, µm | Ra = 0 ÷ 400 µm; Rt = 0 ÷ 1000 µm |
|  | Precision class | In accordance with ISO 3274 Class 1 |
|  | Measuring force, N | 0,75 mN according to ISO 3274 |
|  | Resolution, µm | 0,001 µm (0.01 µin) |
|  | Display | Tactile graphic colour screen TFT 3.5" (320 x 240 pixels) |
|  | Roughness parameters | 48 parameters: Ra, Rq, Rt, Rz, Rp, Rc, Rv, Rsm, Rdc, R _{Pc} , Pa, Pq, Pt, Pp, Pc, Pv, Psm, R _{Pc} , P _{Pc} , Wa, Wq, Wt, Wz, Wp, Wv, Wc, WSm, Wdc, W _{Pc} , Rk, Rpk, Pvk, Mr1, Mr2, Pt, R, Rx, AR, Wte, W, AW, Wx, Rke, R _{pke} , R _{vke} , Rmax, R3z, R3zm |
|  | Graphics | Profil-W, Profil-R, Profil-P, Bearing area curve |
|  | Cut-off length, mm | 0,08 – 0,25 – 0,80 – 2,50 – 8,00 mm |
|  | Number of cut-off | 1 to 19 for cut off up to 2,5 mm; 1 to 5 for cut off of 8,00 mm |
|  | Diamond or stylus tip (R = µm; angle °) | R = 5 µm, 90° |
|  | Memory capacity | Max. 60'000 measurements with parameters |
|  | Dimensions (mm) | 270 x 140 x 90 mm |
|  | Degree of protection of keyboard (IP XX) | IP67 (membrane keyboard) |
|  | Digital output (USB) | USB cable connector to PC |
|  | Weight, kg | 3 kg |
|  | Included in delivery | <ul style="list-style-type: none"> – RUGOSURF 90G – Roughness standard Ra = 2,97 µm – Standard probe SB60/10 with or without skid – Probe holder – Guiding column, vertical setting range 90 mm – Integrated rechargeable battery, 12 V – Charger for battery |
|  | Measuring response time | – |
|  | Probing speed, mm/s | 0,5 mm/s or 1,0 mm/s selection options |
|  | Units | mm or inch |
|  | Power supply | 100 ÷ 240 VAC / 50 ÷ 60 Hz; 18 V, 2,2 Ah |



OPTIONAL ACCESSORIES:

| | |
|----------|--|
| 06960062 | Cable RUGOSURF 10G and RUGOSURF 90G to PC (connector v3) |
| 06960033 | Printer for RUGOSURF + cables |
| 06960048 | MEASUREMENT STUDIO software + dongle for RUGOSURF 90G |
| 06960055 | Granite 630 x 400 mm with vertical support H250mm, 60 kg, Grade 0 for RUGOSURF 90G |
| 06960064 | Roughness standard Ra = 0,1 µm (4 µin) |
| 06960065 | Roughness standard Ra = 0,5 µm (20 µin) |
| 06960066 | Roughness standard Ra = 1,0 µm (40 µin) |
| 06960100 | PROFILE SET 2 mm for profile measurement with RUGOSURF 90G |
| 06960056 | 100 mm extension for probe with skid for RUGOSURF 20, 10G, 90G |
| 06960067 | SB60/10 2µm probe for RUGOSURF 90G as SB60/10 but R = 2 µm |
| 06960050 | SB20P probe for RUGOSURF 90G for grooves of depth < 5 mm |
| 06960051 | SB30P probe for RUGOSURF 90G for small bores with Ø > 4 mm |
| 06960052 | SB40P probe for RUGOSURF 90G V-shape for cylinders with Ø > 1 mm |
| 06960053 | SB50P probe for RUGOSURF 90G for concave surfaces and for measuring at 90° with RUGOSURF 90G |
| 06960054 | SB120P probe for RUGOSURF 90G for grooves of depth < 20 mm |
| 06960058 | SB120S probe without skid for RUGOSURF 90G for grooves of depth < 15 mm |
| 06960061 | SB60-D2-L30 probe, L = 30 mm for RUGOSURF 90G for small bores of Ø > 2 mm |

STANDARD ACCESSORIES:

| | |
|----------|---|
| 06960049 | SB60/10 standard probe for RUGOSURF 90G R = 5 µm, 90° detachable skid |
| 06960041 | Roughness standard Ra = 2,97 µm (117 µin) |
| 056645 | Transport case with internal protective foam for RUGOSURF 90G |





Roughness parameters according to: ISO 4287, ISO 13565-1, ISO 13565-2, ISO 12085, VDA 2007



Z = 2 mm
X = 50 mm



Z = 0,1 μ m
X = 0,4 to 4,0 μ m according to the length being measured



Z = 3,5 + 0,75*H microns, (H in the Z axis, in mm) X = 3,5 + L/10 microns (L in the X axis, in mm)



0,3 mg (0,003 mN) with the SB2000 probe



1 mm/s



Maximum angle of 70° (upward position); maximum angle of 85° (downward position)

TESA PROFILE SET 2 mm

PROFILE SET 2 mm for profile measurement (compatible with RUGOSURF 90G).

When equipped with the SB2000 probe and used with the PROFILE STUDIO software dedicated for profile measurement STUDIO PROFILE, the RUGOSURF 90G roughness gauge converts into a profile-measuring tool.

A simple, ingenious and accurate solution, this optional accessory measures lengths, radii and angles of parts which are sometimes impossible to verify by other means.

The setting up and the evaluation of measurements is simple and fast. Dimensions can be inserted into the measured profile after defining geometric elements (point, line, arc or intersection between two lines, for example). The tolerance values allow verification of the results at a glance. Rotation and symmetry of the profile also allows its orientation.

A previous measurement can be used as model for the repeated measurement of a part of identical geometry. This saves valuable time and facilitates operations as important manual measurements can be replicated automatically.

A standard profile with a measurement report is included in the PROFILE SET 2 mm set.

A detailed measurement report with customizable header can be generated from the PROFILE STUDIO software.

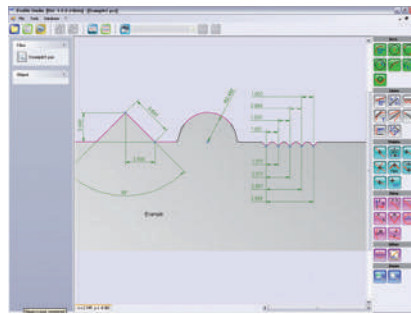

PROFILE STUDIO software

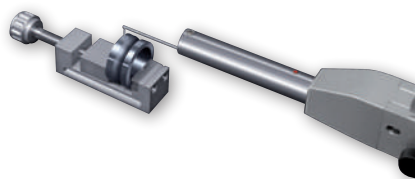
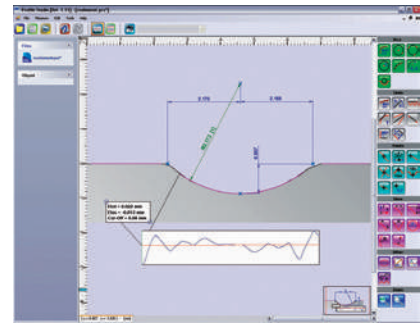

SB2000 probe

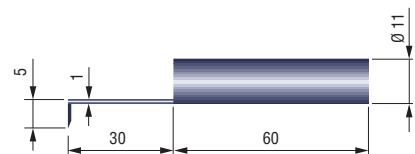

No

=

06960100 PROFILE SET 2 mm for profile measurement with RUGOSURF 90G

DELIVERED WITH THE FOLLOWING ACCESSORIES:

06960101 PROFILE STUDIO Software

06960102 SB2000 probe for PROFILE SET 2 mm, R = 15 μ m, 20°

06960103 Setting master for PROFILE SET 2 mm

06960062 Cable RUGOSURF 10G and RUGOSURF 90G to PC (connector v3)



RUGOSOFT Software

Software for RUGOSURF 20 and RUGOSURF 10G.

Enables the user to import stored measurement values from the device to the computer for the management of a database.

Optimal and detailed visualization of the results: parameters, profiles (R roughness and P primary profile) or a combination of both.

Calculation of roughness parameters.

Statistical analysis of a set of measurements.

Creation and storage of measuring programs (instrument parameters and parameters to be measured) in the software, which can then be loaded onto the instrument.

Customizable measurement report.

Output from the PC

- measuring results with measuring parameters
- profiles as coordinates
- measuring report in format: .xls .pdf .doc .rpt (Crystal Report) or also .rtf (Rich Text Format)

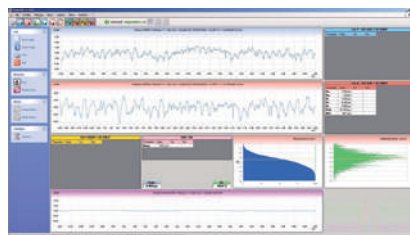

RUGOSOFT

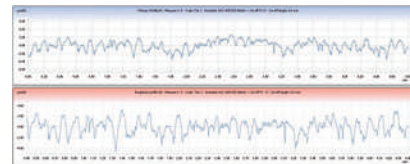

Roughness profile and primary profile

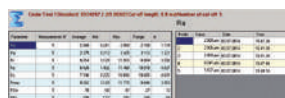

Statistics

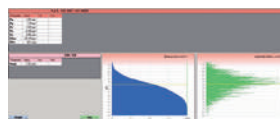

Parameters and bearing area curve

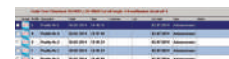

List of measurements



Included in delivery

| | | |
|-----------------|----------------------------|---|
| 06960034 | RUGOSOFT Software + Dongle | <ul style="list-style-type: none"> - USB protection key (dongle) - Installation CD - User instructions plus online support (included in the installation CD) |
|-----------------|----------------------------|---|

OPTIONAL ACCESSORIES:

| | |
|-----------------|--|
| 04760099 | Cable RUGOSURF 20 to PC |
| 06960062 | Cable RUGOSURF 10G and RUGOSURF 90G to PC (connector v3) |



MEASUREMENT STUDIO Software

Software for RUGOSURF 90G.

Enables the import of stored measurement data from the device to the computer, for processing in a database.

Optimal and detailed visualization of the results: parameters, profiles (W undulation, P primary profile and R roughness) or the three.

Calculation of roughness parameters including VDA parameters.

Statistical analysis of a set of measurements.

Creation and storage of measuring programs in the software, which can then be loaded onto the instrument.

Customizable measurement report.

Output from the computer

- measuring results with measuring parameters
- profiles as coordinates
- measuring report in format .xls .pdf .doc .rpt (Crystal Report) or .rft (Rich Text Format)



MEASUREMENT STUDIO

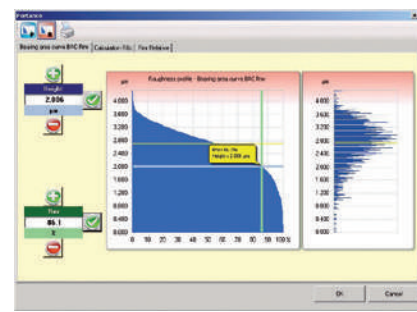

Bearing area curve

| Parameter | Measurements | Average | Min | Max | Range | St |
|-----------|--------------|---------|-------|--------|-------|-------|
| Pa | 3 | 2.521 | 0.828 | 2.114 | 3.306 | 0.983 |
| Pb | 3 | 2.843 | 0.942 | 3.517 | 2.976 | 1.268 |
| Pc | 3 | 5.995 | 3.294 | 11.954 | 7.638 | 3.521 |
| Pd | 3 | 2.905 | 1.137 | 4.126 | 2.879 | 1.262 |
| Pe | 3 | 6.186 | 2.288 | 4.889 | 4.811 | 2.022 |
| Pf | 3 | 8.187 | 3.467 | 11.817 | 7.966 | 3.215 |
| Pg | 3 | 4.821 | 1.263 | 10.276 | 9.314 | 3.969 |
| Ph | 3 | 0 | 0 | 0 | 0 | 0 |
| Pi | 3 | 8.985 | 4.214 | 11.954 | 7.528 | 3.227 |
| Pj | 3 | 0 | 0 | 0 | 0 | 0 |
| Pk | 3 | 3.179 | 0.828 | 3.216 | 2.087 | 1.100 |
| Pl | 3 | 2.883 | 0.828 | 3.822 | 2.827 | 1.200 |
| Pm | 3 | 5.951 | 4.438 | 10.262 | 2.987 | 2.629 |
| Pn | 3 | 2.985 | 1.795 | 5.524 | 3.289 | 1.471 |
| Po | 3 | 5.792 | 3.750 | 7.120 | 4.080 | 2.175 |
| Pp | 3 | 7.035 | 1.797 | 10.206 | 8.593 | 3.734 |
| Pq | 3 | 0 | 0 | 0 | 0 | 0 |
| Pr | 3 | 0.957 | 0.402 | 12.952 | 1.987 | 3.029 |
| Pt | 3 | 0 | 0 | 0 | 0 | 0 |
| Pu | 3 | 0 | 0 | 0 | 0 | 0 |
| Pv | 3 | 0 | 0 | 0 | 0 | 0 |
| Pw | 3 | 0 | 0 | 0 | 0 | 0 |
| Px | 3 | 0 | 0 | 0 | 0 | 0 |
| Py | 3 | 0 | 0 | 0 | 0 | 0 |
| Pz | 3 | 0 | 0 | 0 | 0 | 0 |
| Pa1 | 1 | 0.336 | 0.336 | 0.336 | 0.306 | 0.000 |
| Pa2 | 1 | 0.695 | 0.695 | 0.695 | 0.306 | 0.000 |
| Pa3 | 1 | 0.975 | 0.975 | 0.975 | 0.306 | 0.000 |
| Pa4 | 1 | 0.306 | 0.306 | 0.306 | 0.306 | 0.000 |
| Pa5 | 1 | 0.306 | 0.306 | 0.306 | 0.306 | 0.000 |
| Pa6 | 1 | 0.306 | 0.306 | 0.306 | 0.306 | 0.000 |
| Pa7 | 1 | 0.306 | 0.306 | 0.306 | 0.306 | 0.000 |
| Pa8 | 1 | 0.306 | 0.306 | 0.306 | 0.306 | 0.000 |
| Pa9 | 1 | 0.306 | 0.306 | 0.306 | 0.306 | 0.000 |
| Pa10 | 1 | 0.306 | 0.306 | 0.306 | 0.306 | 0.000 |
| Pa11 | 1 | 0.306 | 0.306 | 0.306 | 0.306 | 0.000 |
| Pa12 | 1 | 0.306 | 0.306 | 0.306 | 0.306 | 0.000 |
| Pa13 | 1 | 0.306 | 0.306 | 0.306 | 0.306 | 0.000 |
| Pa14 | 1 | 0.306 | 0.306 | 0.306 | 0.306 | 0.000 |
| Pa15 | 1 | 0.306 | 0.306 | 0.306 | 0.306 | 0.000 |
| Pa16 | 1 | 0.306 | 0.306 | 0.306 | 0.306 | 0.000 |
| Pa17 | 1 | 0.306 | 0.306 | 0.306 | 0.306 | 0.000 |
| Pa18 | 1 | 0.306 | 0.306 | 0.306 | 0.306 | 0.000 |
| Pa19 | 1 | 0.306 | 0.306 | 0.306 | 0.306 | 0.000 |
| Pa20 | 1 | 0.306 | 0.306 | 0.306 | 0.306 | 0.000 |

Statistics

| Pai VDA 2007 | | | |
|--------------|----------|------|------|
| Parameter | Value | Tol- | Tol+ |
| WDSm | 0.273 µm | | |
| WDC | 0.971 µm | | |
| WDT | 2.243 µm | | |

VDA parameters



Measuring report with customisable header and logo



06960048

MEASUREMENT STUDIO software + dongle for RUGOSURF 90G

Included in delivery

- USB protection key (dongle)
- Installation CD, 6 languages
- User instructions (included on the installation CD)
- USB connection cable to the PC for RUGOSURF 10G and RUGOSURF 90G, length 1,80 m



PROFILE STUDIO Software

For profile measurement using the RUGOSURF 90G.

Allows evaluation of micro and macro geometric characteristics of a surface.

Measurement programme creation that can be saved for the same measurements on a batch of identical parts from the same set or for subsequent batch measurements: it is possible to use all the dimensions and tolerances of a reference profile for a measurement of a batch of the same part.

Measurement instructions and help assistance for calibration controlled from the PC.

Import and export of measurement parameters from and to the device.

Storage of measurement results and of the measured parameters as database.

Database search with filters (date, operator, batch, etc.).

Detailed visualization of the measured profile and geometric construction tools (arc, line, point, intersection, angle, etc.).

Measurements reports with customizable header.

Languages: English, German, French, Spanish, Italian, Portuguese, Slovenian.

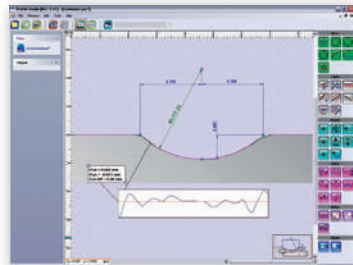

PROFILE STUDIO software

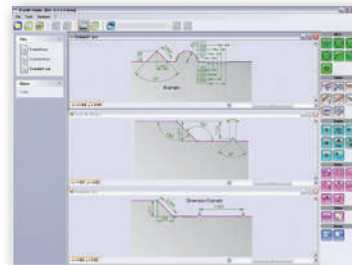

Measurement of geometric elements



No

=



Included in delivery

| | | |
|----------|-------------------------|---------------------------------|
| 06960101 | PROFILE STUDIO Software | CD with PROFILE STUDIO software |
|----------|-------------------------|---------------------------------|

OPTIONAL ACCESSORIES:

| | |
|----------|--|
| 06960102 | SB2000 probe for PROFILE SET 2 mm, R = 15 µm, 20° |
| 06960103 | Setting master for PROFILE SET 2 mm |
| 06960062 | Cable RUGOSURF 10G and RUGOSURF 90G to PC (connector v3) |

PROBES FOR TESA RUGOSURF

Standard probes for TESA RUGOSURF roughness gauges, available with different geometries and sizes according to the nature and type of surface being measured.

Standard Probes

Standard probes supplied with TESA surface roughness gauges and SB2000 probes for profile measurement

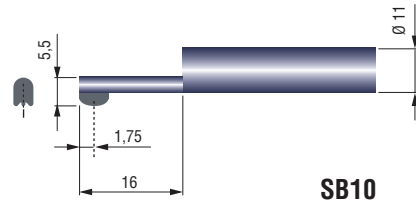

SB10

SB10 probe

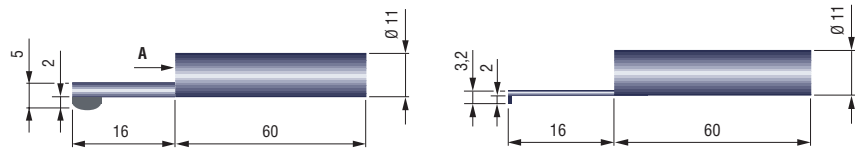

SB60/10 probe with removable skid for RUGOSURF 90G

SB2000 probe without skid

| No | = |
|----------|--|
| 06960036 | SB10 standard probe for RUGOSURF 20 and 10G R = 5 µm, 90° |
| 06960049 | SB60/10 standard probe fur RUGOSURF 90G R = 5 µm, 90° detachable skid |

Unless otherwise stated, 90° diamond tip, radius R = 5 µm



Optional Probes for RUGOSURF 20 and 10G

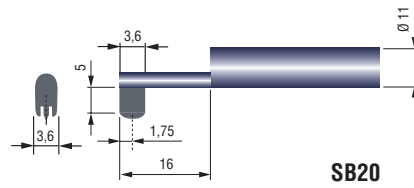

SB20

06960037

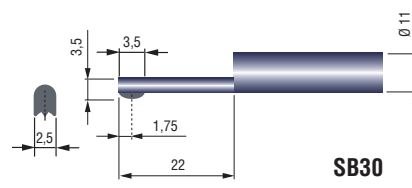

SB30

06960038

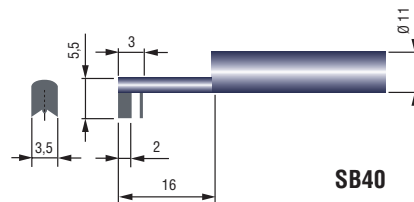

SB40

06960039

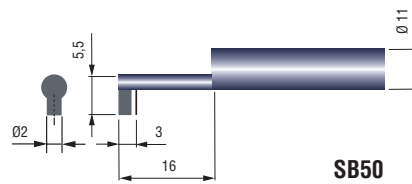

SB50

06960040

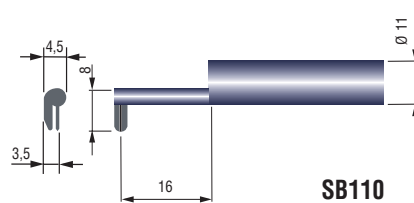

SB110

06960057

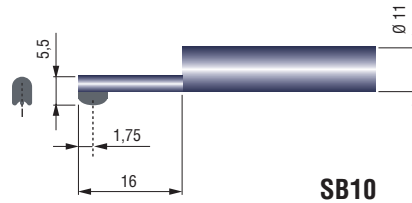

SB10

06960081 SB10 but R = 2 μm

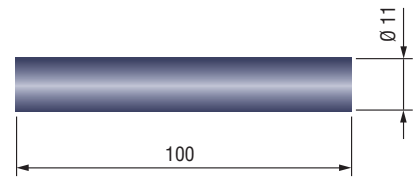

06960056

| No | ≡ |
|----------|--|
| 06960037 | SB20 probe for RUGOSURF 20 et 10G for grooves of depth < 5 mm |
| 06960038 | SB30 probe for RUGOSURF 20 and 10G for small bores of $\varnothing > 4$ mm |
| 06960039 | SB40 Probe for RUGOSURF 20 and 10G V-shape for cylinders of $\varnothing > 1$ mm |
| 06960040 | SB50 probe for RUGOSURF 20 and 10G for concave surfaces and for measuring at 90° with RUGOSURF 10G |
| 06960057 | SB110 probe for RUGOSURF 20 and 10G for concave or convex surfaces, R > 5 mm |
| 06960081 | Probe SB10 2μm for RUGOSURF 20 and 10G as SB10 but R = 2 μm |
| 06960056 | 100 mm extension for probe with skid for RUGOSURF 20, 10G, 90G |

Unless otherwise stated, 90° diamond tip, radius R = 5 μm



Optional Probes for RUGOSURF 90

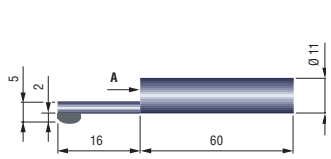

06960067

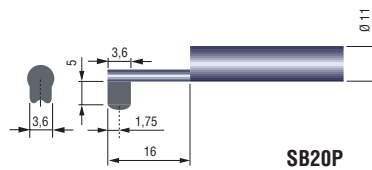

06960050

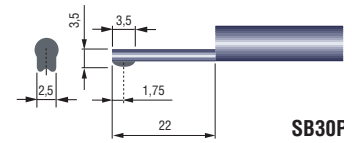

06960051

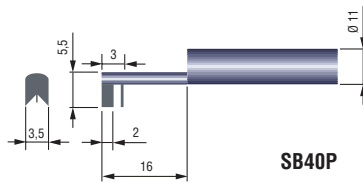

06960052

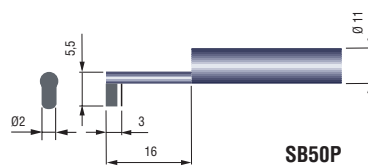

06960053

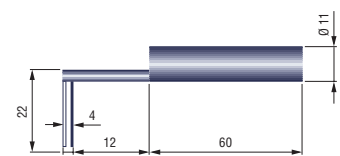

06960054

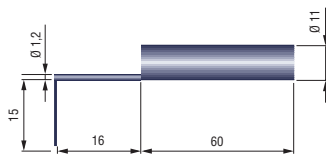

06960058

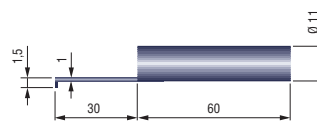

06960061

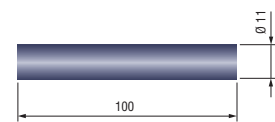

06960056



| | |
|----------|--|
| 06960067 | SB60/10 2µm probe for RUGOSURF 90G as SB60/10 but R = 2 µm |
| 06960050 | SB20P probe for RUGOSURF 90G for grooves of depth < 5 mm |
| 06960051 | SB30P probe for RUGOSURF 90G for small bores with $\varnothing > 4$ mm |
| 06960052 | SB40P probe for RUGOSURF 90G V-shape for cylinders with $\varnothing > 1$ mm |
| 06960053 | SB50P probe for RUGOSURF 90G for concave surfaces and for measuring at 90° with RUGOSURF 90G |
| 06960054 | SB120P probe for RUGOSURF 90G for grooves of depth < 20 mm |
| 06960058 | SB120S probe without skid for RUGOSURF 90G for grooves of depth < 15 mm |
| 06960061 | SB60-D2-L30 probe, L = 30 mm for RUGOSURF 90G for small bores of $\varnothing > 2$ mm |
| 06960056 | 100 mm extension for probe with skid for RUGOSURF 20, 10G, 90G |

Unless otherwise stated, 90° diamond tip, R = 5 µm



DOT MATRIX PRINTER FOR RUGOSURF

Dot matrix printer for TESA RUGOSURF portable roughness gauges and with built-in batteries, which enable the printing of measured parameters and roughness profiles regardless of the environment and the conditions.

It is also possible to print stored measurements data from the instrument memory.

PR Dot Matrix Printer

Dot matrix printer for TESA RUGOSOFT roughness gauges.

For printing measured parameters, and roughness profiles.

Also for printing measurement data saved in the instrument memory.



PR dot matrix portable printer for RUGOSURF

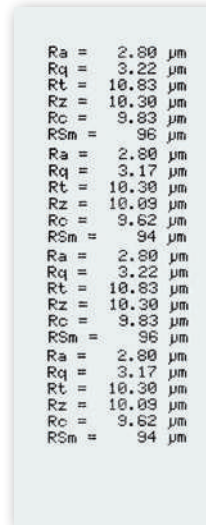

Roughness parameters measured

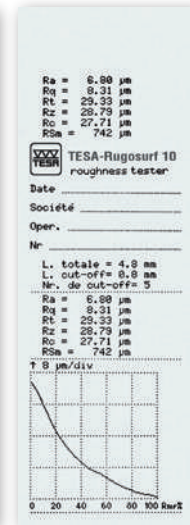

Measuring results and graphics with header

Roughness profile

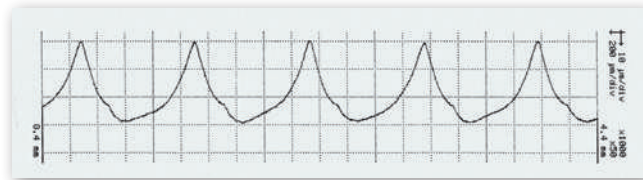

| No | = | Characteristics | Dimensions L x W x H, mm | Weight, g | Included in delivery |
|----------|-------------------------------|----------------------------------|--|----------------------|--|
| 06960033 | Printer for RUGOSURF + cables | Print-out of measured parameters | 165 x 120 x H100 mm (6.50 x 4.72 x H3.94 in) | 760 g (only printer) | <ul style="list-style-type: none"> - Printer - Cables for connection to the RUGOSURF - Ink ribbon - Roll of paper - Rechargeable battery - User instructions - Transport case |

DELIVERED WITH THE FOLLOWING ACCESSORIES:

| | |
|--------|--|
| 056109 | Connecting cable RUGOSURF 10G and RUGOSURF 90G to dot matrix printer |
| 058213 | Connecting cable RUGOSURF 20 to dot matrix printer |



Accessories for PR Dot Matrix Printer

Ink ribbon for printer

Paper roll

Battery

Transport case



06960044

No

=

06960043

Set of 3x ink ribbons for dot matrix printer

06960044

Set of 10 paper rolls
size 57 mm for dot matrix printer

056133

Power supply 100 ÷ 240 V, 50 ÷ 60 Hz, 0,5 Ah,
Output 9 V DC, max. 18 W, 5,5 mm connector
with EU and US adapter,
for PR dot matrix printer

056223

Transport case with foam for internal protection
of PR dot matrix printer



ACCESSORIES FOR TESA RUGOSURF, PROFILE SET 2 MM

Accessories for TESA RUGOSURF surface roughness testers, including Ra roughness specimens, granite bases with measuring supports, vertical supports for positioning, etc.

Other Accessories for RUGOSURF

External control for RUGOSURF 10G or 90G

Fixing pin Ø 8mm for universal support for RUGOSURF 20 ou 10G

Vertical positioning supports for RUGOSURF 20 or 10G

Probe holder for RUGOSURF 90G



06960042

| No | = |
|----------|---|
| 056631 | Adjustable vertical positioning supports (2 parts) V-form for cylinder Ø > 100 mm for RUGOSURF 10G |
| 057655 | Vertical and adjustable positioning supports (2 parts) V-form for cylinder Ø > 100 mm for RUGOSURF 20 |
| 056633 | Fixing pin Ø 8 mm for universal support for RUGOSURF 20 and 10G |
| 056641 | Probe holder with two positions – blocked position for measuring with a probe without skid – free position for measuring with a probe with skid for RUGOSURF 90G |
| 06960042 | External control for RUGOSURF 10G and 90G |
| 06960059 | External control with PR dot matrix printer cable for RUGOSURF 10G and 90G |

Chargers and Rechargeable Batteries



06960045

| No | = |
|----------|--|
| 06960045 | Battery NiMH 7,2 V, 300 mAh, format PP3, for RUGOSURF 20 et 10G |
| 056224 | Battery NiMH 12 V, 1800 mAh, for RUGOSURF 90G |
| 06960046 | Charger and power supply 100 ÷ 240 VAC, 50 ÷ 60 Hz, 12 V, 400 ÷ 600 mAh with EU and US adapter for RUGOSURF 20 and 10G |
| 056639 | Charger and power supply 100 ÷ 240 VAC, 50 ÷ 60 Hz, 18 V, 2,2 Ah with EU and US adapter for RUGOSURF 90G |



Granite Bases with Measuring Support for RUGOSURF

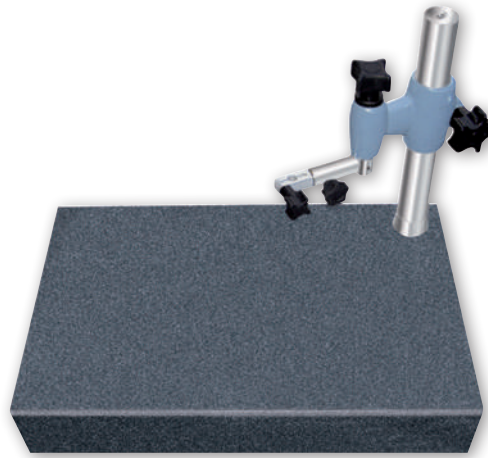

Granite base with measuring support for RUGOSURF 20 or 10G



Granite base with measuring support for RUGOSURF 90G with manual vertical positioning device

No

=

06960035

Granite 400 x 250 mm with vertical support H 150 mm,
25 kg, Grade 0 f
or Rugosurf 20 and 10G

06960055

Granite 630 x 400 mm with measuring support and manual vertical
positioning device H250mm, 60 kg, Grade 0
for RUGOSURF 90G



Ra Roughness Standards

As per EN ISO 5436-1 standard

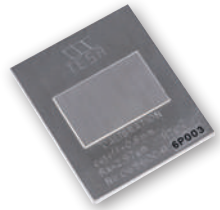

Standard Ra = 2,97 μm

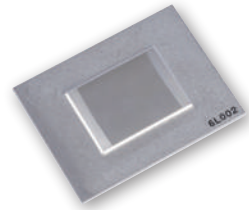

Standard Ra = 1,00 μm



Standard Ra = 0,50 μm



Standard Ra = 0,10 μm

| No | = |
|----------|--|
| 06960041 | Roughness standard Ra = 2,97 μm (117 μin) |
| 06960066 | Roughness standard Ra = 1,0 μm (40 μin) |
| 06960065 | Roughness standard Ra = 0,5 μm (20 μin) |
| 06960064 | Roughness standard Ra = 0,1 μm (4 μin) |

Setting Standard for PROFILE SET

For profile measurement

| No | = |
|----------|-------------------------------------|
| 06960103 | Setting master for PROFILE SET 2 mm |



RUGOTEST Roughness Comparison Specimens

For tactile and visual comparison of the workpiece surface finish according to various machining processes.

The specimen sets are according to individual machining processes.

ISO 2632-1 and 2632-2



ISO 2632
Parts 1 and 2

Rust-resistant
nickel

Specimens for
roughness com-
parison cannot be
used as reference
ones. Therefore, they
are not suitable for
calibrating surface
roughness testers.

Leather case

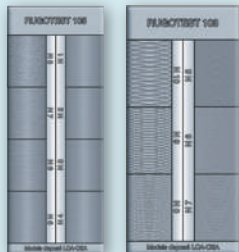

| No | = | | | | | | |
|-----------|--|----------------|----------------------|--------------------------------|------------------------|-----|---|
| | | RUGOTEST N° | Number of samples | ISO roughness parameters | Dimen- sions, mm | g | Included in delivery |
| 081112053 | RUGOTEST 1 | 1 | 27 | M1 - N10 | 135 x 105 | 160 | Side milling (3 specimens), N8-N9-N10; Face milling (5 specimens), N6-N7-N8-N9-N10; Turning/Planing (5 specimens), N6-N7-N8-N9-N10; Grinding (6 specimens), N2-N3-N4-N5-N6-N7; Lapping (4 specimens), N2-N3-N4-N5; Finish grinding / honing (4 specimens), N1-N2-N3-N4 |
| 081112054 | RUGOTEST 2 | 2 | 16 | N6 - N11 | 120 x 90 | 160 | |
| 081112055 | RUGOTEST 3 | 3 | 18 | N6 - N11 | 120 x 90 | 190 | With samples for shot blasting, spherical coarse grains (3 specimens), N9-N10-N11; With samples for shot blasting, spherical fine grains (6 specimens), N6-N7-N8-N9-N10-N11; With samples for shot blasting, angular coarse grains (3 specimens), N9-N10-N11; With samples for shot blasting, angular fine grains (6 specimens), N6-N7-N8-N9-N10-N11 |
| 081112056 | RUGOTEST 4 | 4 | 6 | N6 - N8 | 120 x 90 | 160 | Straight filing (3 specimens), N6-N7-N8; Cross filing (3 specimens), N6-N7-N8 |
| 081112057 | RUGOTEST 5 | 5 | 10 | N0 - N4 | 120 x 90 | 200 | Surface cylindrical form (5 specimens), N0-N1-N2-N3-N4; Surface flat form (5 specimens), N0-N1-N2-N3-N4; |
| 081112058 | RUGOTEST 101 Sanding | 101 | 6 | N6 - N11 | 110 x 50 | 110 | |
| 081112059 | RUGOTEST 102 Turning | 102 | 6 | N5 - N10 | 110 x 50 | 105 | |
| 081112060 | RUGOTEST 103 Face milling | 103 | 6 | N5 - N10 | 110 x 50 | 110 | |
| 081112061 | RUGOTEST 104 | 104 | 8 | N1 - N8 | 130 x 50 | 125 | |
| 081112062 | RUGOTEST 105 Circular grinding | 105 | 8 | N1 - N8 | 130 x 50 | 130 | |
| 081112063 | RUGOTEST 107 Spark erosion | 107 | 6 | N5 - N10 | 110 x 50 | 110 | |
| 081112344 | RUGOTEST Spark erosion | 12 | 12 | Charmilles 12 to 45 | 127 x 27 | 60 | |
| 081112346 | RUGOTEST A4 Set of 4 sets of sur- face specimens with RUGOTEST 1, 2, 3 and 4 | | | | 330 x 250 | 710 | |
| 081112345 | RUGOTEST A6 Set of 6 sets of sur- face specimens with RUGOTEST 101, 102, 103, 104, 105, 107 | | | | 330 x 250 | 780 | |



| ISO Roughness Parameters | Roughness Ra μm (μin) | Charmilles Roughness Parameters (VDI 3400) | Roughness Ra μm |
|--------------------------|---|--|----------------------------|
| N0 | 0,0125 (0.5) | 12 | 0,40 |
| N1 | 0,025 (1) | 15 | 0,56 |
| N2 | 0,05 (2) | 18 | 0,80 |
| N3 | 0,1 (4) | 21 | 1,12 |
| N4 | 0,2 (8) | 24 | 1,60 |
| N5 | 0,4 (16) | 27 | 2,24 |
| N6 | 0,8 (32) | 30 | 3,15 |
| N7 | 1,6 (63) | 33 | 4,5 |
| N8 | 3,2 (125) | 36 | 6,3 |
| N9 | 6,3 (250) | 39 | 9,0 |
| N10 | 12,5 (500) | 42 | 12,5 |
| N11 | 25,0 (1000) | 45 | 18,0 |



ISO 2632 Parts 1 and 2



Rust-resistant nickel



The comparison specimens are not roughness standards. They should not be used for the calibration of surface roughness instruments



Leather case



Height Gauges



INSPECTION DURING THE COURSE OF THE MANUFACTURING PROCESS

Height gauges are single-axis handtools made to measure on a surface plate, preferably on granite. The TESA- μ HITE version being offered in this section clearly shows that combining a surface plate with any height gauge can create a complete measuring system.

Providing the necessary versatility, they are well suited for dimensional inspection directly on a machine or a group of machines, usually during the various setting and sampling operations throughout the whole manufacturing process.

They are specially made for checking parts that are difficult to machine due to their critical sizes.

TESA-HITE or TESA MICRO-HITE, whether manually operated or motor-driven, do not require any special skills. Nearly everyone working in the workshop can use them easily.



SCS Calibration Certificate

The newly implemented TESA-HITE and TESA MICRO-HITE production line now also includes its own temperature-controlled laboratory recently certified by the Swiss Accreditation Service (SCS), so that each height gauge comes with a SCS calibration certificate provided free of charge.

The negligible temperature variation ($20^{\circ}\text{C} \pm 0,1^{\circ}$) along with the use of high-precision step gauges allow the lowest uncertainty of measurement to be achieved during the calibration process.

As a first step, all values needed for automatic compensation for the systematic errors of the finished height gauge through Computer Aided Accuracy (CAA) are captured.

Once conveniently calculated, each single compensation value is then stored in the tool memory so as to allow the automatic calculation of the measured values during calibration.

Finally, the relevant calibration certificate is issued based on the values obtained during a new series of measurements taken at another measuring station, also equipped with step gauges. The applied calibration procedure together with the SCS based certification ensure that every TESA height gauge is traceable to national standards.

Height Gauges – One of TESA's Strengths

TESA offers the largest range of height gauges for reliable one or two-dimensional measurements. End users can choose the most suitable model not only according to the requirements of their metrology applications, but also according to their financial resources.

This wide range goes from the simple height and scribing gauge to the motorised vertical column suitable for high-precision measurements in two coordinate directions.

















| |  |  |  | 1D |  |  |  | 2D |  | Motorized |
|---|---|---|---|----|---|--|---|----|---|-----------|
| Height Gauges | µm (L in m) | Standard Accessory (mm) | Special Accessory (mm) | | | | | | | |
|  TESA-HITE Magna | 8 | 870 | 1095 | • | • | | | | | |
|  TESA-HITE | 2,5 + 4L | 870 | 1095 | • | • | • | | | | |
|  TESA-HITE plus M | 2,5 + 3L | 860 | 1085 | • | • | • | • | • | • | • |
|  TESA MICRO-HITE | 2 + 3L | 1075 | 1300 | • | • | • | • | • | | |
|  TESA MICRO-HITE plus M | 1,9 + 1,5L | 1075 | 1300 | • | • | • | • | • | • | • |
|  TESA-µHITE | 1 or 2 | 160 | 360 | • | • | | | | | • |
|  TESA-µHITE + POWER PANEL plus M | 1 or 2 | 160 | 360 | • | • | | • | • | • | • |
|  ETALON height and scribing gauges | 40 | 1000 | - | • | | | | | | |



TESA-HITE Magna 400 and 700

Conceived using well-proven TESA technology, both the TESA-HITE magna 400 and 700 models are equipped with the TESA patented magna μ measuring system and can be used in the harshest workshop conditions, especially where the gauges are exposed to splashing liquids of any kind and the penetration of dust particles. Their unique characteristics means that the gauges offer the most favourable price/performance ratio found in the market and constitute an essential tool in the workshop. Robust and reliable, their futuristic design guarantees maximum strength when used near production machines. Each height gauge is provided with a rechargeable battery and can be used to measure height or step dimensions as well as diameters, centre to centre distance of bores or grooves, the size of grooves and much more.

- Wide application range, two sizes available with measuring span to 415 mm/ 16 in or 715 mm/28 in, respectively.
- Electronics totally protected against oil and water splashing or dust particles (IP65).
- Control panel with numerical display to 0,001 / 0,005/0,01 mm or 0,0001/0.0002/ 0.001 in.
- Dynamic probing of the workpiece with a constant measuring force.
- Easiness, high reliability when checking bores or shafts using TESA's unique device for automatic detection of the culmination point – patented.
- Acoustic signal to acknowledge value capture, also conveniently programmable.
- Ability to measure parallelism errors.
- TESA's magnetic system, guaranteeing correct operating even in harsh workshop conditions – patented.
- Large LC display, also with symbols for the measuring functions.
- Zero-setting anywhere within the measuring range.
- PRESET function for entering any given value.
- Metric/inch conversion.
- RS 232 data output.
- SCS calibration certificate provided with each height gauge.

-  Factory standard
-  83 x 49 mm LC display, 7-decade plus minus sign. Also with graphical symbols for all active functions.
-  0,001 / 0,005 / 0,01 mm or 0.0001 / 0.0002 / 0.001 in
-  12 mm
-  Magnetic scale
-  Metric/Inch conversion
-  Nickel plated gauge base (chemical coating)
-  1,5 ± 0,5 N (at switch point)
-  500 mm/s 20 in/s
-  Measuring span, application range and precision: see relevant table on page N-5.
-  Probing head mounted on a ball-bearing, hand wheel for head displacement, fine setting. Head drive carriage can be locked.
-  RS232
-  Rechargeable batteries, 6V
-  ~ 60 h



- $(12 \pm 1,5) \times 10^{-6} K^{-1}$
- 10°C to 40°C
- 10°C to 60°C
- 100 %
- IP55 or IP65 for both electronics and measuring system (IEC 60529)
- EN 61326, Class B (with disconnected charger)
- See table
- Shipping packaging
- Identification number
- Declaration of conformity
- SCS calibration certificate

| No | = | | |
|------------------------------|---|------------|------------|
| | | mm | in |
| 00730047 | Height gauge TESA-HITE magna 400 | 415 | 16 |
| 00730059 | Height gauge TESA-HITE magna 700 | 715 | 28 |
| CONSISTING OF: | | 400 | 700 |
| 00760143 | Standard probe insert holder | ● | ● |
| 00760157 | Rechargeable battery, 6V | ● | ● |
| 00760164 | Standard probe insert with 5mm dia. tungsten carbide ball tip | ● | ● |
| 00760231 | Master piece for establishing the probe constant, nominal dimension 6,350 mm / 0.250 in | ● | ● |
| 04761054 | Mains adapter 100 ÷ 200 VAC / 50 ÷ 60 Hz | ● | ● |
| 04761055 | Cable EU for mains adapter | ● | ● |
| 04761056 | Cable US for mains adapter | ● | ● |
| OPTIONAL ACCESSORIES: | | | |
| 04761052 | Extension cable, Sub-D 9p/f to 9p/m, 2 m | | |
| 04761063 | Sub-D 9p/m to USB cable, 2 m | | |

Technical Data

| Models | TESA-HITE magna | | |
|---|--|----------|----------|
| | 400 | 700 | |
| | mm | 415 | 715 |
| | in | 16 | 28 |
| With standard accessory | mm | 0 ÷ 570 | 0 ÷ 870 |
| | in | 0 ÷ 22 | 0 ÷ 34 |
| With probe insert holder No. 00760057 | mm | 0 ÷ 625 | 0 ÷ 925 |
| | in | 0 ÷ 24 | 0 ÷ 36 |
| With probe insert holder No. S07001622 | mm | 0 ÷ 795 | 0 ÷ 1095 |
| | in | 0 ÷ 31 | 0 ÷ 43 |
| With standard accessory | µm | < 8 | < 8 |
| | in | < 0.0003 | < 0.0003 |
| With standard accessory | On flat surfaces: 2σ = < 3µm / < 0.00015 in | | |
| | Into bores: 2σ = < 5µm / < 0.00020 in | | |
| | kg | 15 | 18 |



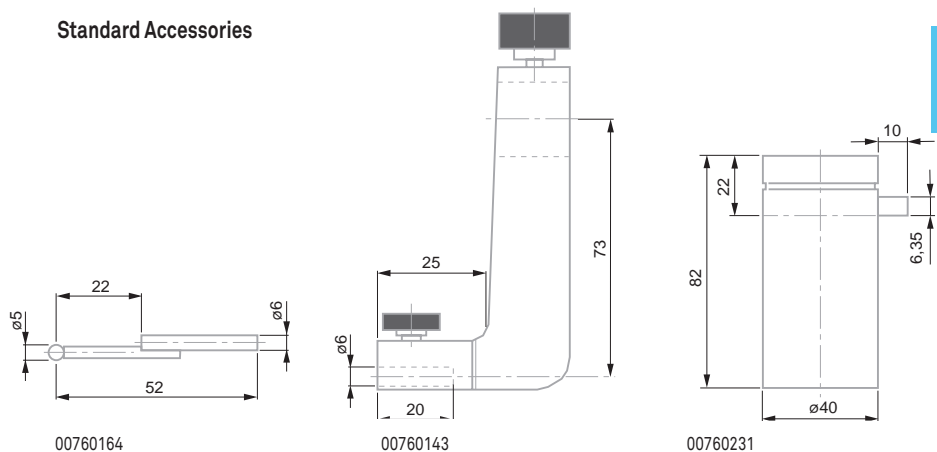

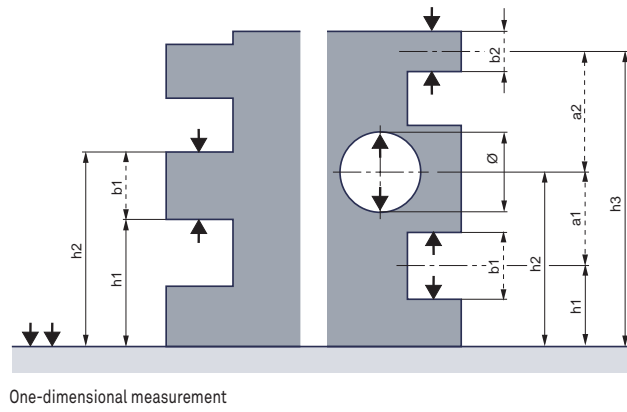
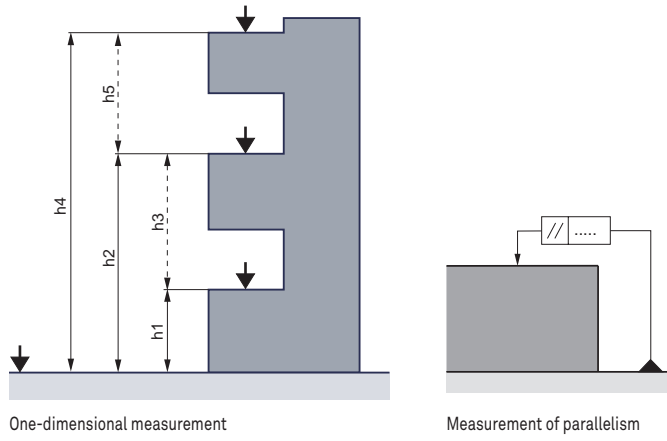









Standard Accessories





One-dimensional measurement



-  Factory standard
-  83 x 49 mm LC display. 7-decade plus minus sign. Also with graphical symbols for all active functions.
-  0,0001 / 0,001 / 0,01 mm or 0,00001 / 0,0001 / 0,001 in
-  12 mm
-  Incremental glass scale, opto-electronic
-  mm/in conversion
-  Frontal, model 400 <math>< 9 \mu\text{m}</math>, model 700 <math>< 13 \mu\text{m}</math>
-  Nickel plated gauge base (chemical coating) with bottom face including 3 resting points, finely lapped.
-  1,5 ± 0,5 N (at switch point)
-  500 mm/s 20 in/s
-  Air-cushion for easy displacement over the surface plate. Measuring span, application range and precision: see table on page N-8.
-  Probing head mounted on a ball-bearing, hand wheel for head displacement, fine setting. Head drive carriage can be locked.
-  RS232
-  Rechargeable batteries, 6V
-  ≈ 60 h

TESA-HITE 400 / 700

By their robustness and reliability, the TESA-HITE 400 and 700 provided with its optoelectronic incremental rule (TESA patented) measurement system are ideally suited for applications in the workshop.

Their battery power gives them full autonomy.

Each version allows, among other things, the entry height dimensions or staged, the diameter, the distance between two grooves or two holes and groove width.

- Integrated air-bearing for easy displacement across the granite plate.
- Electronics totally protected against oil and water splashing, dust particles (IP65).
- Control panel with numerical display to 0,0001 / 0,001 / 0,01 mm or 0.00001 / 0.0001 / 0.001 in.
- Dynamic probing of the workpiece with a constant measuring force.
- Easiness, high reliability when checking bores or shafts using TESA's unique device for automatic detection of the culmination point – patented.
- Acoustic signal to acknowledge value capture, also conveniently programmable.
- Ability to measure any deviation in parallelism.
- Possible use of a digital sensor for determining perpendicularity errors with stated angle of the linear regression line.
- Patented TESA's opto-electronic system. Long-lasting stability of the glass scale for unbroken high accuracy.
- Large LC display with symbols for the measuring functions.
- Zero-setting anywhere within the measuring range.
- PRESET function for entering any given value.
- Metric/inch conversion.
- RS 232 data output.
- SCS calibration certificate provided with each height gauge.



| 00730043 | TESA-HITE 400 | 415 | 16 |
|------------------------------|---|------------|------------|
| 00730044 | TESA-HITE 700 | 715 | 28 |
| CONSISTING OF: | | 400 | 700 |
| 00760143 | Standard probe insert holder | ● | ● |
| 00760157 | Rechargeable battery, 6V | ● | ● |
| 00760219 | Master piece for establishin the probe constant, nominal dimension to 6,350 mm / 0.250 in | ● | ● |
| 00760226 | Electric pump for creating the air-cushion beneath the gauge base, already mounted | ● | ● |
| 00760227 | Standard probe insert with shank and 5 mm dia. ball tip in tungsten carbide | ● | ● |
| 04761054 | Mains adapter 100 ÷ 200 VAC / 50 ÷ 60 Hz | ● | ● |
| 04761055 | Cable EU for mains adapter | ● | ● |
| 04761056 | Cable US for mains adapter | ● | ● |
| OPTIONAL ACCESSORIES: | | | |
| 04761052 | Extension cable, Sub-D 9p/f to 9p/m, 2 m | | |
| 04761063 | Sub-D 9p/m to USB cable, 2 m | | |
| 04760070 | RS port, used to connect a digital sensor for perpendicularity measurement | | |

- $(12 \pm 1,5) \times 10^{-6} K^{-1}$
- 10 °C to 40 °C
- 10 °C to 60 °C
- 80 %, non-condensing
- IP40, electronics to IP65 (IEC 60529)
- EN 61326, Class B (with disconnected charger)
- See table opposite
- Shipping packaging
- Identification number
- Declaration of conformity
- SCS calibration certificate

Technical data

| | Models | | TESA-HITE 400 | TESA-HITE 700 |
|--|--|-------------------------|------------------------------------|---------------|
| | | mm | 415 | 715 |
| | | in | 16 | 28 |
| | With standard accessory | mm | 0 ÷ 570 | 0 ÷ 870 |
| | | in | 0 ÷ 22 | 0 ÷ 34 |
| | With probe insert holder No. 00760057 | mm | 0 ÷ 625 | 0 ÷ 925 |
| | | in | 0 ÷ 24 | 0 ÷ 36 |
| | With probe insert holder No. S07001622 | mm | 0 ÷ 795 | 0 ÷ 1095 |
| | | in | 0 ÷ 31 | 0 ÷ 43 |
| | With standard accessory | µm | (2,5 + 4 L) µm (L in m) | |
| | | in | (0.0001 + 0.000004 L) in (L in in) | |
| | With standard accessory | On flat surfaces: | | |
| | | 2σ < 2 µm / < 0.0001 in | | |
| | | Into bores: | | |
| | 2σ < 3 µm / < 0.00015 in | | | |
| | Frontal, mechanical | µm | 9 | 13 |
| | | in | 0.00035 | 0.0005 |
| | | kg | 27 | 32 |

Standard Accessories

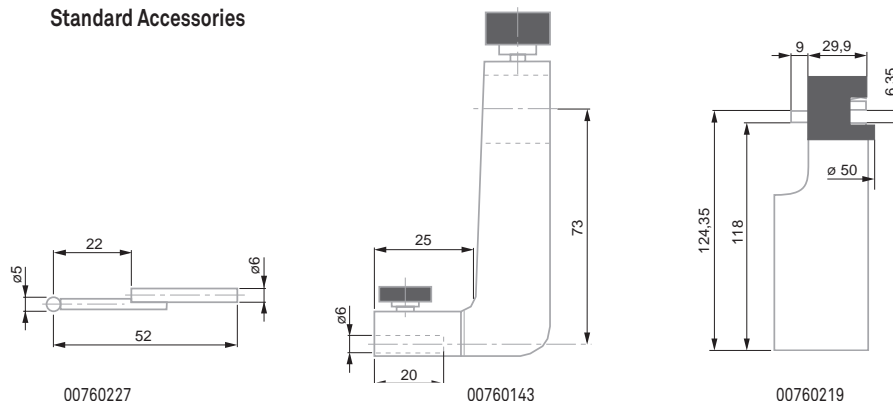

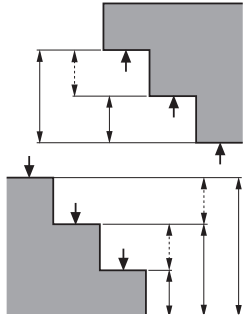

One-dimensional measurement

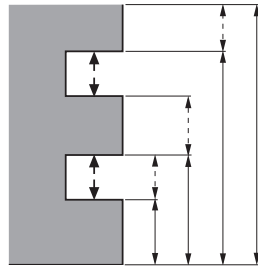

One-dimensional measurement

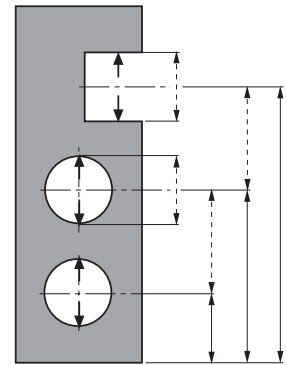

One-dimensional measurement

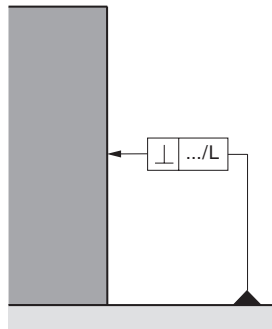

Perpendicularity measurement

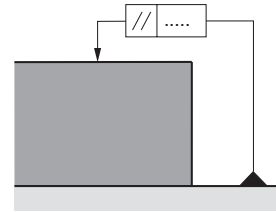

Parallelism measurement

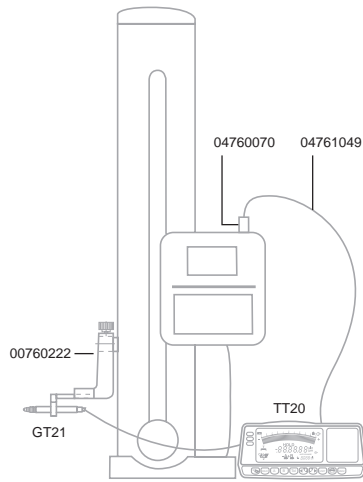

Configuration for perpendicularity measurement

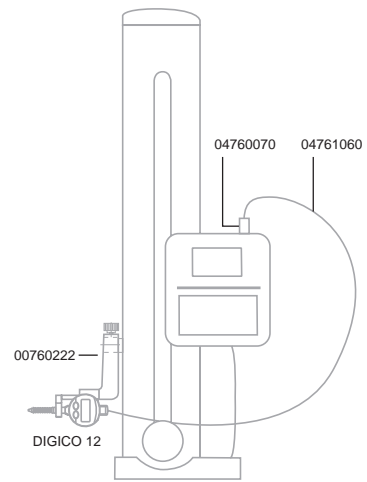

Configuration for perpendicularity measurement



TESA-HITE Plus M 400 / 700

The added value of the motorised TESA-HITE plus M 400 / 700 is not only noticeable in their technical features, but also in their ease of use. Combine with the programming function, this solution is ideal for recurrent measurements in the shop floor environment.

Advanced functions allow for complex calculations such as those required for two-axis or perpendicularity measurement. These height gauges with outstanding features offer the most attractive price/performance relationship, making them indispensable for the workshop.

- Wide application range.
- Electronics entirely protected from the penetration of liquids and dust particles.
- Integrated air cushion, mounted control panel.
- Easy, intuitive use of the rotary power control.
- Provide all the measuring functions of a dedicated motorised column, including height, diameter, distance, parallelism, perpendicularity, straightness, angle and 2D measurement besides programming, automatic probing cycles, statistical value processing.
- TESA's patented measuring system, opto-electronic.
- Probe insert holder and inserts compatible with those of TESA MICRO-HITE.
- SCS calibration certificate attached to each height gauge.



- Factory standard
- Dual LC display, 128 x 63 mm in size.
- Dual LC display, 128 x 63 mm in size.
 - Upper display field for length values (7 segments/sign) also with symbols for the functions.
 - Lower full dot display field for perpendicularity and straightness along with symbols for all operator-controlled function keys.
 - 7 segment display plus minus sign for the measured values
- 0,0001 / 0,001 / 0,01 mm or 0.00001 / 0.0001 / 0.001 in
- Incremental glass scale, opto-electronic data capture
- Main display with a size to 12,7 x 6,4 mm or 6,3 x 4,2 mm for auxiliary display
- Frontal for models 400 = < 8 µm 700 = < 12 µm
- Rugged nickel plated gauge base having 3 resting points, finely lapped.
- 1 N. Coupled servomotor for triggering the measuring force.
- Air bearing for easy displacement on the granite plate. For measuring span, application range and precision: see the table on page N-11. 30 function keys available on the keyboard.
- Measuring head mounted on a ball-bearing. Electro-motorised head displacement at varying speeds from 7,5 up to 40 mm/s. Manual displacement: ≤ 600 mm/s. Automatic value acquisition with a constant measuring force.
- RS232
- Rechargeable batteries, 6V
- ≈ 60 h, full charging takes 8 hours



- $(12 \pm 1,5) \times 10^{-6} \text{ K}^{-1}$
- 10 °C to 40 °C
- 10 °C to 60 °C
- 80 %, non-condensing
- IP40, IP65 for the electronic control panel (IEC 60529)
- EN 61326, class B (with disconnected battery charger)
- See table opposite
- Shipping packaging
- Identification number
- Declaration of conformity
- SCS calibration certificate

| No | | | |
|------------------------------|---|------------|------------|
| 00730045 | TESA-HITE plus M 400 | 405 | 16 |
| 00730046 | TESA-HITE plus M 700 | 705 | 27 |
| 00730057 | TESA-HITE plus M 400 + printer | 405 | 16 |
| 00730058 | TESA-HITE plus M 700 + printer | 705 | 27 |
| CONSISTING OF: | | 400 | 700 |
| 00760143 | Standard probe insert holder | ● | ● |
| 00760157 | Rechargeable battery, 6V | ● | ● |
| 00760219 | Master piece for establishin the probe constant, nominal dimension to 6,350 mm / 0.250 in | ● | ● |
| 00760226 | Electric pump for creating the air-cushion beneath the gauge base, already mounted | ● | ● |
| 00760227 | Standard probe insert with shank and 5 mm dia. ball tip in tungsten carbide | ● | ● |
| 04761054 | Mains adapter 100 ÷ 200 VAC / 50 ÷ 60 Hz | ● | ● |
| 04761055 | Cable EU for mains adapter | ● | ● |
| 04761056 | Cable US for mains adapter | ● | ● |
| OPTIONAL ACCESSORIES: | | | |
| 04760070 | RS port, used to connect a digital sensor for perpendicularity measurement | | |
| 04761052 | Extension cable, Sub-D 9p/f to 9p/m, 2 m | | |
| 04761063 | Sub-D 9p/m to USB cable, 2 m | | |
| 04765008 | Thermal paper 57 MM | | |

Technical Data

| | Models | | TESA-HITE plus M 400 | TESA-HITE plus M 700 |
|--|--|----|--|----------------------|
| | | mm | 405 | 705 |
| | | in | 16 | 27 |
| | With standard accessory | mm | 0 ÷ 560 | 0 ÷ 860 |
| | | in | 0 ÷ 22 | 0 ÷ 33 |
| | With probe insert holder No. 00760057 | mm | 0 ÷ 615 | 0 ÷ 915 |
| | | in | 0 ÷ 24 | 0 ÷ 35 |
| | With probe insert holder No. S07001622 | mm | 0 ÷ 785 | 0 ÷ 1085 |
| | | in | 0 ÷ 31 | 0 ÷ 42 |
| | With standard accessory | µm | (2,5 + 3 L) µm (L in m) | |
| | | in | (0.0001 + 0.000003 L) in (L in in) | |
| | With standard accessory | | On flat surfaces: 2 σ = < 1 µm / < 0.00005 in | |
| | | | Into bores: 2 σ = < 2 µm / < 0.0001 in | |
| | Frontal, mecanical | µm | 8 | 12 |
| | | in | 0.00031 | 0.00047 |
| | | kg | 27 | 32 |

Standard Accessories

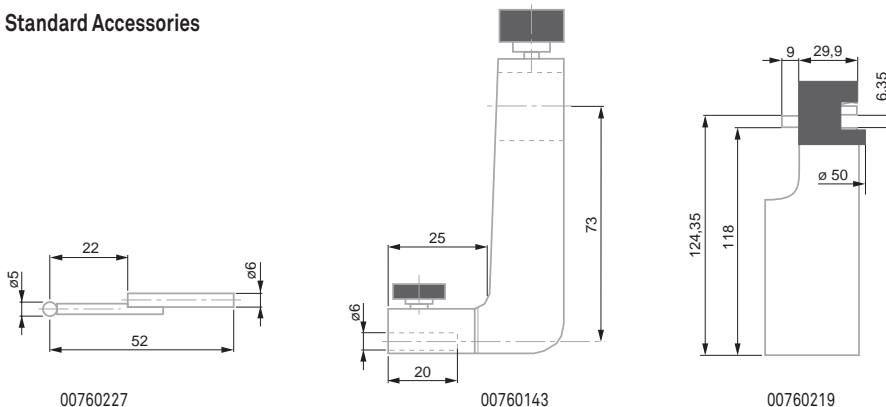

TESA MICRO-HITE 350 / 600 / 900

Autonomous instruments for measurement in one or two coordinate directions of inside dimensions, outside, step, height, depth and distance on geometric elements with flat, parallel or cylindrical surfaces.

The culmination point is automatically entered on the bores and shafts - With memory function "max.", "min." and "max.-min." as dynamic measurement. The use of digital probe TESA IG-13 can also capture perpendicularity, rectitude and parallelism differences, as well as errors of radial and axial runout. Operating results in accordance with ISO 1101.



TESA IG-13

- State-of-the-art concept associated with a high-quality design is the fruit of years of experience in the manufacture of electronic height gauges.
- Ideal for dimensional inspection close to the manufacturing cell. No cumbersome cables to clutter up the working area.
- Fast, simple and reliable probing of the workpiece or holes, especially.
- 3 main gauges available with either a 365, 615 or 920 mm measuring span.
- Numerical display to 0,0005, 0,001, 0,01 and 0,1 mm, or equivalent inch units.
- Extremely accurate measuring of deviations from length, straightness and perpendicularity due to the automatic correction of the bias errors through CAA (Computer Aided Accuracy).
- Coefficient of linear expansion identical to steel ($11,5 \times 10^{-6} K^{-1}$).
- POWER PANEL for value processing and output with interactive display to guide the operator.
- No manual calculation.
- 99 workpiece oriented measurement cycles, programmable. Each cycle includes a number of 64 features with related limits of size.
- Built-in printer for result output or possible use of an external printer unit to get a hard copy in A4 format.
- RS232 data output.
- Every height gauge comes with a SCS calibration certificate.

TESA MICRO-HITE – Power and performance



- Factory standard
- Incremental glass scale with reference point, dividing period of 20 μ m. Opto-electronic value capture (TESA patent).
- Frontal, model 350 < 7 μ m, model 600 < 9 μ m, model 900 < 11 μ m
- Rugged nickel plated base with bottom face including 3 resting points finely lapped
- 1,6 \pm 0,25 N (at switch point for value capture)
- 300 mm/s 12 in/s
- Air cushion usable for easy move of the height gauge over the surface plate.
- Measuring span, application range and accuracy as stated in technical data table
- RS232, opto-electronic
- Rechargeable batteries, 6 V, 3,0 Ah or mains adapter
- \approx 12 hours for one battery pack; \approx 2 hours for the pump used to form the air cushion
- $11,5 \times 10^{-6} K^{-1}$
- 10°C to 40°C
- 10°C to 60°C
- 80 % non-condensing
- IP40 (IEC 60529)
- EN 61326-1, Class B (with disconnected charger)
- Net weight (w/o panel nor battery pack) Main gauges 350: 33 kg 600: 38 kg 900: 45 kg
- Shipping packaging
- Identification number
- SCS calibration certificate



| No | = | | | |
|------------------------------|---|------------|------------|------------|
| | | mm | in | |
| 00730033 | SET MICRO-HITE 350 | 365 | 14 | |
| 00730034 | SET MICRO-HITE 600 | 615 | 24 | |
| 00730035 | SET MICRO-HITE 900 | 920 | 36 | |
| CONSISTING OF: | | 350 | 600 | 900 |
| 00730021 | TESA MICRO-HITE 350 main gauge | ● | | |
| 00730022 | TESA MICRO-HITE 600 main gauge | | ● | |
| 00730023 | TESA MICRO-HITE 900 main gauge | | | ● |
| 00760141 | Rechargeable battery pack | ● | ● | ● |
| 00760142 | Electric pump for creating the air-cushion beneath the gauge base, already mounted | ● | ● | ● |
| 00760143 | Standard probe insert holder | ● | ● | ● |
| 00760150 | Master piece for establishing the probe constant, nominal dimension to 20,000 mm / 0.78740 in | ● | ● | ● |
| 00760151 | Dust cover for TESA MICRO-HITE 350 | ● | | |
| 00760152 | Dust cover for TESA MICRO-HITE 600 | | ● | |
| 00760153 | Dust cover for TESA MICRO-HITE 900 | | | ● |
| 00760227 | Standard probe insert with shank and 5 mm dia. ball tip in tungsten carbide | ● | ● | ● |
| 04761054 | Mains adapter 100 ÷ 200 VAC / 50 ÷ 60 Hz | ● | ● | ● |
| 04761055 | Cable EU for mains adapter | ● | ● | ● |
| OPTIONAL ACCESSORIES: | | | | |
| 00760144 | Add-on fine adjust device for extra fine movement of the measuring head, complete | | | |
| 00760157 | Rechargeable battery, 6V | | | |
| 04761023 | Cable: miniDIN 8p/m to Sub-D 9p/f, 2m for TT10 and MICRO-HITE manual versions 10/11/12 | | | |
| 04761056 | Cable US for mains adapter | | | |

Technical Data

| | Models | | | | |
|--|---|----------------|---|----------------|----------|
| | | MICRO-HITE 350 | MICRO-HITE 600 | MICRO-HITE 900 | |
| | | mm | 365 | 615 | 920 |
| | | in | 14 | 24 | 36 |
| | With standard accessory | mm | 0 ÷ 520 | 0 ÷ 770 | 0 ÷ 1075 |
| | | in | 0 ÷ 20 | 0 ÷ 30 | 0 ÷ 42 |
| | With probe holder No. 00760057 | mm | 0 ÷ 575 | 0 ÷ 825 | 0 ÷ 1130 |
| | | in | 0 ÷ 22 | 0 ÷ 32 | 0 ÷ 44 |
| | With probe holder No. S07001622 | mm | 0 ÷ 745 | 0 ÷ 995 | 0 ÷ 1300 |
| | | in | 0 ÷ 29 | 0 ÷ 39 | 0 ÷ 51 |
| | With standard accessory | | (2 + 3 L) μm (L in m) (0.0001 + 0.000003 L) in (L in in) | | |
| | With standard accessory | | 2σ ≤ 1 μm / ≤ 0.00005 in | | |
| | Frontal, mechanical | μm | 7 | 9 | 11 |
| | | in | 0.00028 | 0.00035 | 0.00043 |
| | Frontal and lateral with TESA IG-13 probe | μm | 6 | 8 | 10 |
| | | in | 0.00024 | 0.00031 | 0.00039 |

Standard Accessories

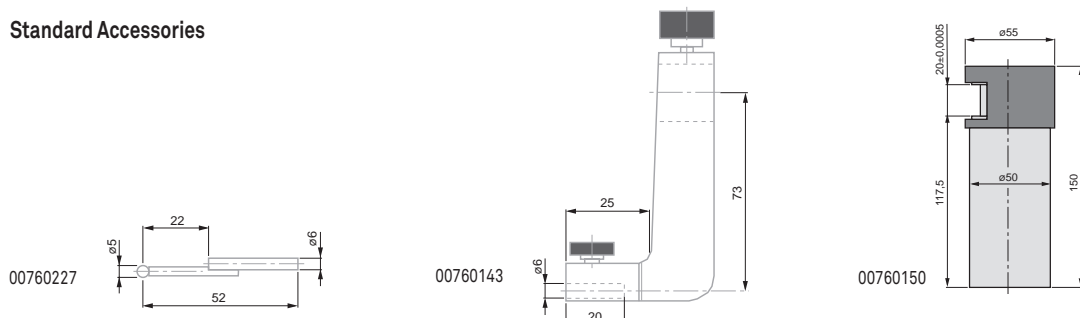

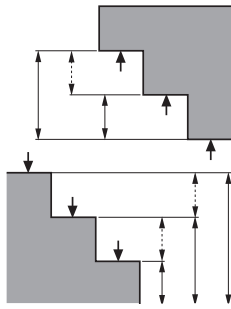

One-dimensional measurement

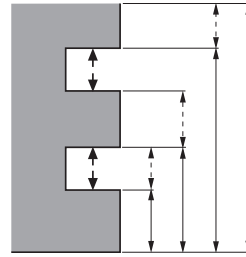

One-dimensional measurement

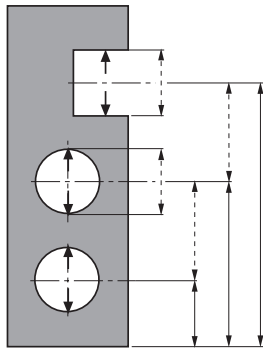

One-dimensional measurement

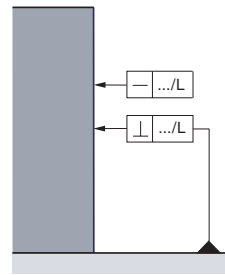

Programme functions for the detection of form and position errors.
With use of a TESA IG-13 digital probe.

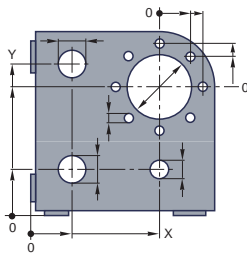

Two-Dimensional Measurement

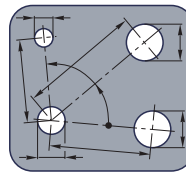

Two-Dimensional Measurement

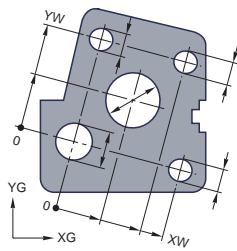

Two-Dimensional Measurement

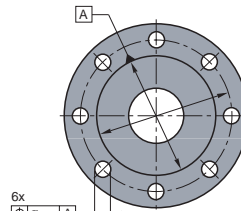

Two-Dimensional Measurement



Control Panel for TESA MICRO-HITE 350 / 600 / 900



See below

Main Display 12,7 x 6,4 mm, 6,3 x secondary display 4,2 mm.

Floating zero

Conversion mm/in

Through TESA MICRO-HITE

IP40 (CEI 60529)



Dual LCD display size 128 x 63 mm.

- Measurement of lengths value display (7 segments / sign) and function symbols (top).
- Measurement of squareness / rectitude display values and symbols (function keys, control by the operator display (points))
- Measured: 7 decades Reduce sign.

PRESET function for entering a given value. Continuous displaying. Manual or automatic triggering of data transfer. Output of pre-defined report with headers in 5 languages plus A4 format using an external printer unit.

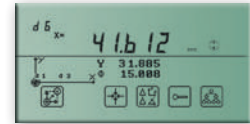
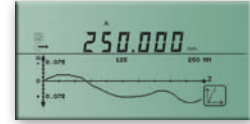

| No | = | mm | in |
|----------------------------|---------------------------|-----------------------------|---------------------------------------|
| 00760163 | Power Panel | 0,0005 / 0,001 / 0,01 / 0,1 | 0,00002 / 0,0001 / 0,001 / 0,01 / 0,1 |
| OPTIONAL ACCESSORY: | | | |
| 04765008 | Thermal paper, 57 mm wide | | |





TESA MICRO-HITE Plus M 350 / 600 / 900

All TESA MICRO-HITE plus M height gauges are unique in that they have exceptional metrological capabilities and can be used intuitively with ease.

This method allows form and position error to be easily and quickly detected by means of a lever-type dial indicator – Check deviations from straightness or parallelism according to ISO 1101 when used in conjunction with TESA IG-13 linked to the Power panel plus M.

- Modular design descending from the successful TESA MICRO-HITE dynasty.
- Also equipped with the unique rotary power control located close to the rugged base. This feature serves for guiding the column that moves on an air cushion, commanding fast motion of the probe insert and triggering all main measuring functions. Its intuitive use allows accurate, easy handling of the column. A simple rotation causes the measuring head to move rapidly, approach the contact point quickly or slowly, probe up- or downward or execute bore measurement.
- Available in three different sizes with a measuring span of 365, 615 or 920 mm.
- Choice between two control panels for value processing and output.
- Metric and inch LC display with a resolution to 0,0001 and 0,001 mm, or inch equivalent.
- Autonomous run through batteries. No cumbersome cable.
- Built-in air bearing for easy displacement over the surface plate.
- Motorised measuring head for fast, accurate probing at each contact point with a constant measuring force.
- TESA μ system for matchless reliability and simplicity.
- High precision through CAA (Computer Aided Accuracy). All correction values stored in the memory still add to the mechanical precision.
- Coefficient of linear expansion matching that of steel ($11,5 \times 10^{-6} \text{ K}^{-1}$).
- RS232 data output.
- SCS calibration certificate delivered with every height gauge.



Factory standard

Incremental glass scale with opto-electronic data acquisition. Grating period: 20 μm . Opto-electronic input (TESA Patent)

Frontal, for model 350 < 5 μm , 600 < 7 μm , 900 < 9 μm .

Rugged nickel plated gauge base having 3 resting points, finely lapped

1 N Coupled for triggering the measuring force

Built-in air-bearing for easy move of the column over the surface plate

Measuring head mounted on a ball-bearing. Motorised head displacement at a varying speed from 7,5 up to 40 mm/s. Manual displacement: $\leq 600 \text{ mm/s}$. Automatic value capture with a constant measuring force.

Field measurement application range and accuracy: see technical data table

Rechargeable 6 V, 3.0 Ah or network adapter 100 ÷ 240 Vac/50 ÷ 60 Hz

$\approx 12 \text{ h}$ after 8 h of charging



TESA μ System



Perpendicularity using TESA IG-13



Perpendicularity using TESATAST

TESA MICRO-HITE plus M

Unrivalled Power, Performances, Ease of use



- 11,5 x 10⁻⁶ K⁻¹
- 10 °C to 40 °C
- 10 °C to 60 °C
- 80 %, no condensation
- IP40 (CEI 60529)
- EN 61326-1, Class B (offline charging)
- Net weight without desks or block batteries. Basic instrument 350: 33 kg, 600: 38 kg, 900: 45 kg
- Shipping packaging
- ID Number
- Declaration of conformity
- Calibration certificate SCS

| No | = | | | |
|----------------------------|--|------------|------------|------------|
| | | | | |
| 00730063 | Set MICRO-HITE plus M 350 | 365 | 14 | |
| 00730064 | Set MICRO-HITE plus M 600 | 615 | 24 | |
| 00730065 | Set MICRO-HITE plus M 900 | 920 | 36 | |
| CONSISTING OF: | | 350 | 600 | 900 |
| 00730060 | TESA MICRO-HITE plus M 350 main gauge | ● | | |
| 00730061 | TESA MICRO-HITE plus M 600 main gauge | | ● | |
| 00730062 | TESA MICRO-HITE plus M 900 main gauge | | | ● |
| 00760141 | Rechargeable battery pack | ● | ● | ● |
| 00760142 | Electric pump for creating the air-cushion beneath the gauge base, already mounted | ● | ● | ● |
| 00760143 | Standard probe insert holder | ● | ● | ● |
| 00760219 | Master piece for establishing the probe constant, nominal dimension to 6,350 mm / 0.250 in | ● | ● | ● |
| 00760151 | Dust cover for TESA MICRO-HITE 350 | ● | | |
| 00760152 | Dust cover for TESA MICRO-HITE 600 | | ● | |
| 00760153 | Dust cover for TESA MICRO-HITE 900 | | | ● |
| 00760227 | Standard probe insert with shank and 5 mm dia. ball tip in tungsten carbide | ● | ● | ● |
| 04761054 | Mains adapter 100 ÷ 200 VAC / 50 ÷ 60 Hz | ● | ● | ● |
| 04761055 | Cable EU for mains adapter | ● | ● | ● |
| 04761056 | Cable US for mains adapter | ● | ● | ● |
| OPTIONAL ACCESSORY: | | | | |
| 00760157 | Rechargeable battery, 6V | | | |

Technical data

| | Models | | MICRO-HITE plus M 350 | MICRO-HITE plus M 600 | MICRO-HITE plus M 900 |
|--|--|----|---|-----------------------|-----------------------|
| | | mm | 365 | 615 | 920 |
| | | in | 14 | 24 | 36 |
| | With standard accessory | mm | 0 ÷ 520 | 0 ÷ 770 | 0 ÷ 1075 |
| | | in | 0 ÷ 20 | 0 ÷ 30 | 0 ÷ 42 |
| | With probe insert holder No. 00760057 | mm | 0 ÷ 575 | 0 ÷ 825 | 0 ÷ 1130 |
| | | in | 0 ÷ 22 | 0 ÷ 32 | 0 ÷ 44 |
| | With probe insert holder No. S07001622 | mm | 0 ÷ 745 | 0 ÷ 995 | 0 ÷ 1300 |
| | | in | 0 ÷ 29 | 0 ÷ 39 | 0 ÷ 51 |
| | With standard accessory | | (1,9 + 1,5 L) µm (L in m) (0.0001 + 0.0000015 L) in (L in in) | | |
| | With standard accessory | | On flat surfaces: 2σ ≤ 0,5 µm / ≤ 0.000025 in Into bores: 2σ ≤ 1 µm / ≤ 0.00005 in | | |
| | Frontal, mechanical | µm | 5 | 7 | 9 |
| | Frontal and lateral using TESA IG-13 | in | 0,00020 | 0,00028 | 0,00035 |

Standard Accessories

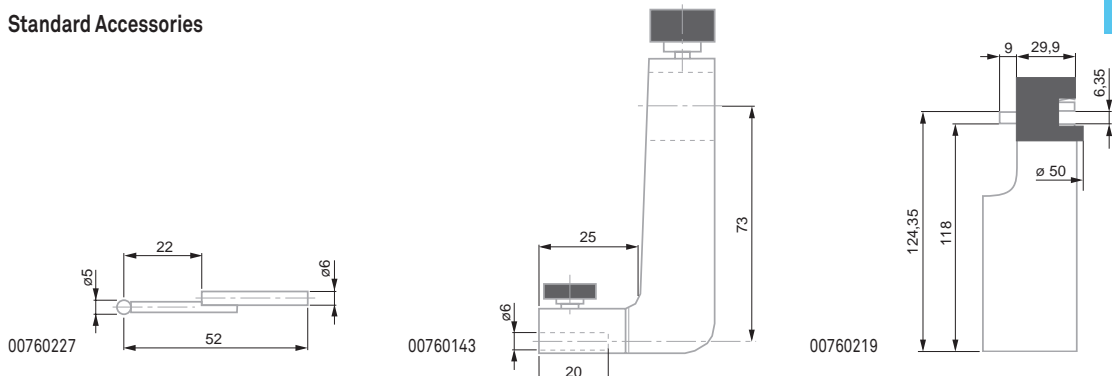

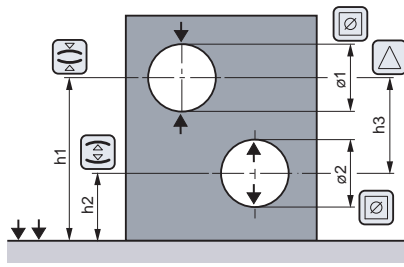

Measurement with change of the probe direction
Probe constant included, considering the culmination point

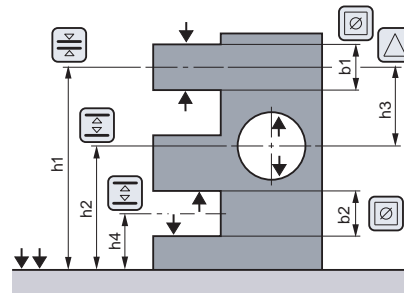

Measurement with change of the probe direction
Probe constant included, disregarding the culmination point

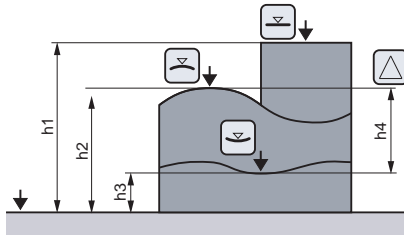

Measurement without change of the probe direction
Probe constant excluded

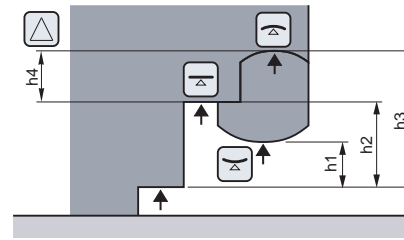

Measurement without change of the probe direction
Probe constant excluded

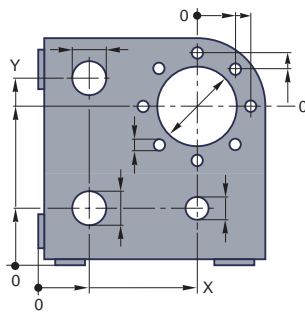

Two-Dimensional Measurement

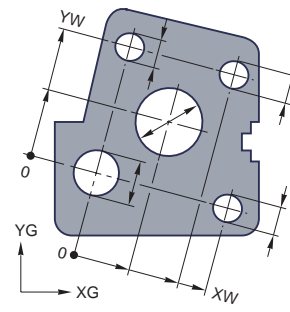

Two-Dimensional Measurement

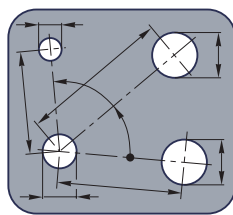

Two-Dimensional Measurement

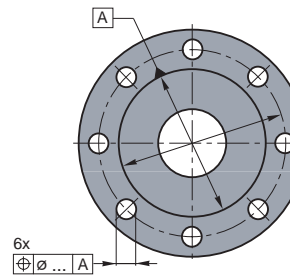

Two-Dimensional Measurement

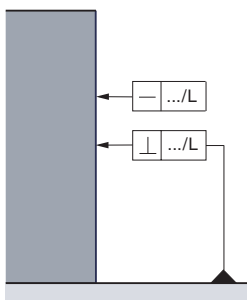

Measurement of form and position errors

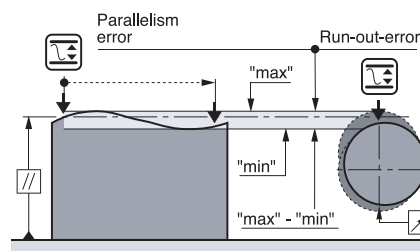

Measurement of form and position errors



Control Panels for TESA MICRO-HITE Plus M 350 / 600 / 900



See opposite

12,7 x 6,4 mm main display, 6,3 x 4,2 or 3,8 x 2,9 mm auxiliary display

mm/in conversion

Via TESA MICRO-HITE plus M

IP50 (IEC 60529)



Declaration of conformity

Keypad with 42 softkeys

Bidirectional RS232, optoelectronic and Centronics

LC dual display, 128 x 63 mm in size.

- Length measurement: 7-segment/digit upper display field for values plus symbols for the functions.

- Straightness or perpendicularity measurement: display field for values plus symbols (function keys). Operator controlled operations (full dot display).

- Measured values: 7-decade display plus minus sign.

- PRESET function for entering a given value. Acoustic signal. Manual or automatic triggering of data transfer. Output of predefined reports with headers in 5 languages (plus a programmable one) using an external printer unit (A4 format).

No



mm

in

| | | | |
|----------|--|-----------------------|--------------------------|
| 00760220 | Power Panel for MICRO-HITE plus M with printer | 0,0001 / 0,001 / 0,01 | 0.00001 / 0.0001 / 0.001 |
| 00760221 | Power Panel for MICRO-HITE plus M | 0,0001 / 0,001 / 0,01 | 0.00001 / 0.0001 / 0.001 |

OPTIONAL ACCESSORIES:

| | |
|----------|--|
| 04765008 | Thermal paper, 57 mm wide |
| 04761052 | Extension cable, Sub-D 9p/f to 9p/m, 2 m |
| 04761063 | Sub-D 9p/m to USB cable, 2 m |



TESA IG-13 Probe Set for Perpendicularity Measurement



Factory standard



Shipping packaging

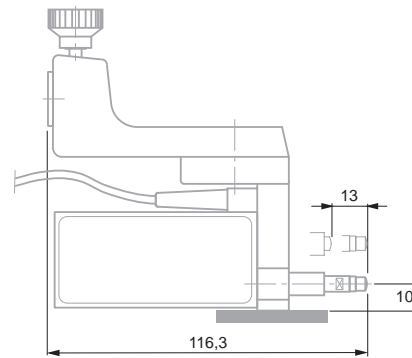

00760140

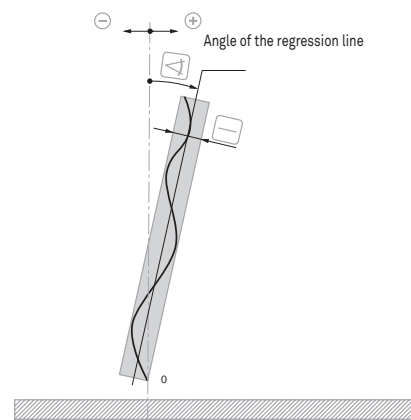
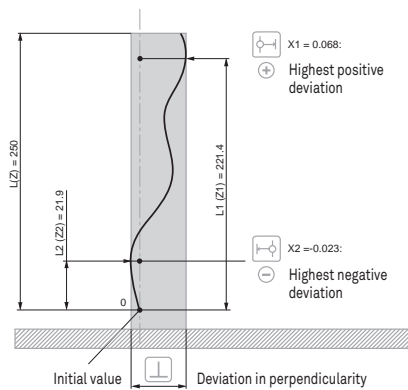

00760140 TESA IG-13 Probe set

CONSISTING OF:

00760138 TESA IG-13 Attachment

00760139 TESA IG-13 Digital probe

OPTIONAL ACCESSORIES:

01960005 Retraction lever

04761047 Connecting cable IG-13/Power Panel plus M 1 m (mini-DIN)



- Factory standard
- 100 mm / 4 in
- 0 to 160 mm 0 to 6.3 in
- 0,001 mm and 0,0001 mm or 0.0001 in and 0.00001 in
- Incremental glass scale with opto-electronic data acquisition. Grating period: 20 µm.
- Error max. tolerated G: see table
- Repeatability limit: see table
- Accuracy class according to DIN 876, Part 1
- finely lapped
- Measuring table (L x P x H) 200 x 300 x 50 mm, Ø column 50 x 300 mm.
- Granite measuring table; dull-chrome plated steel column, hardened and ground.
- 0,63 ± 0,1 N and 1 ± 0,1 N, switchable. Electromotorised activation.
- Numerical interval to 0,001 mm/ 0,0001 in = 10 mm/s; to 0,0001 mm/ 0,00001 in = 5 mm/s; fast displacement = 30 mm/s
- Electro-motorised gauge head displacement; can also be moved manually.
- Via the control panel
- 11,5 x 10⁻⁶ K⁻¹

TESA-µHITE

Compact design with measuring stand included – Sensor equipped with a system for coaxial measuring according to the Abbe principle or using an offset probe relative to the gauge axis. Measures internal, external, height, depth, step and distance dimensions on geometric elements having either a flat, parallel or cylindrical surface – Automatic detection of the culminating point on bores or shafts – Dynamic probing with memory functions "max.", "min." and "max.-min.". The whole system provides the best solution for measuring straightness, flatness and parallelism or inspecting axial and radial runouts depending on the chosen tool configuration.

- Ideal for workpiece inspection close to the production area.
- 100 mm measuring span.
- 0,001 mm and 0,0001 mm or 0.0001 in and 0.00001 in scales intervals.
- Max. perm. error as low as 2 µm (or 1 µm when checking coaxiality).
- Integrated temperature sensor so that the coefficient of linear expansion of each gauge unit matches that of steel (11,5 x 10⁻⁶ K⁻¹).
- Motorised measuring head for fast probing at each point.
- Automatic value capture, controlled over the stability of the measuring force, but also all measured values.
- Constant measuring force through the motor-driven actuator. Switchable.
- No manual calculation needed.
- RS232 data output with direct connection to TESA PRINTER SPC.
- Memory capacity for 99 single values.

Accuracy

| Insert's position relative to the axis of the measuring bolt | | | | |
|--|-----|---------|-----|---------|
| | µm | in | µm | in |
| Coaxial | 1,0 | 0.00005 | 0,5 | 0.00002 |
| Offset | 2,0 | 0.0001 | 1,0 | 0.00004 |

Applicable with used standard accessory

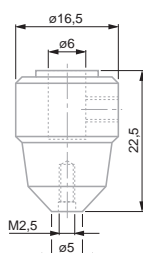
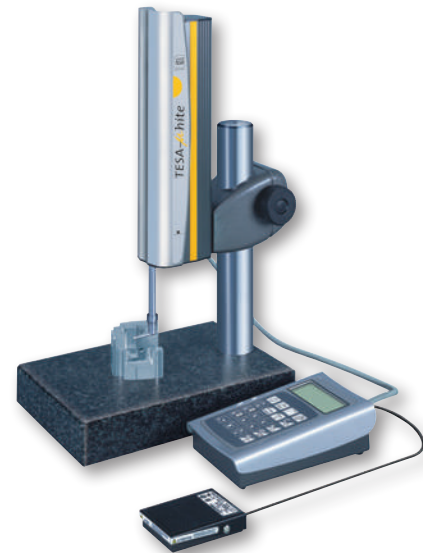

00760195

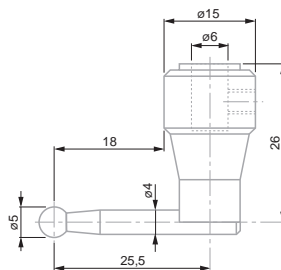

00760197

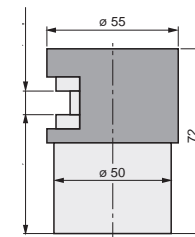

00760192

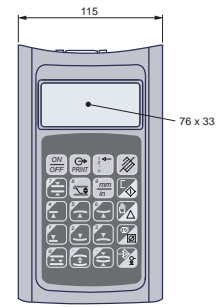

00760204

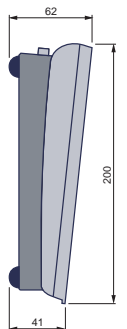

| No | TESA-μHITE | mm 0 ÷ 160 | in 0 ÷ 6,3 | μm Coaxial tip: 1,0 off-centre tip 2,0 | μm / in Coaxial tip: 0,5 / 0.00002; off-centre tip 1,0 / 0,00004 |
|----|------------|---------------|---------------|--|---|
|----|------------|---------------|---------------|--|---|

CONSISTING OF:

- 00760203 TESA measuring support, granite measuring table, size 200 x 300 x 50 mm
- 00730054 TESA-μHITE electronic measuring equipment

CONSISTING OF:

- 038407 1 plastic case
- 00730050 TESA-μHITE probe
- 00760191 Connecting cable Panel / TESA-μHITE
- 00760192 Master piece for establishing the probe constant, nominal dimension 10 mm / 0.39370 in
- 00760195 Axial insert holder M2,5
- 00760197 Probe insert with a 5 mm dia. tungsten carbide ball tip, offset
- 00760204 Control panel, to be connected to TESA-μHITE
- 03510002 Measuring insert TN10W
- 04761054 Mains adapter 100 ÷ 200 VAC / 50 ÷ 60 Hz
- 04761055 Cable EU for mains adapter
- 04761056 Cable US for mains adapter

OPTIONAL ACCESSORIES:

- 00760186 Set of probe inserts for TESA-μHITE
- 04761052 Extension cable, Sub-D 9p/f to 9p/m, 2 m
- 04761063 Sub-D 9p/m to USB cable, 2 m

- 5°C to 40°C
- 10°C to 60°C
- 80 %, non-condensing
- IP50 (IEC 60529)
- EN 61326-1, Class B
- Net weight 16,2 kg (measuring support No. 00760203), net weight 2,6 kg (TESA-μHITE No. 00730050), net weight 1,45 kg (control panel No. 00760204 with cable No. 00760191)
- Shipping packaging
- Identification number
- Declaration of conformity
- SCS calibration certificate

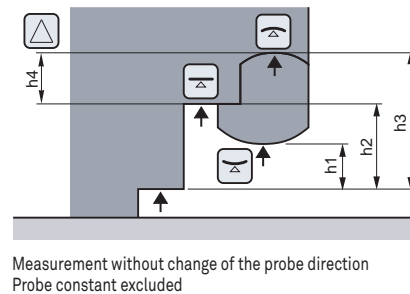
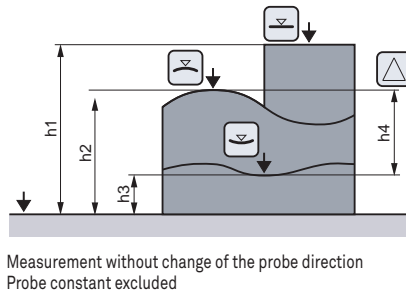

Measurement with change of the probe direction
Probe constant included, considering the culmination point

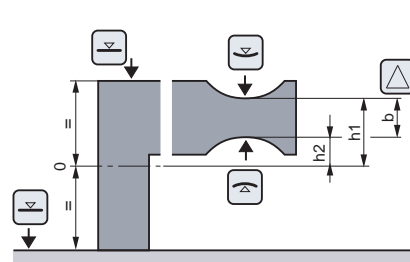
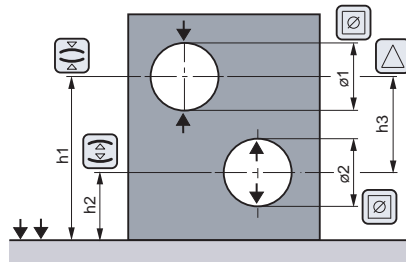

Measurement with change of the probe direction
Probe constant included, disregarding the culmination point

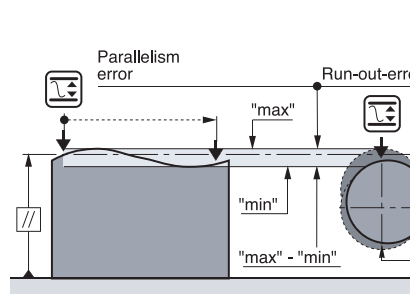
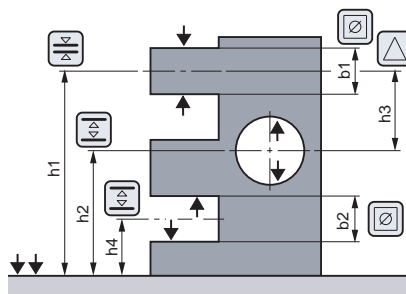



Shipping packaging

Declaration of conformity

Optional Accessories for TESA- μ Hite

| No | = |
|----------|---|
| 00760194 | Axial probe holder for probe inserts with a M1,4 thread |
| 00760196 | Axial probe holder for probe inserts with a M3 thread |
| 00760198 | Radial probe holder with a 4 mm dia. mounting bore |
| 00760199 | Universal probe insert holder with a 4 mm dia. clamping shank (used in conjunction with radial probe holder No. 00760198). M1,4 plus M3 threads (2 x 2) for the probe inserts |
| 00760200 | Probe insert with a 5 mm dia. tungsten carbide ball tip. Also with a 4 mm dia. fixing rod for use with radial probe holder insert No. 00760198. |
| 00760201 | Probe insert with a 3 mm dia. tungsten carbide ball tip. Also with a 4 mm dia. fixing rod for use with radial probe holder No. 00760198. |
| 00760202 | Spare batteries for control panel No. 00760204, 6 Vdc/1,2 Ah. |
| 00760207 | Swivel support for control panel |

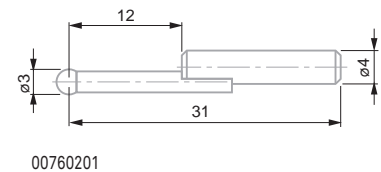
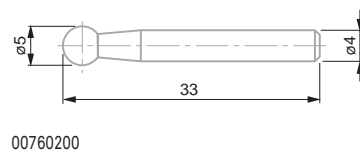
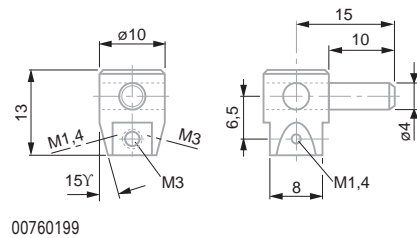
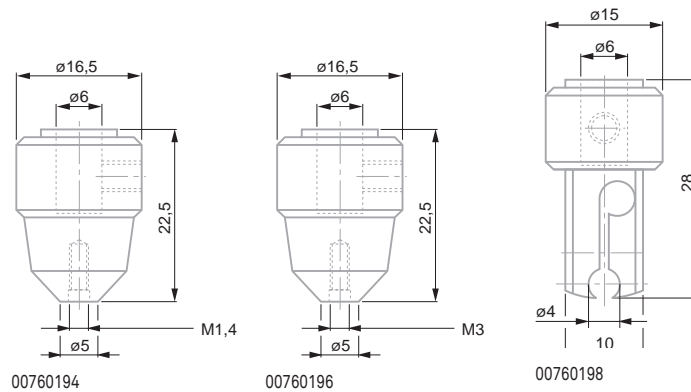

Sets of Accessories for Height Gauges



Shipping packaging



Declaration of conformity



00760232 Starter accessory kit with 4 elements for TESA Height Gauges

CONSISTING OF:

00760061 Probe insert with a 3 mm dia. carbide ball tip

00760075 Probe insert with a carbide disc tip $E = 2 \text{ mm} / \varnothing 14 \text{ mm}$ for grooves, slots, centering shoulders etc.

00760082 2 mm dia. probe insert with a small cyl. carbide face

00760094 Probe inserts with a stainless steel shank, hardened. Also with one flat and one spherical carbide measuring face. Interchangeable shank.

059215 Plastic box

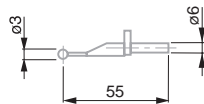

00760061

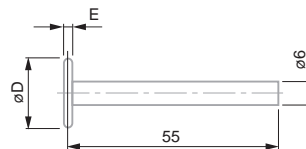

00760075

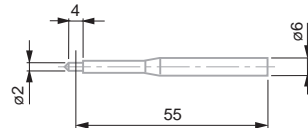

00760082

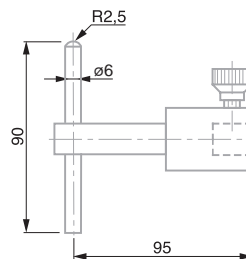

00760094





Shipping packaging

Declaration of conformity

Sets of Accessories for Height Gauges

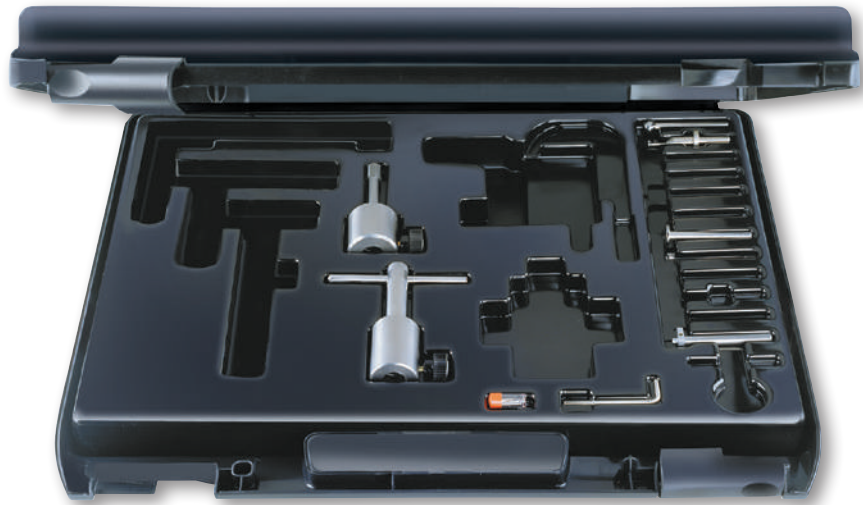

00760173 Starter accessory kit with 8 elements for TESA Height Gauges

CONSISTING OF:

- 00760061** Probe insert with a 3 mm dia. carbide ball tip
- 00760060** Probe insert with a 10 mm dia. carbide ball tip
- 00760075** Probe insert with a carbide disc tip E = 2 mm / Ø 14 mm for grooves, slots, centering shoulders etc.
- 00760093** Probe insert with a cylindrical, tungsten carbide measuring face (10 mm dia., 12 mm long). Stainless steel body, hardened.
- 00760094** Probe inserts with a stainless steel shank, hardened. Also with one flat and one spherical carbide measuring face. Interchangeable shank.
- 00760228** Probe insert dia. 1 mm with shank and ball tip in tungsten carbide
- 00760229** Probe insert dia. 2 mm with shank and ball tip in tungsten carbide
- 00760230** Probe insert dia. 3 mm with shank and ball tip in tungsten carbide

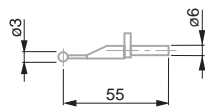

00760061

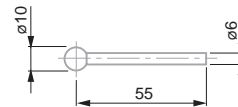

00760060

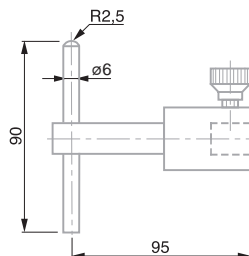

00760094

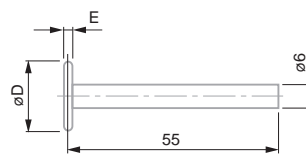

00760075

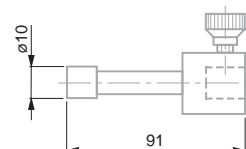

00760093

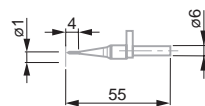

00760228

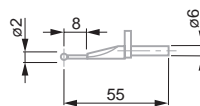

00760229

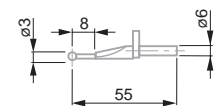

00760230



Sets of Accessories for Height Gauges



Shipping packaging



Declaration of conformity

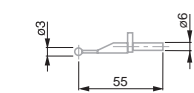

00760061

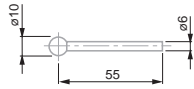

00760060

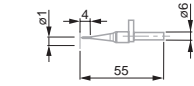

00760228

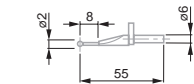

00760229

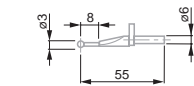

00760230

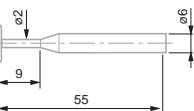

00760074

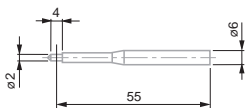

00760082

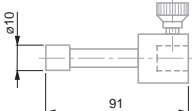

00760093

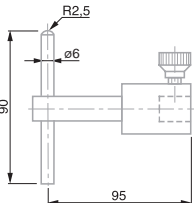

00760094



00760148 Full accessory set with 17 elements for TESA Height Gauges

CONSISTING OF:

- 00760057** Probe insert holder for extending the application range
- 00760060** Probe insert with a 10 mm dia. carbide ball tip
- 00760061** Probe insert with a 3 mm dia. carbide ball tip
- 00760066** Probe insert \varnothing 2,2 mm (for M3 to M16 threads) with carbide, barrel-shaped measuring faces for cylindrical bores as well as for determining the position of metric inside threads (or similar).
- 00760067** Probe insert \varnothing 4,5 mm (for M6 to M48 threads) with carbide, barrel-shaped measuring faces for cylindrical bores as well as for determining the position of metric inside threads (or similar).
- 00760068** Probe insert \varnothing 9,7 mm (for M12 to M150 threads) with carbide, barrel-shaped measuring faces for cylindrical bores as well as for determining the position of metric inside threads (or similar).
- 00760074** Probe insert with a carbide disc tip $E = 1$ mm / \varnothing 4,5 mm for grooves, slots, centering shoulders etc.
- 00760075** Probe insert with a carbide disc tip $E = 2$ mm / \varnothing 14 mm for grooves, slots, centering shoulders etc.
- 00760076** Probe insert with a carbide disc tip $E = 3$ mm / \varnothing 19 mm for grooves, slots, centering shoulders etc.
- 00760082** 2 mm dia. probe insert with a small cyl. carbide face
- 00760086** Probe insert holder for depth up to 110 mm ($L = 75$ mm)
- 00760087** Probe insert holder for depth up to 185 mm ($L = 150$ mm)
- 00760094** Probe inserts with a stainless steel shank, hardened. Also with one flat and one spherical carbide measuring face. Interchangeable shank.
- 00760228** Probe insert dia. 1 mm with shank and ball tip in tungsten carbide
- 00760229** Probe insert dia. 2 mm with shank and ball tip in tungsten carbide
- 00760230** Probe insert dia. 3 mm with shank and ball tip in tungsten carbide

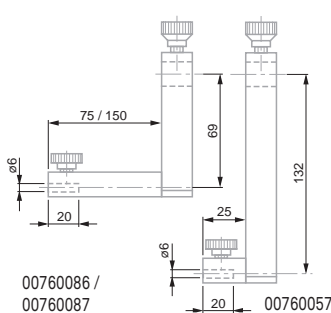

00760086 /
00760087

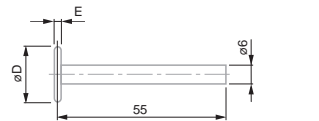

00760076

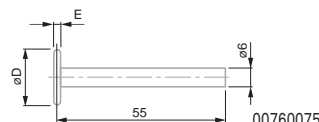

00760075

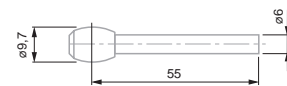

00760068

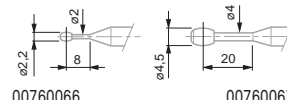

00760066

00760067





Shipping packaging

Declaration of conformity

Sets of Accessories for Height Gauges



00760175 Set of probe inserts for TESA-HITE, TESA-HITE plus M, TESA-HITE magna, MICRO -HITE and MICRO-HITE plus M

CONSISTING OF:

00760177 Probe insert holder

00760178 Hardened steel rod for grooves, centring shoulders, blind bores etc, angled through 8°

00760179 Tungsten carbide cylindrical rod for depth measurement

00760180 Probe inserts with a 0,9 mm dia. hardened steel ball tip

00760181 Probe inserts with a 1,9 mm dia. hardened steel ball tip

00760182 Probe inserts with a 1,9 mm dia. hardened steel ball tip

00760183 Hardened steel probe insert with a cone-shaped measuring face, 8 mm dia.

00760184 Extension, 20 mm, with a M3 thread for inserts with M3 thread

00760185 Extension, 20 mm, with a M3 thread for inserts with M2,5 thread

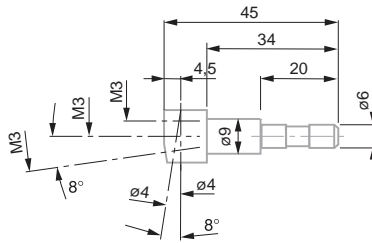

00760177

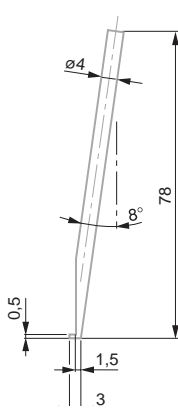

00760178

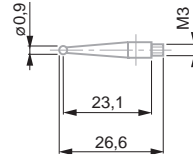

00760180

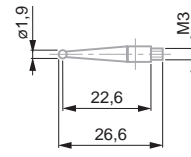

00760181

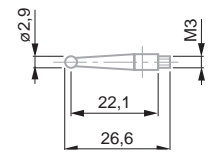

00760182

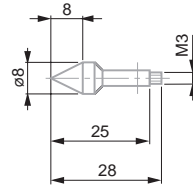

00760183

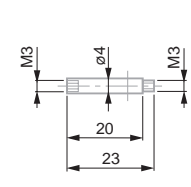

00760184

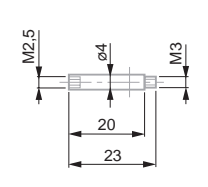

00760185

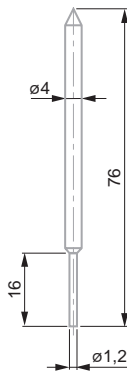

00760179

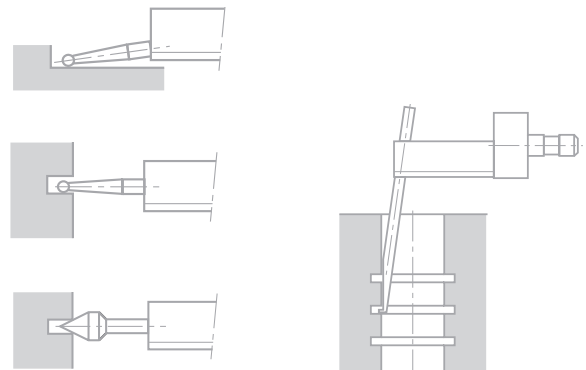

Sets of Accessories for Height Gauges



Shipping packaging



Declaration of conformity



| | |
|-----------------------|--|
| 00760186 | Set of probe inserts for TESA- μ HITE |
| CONSISTING OF: | |
| 00760178 | Hardened steel rod for grooves, centring shoulders, blind bores etc, angled through 8° |
| 00760179 | Tungsten carbide cylindrical rod for depth measurement |
| 00760180 | Probe inserts with a 0,9 mm dia. hardened steel ball tip |
| 00760181 | Probe inserts with a 1,9 mm dia. hardened steel ball tip |
| 00760182 | Probe inserts with a 2,9 mm dia. hardened steel ball tip |
| 00760183 | Hardened steel probe insert with a cone-shaped measuring face, 8 mm dia. |
| 00760184 | Extension, 20 mm, with a M3 thread for inserts with M3 thread |
| 00760185 | Extension, 20 mm, with a M3 thread for inserts with M2,5 thread |
| 00760187 | Probe insert holder |

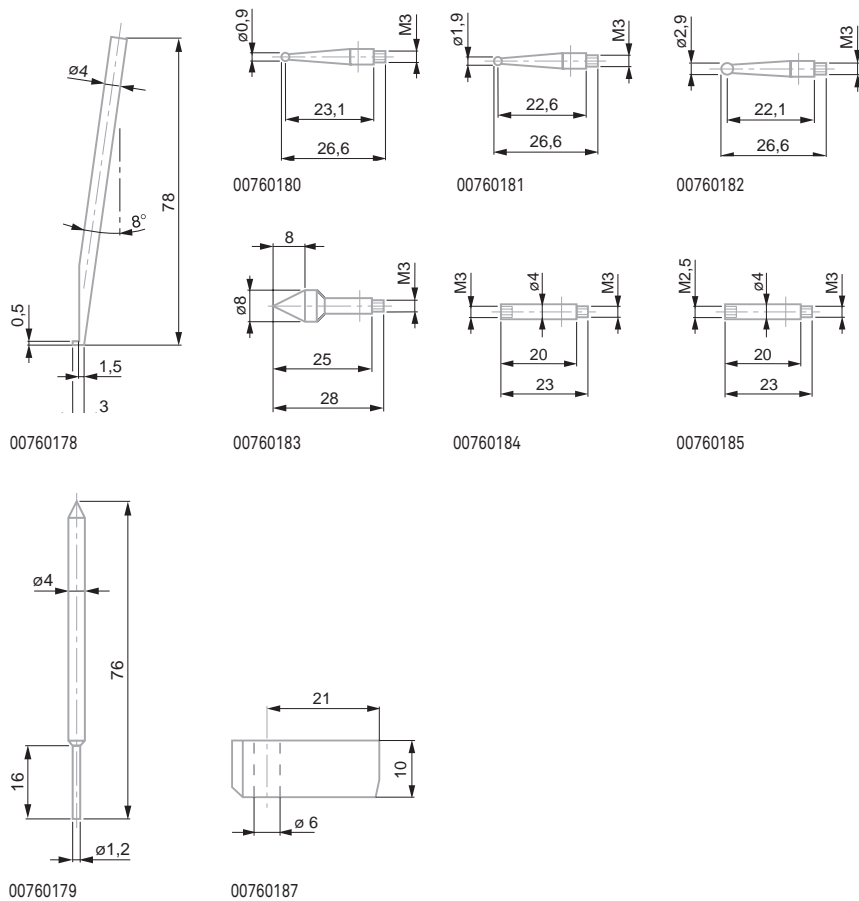

- Factory standard
- Shipping packaging

Probe Holder No. 00760223 for Inserts with 8 mm Diameter



00760223 Probe holder for inserts with 8 mm diameter

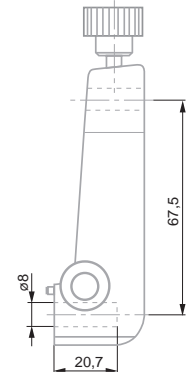

- Factory standard
- Shipping packaging

Optional Accessories for Use with Insert Holder No. 00760223



- 0071684815 Probe insert with a 4 mm dia. tungsten carbide ball tip
- 0071684816 Probe insert with a 6 mm dia. tungsten carbide ball tip
- 0071684817 Long probe insert with a 10 mm dia. tungsten carbide ball tip
- 0071684818 Probe insert with a 1 mm dia. steel tip, hardened. Also with adjustable shank for depth measurement.
- 0071684819 Probe insert with cone-shaped measuring face in hardened steel for $\varnothing 5 \div 20$ mm
- 0071684820 Probe insert with cylindrical measuring face in hardened steel, $\varnothing 10$ mm, 12 mm long
- 0071684822 Probe insert with cone-shaped measuring face in hardened steel, $\varnothing 0,5 \div 5,5$ mm
- 0071684825 Probe insert with a 6 mm dia. tungsten carbide ball tip
- 0071684826 Attachment for interchangeable inserts with M1,4 thread. Supplied with 1 insert No. 01860201 having a 1 mm dia. carbide ball tip.
- 0071684827 Probe insert with disc-shaped face $\varnothing 12$ mm, 3 mm wide
- 0071684828 Attachment for interchangeable insert with M1,4 thread. Supplied with 2 probe inserts No. 0186020 having a 2 mm dia. carbide ball tip
- 0071684829 Probe insert with a 10 mm dia. tungsten carbide ball tip
- 0071684832 Probe insert with a 8 mm dia. tungsten carbide ball tip

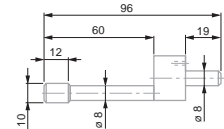

0071684820

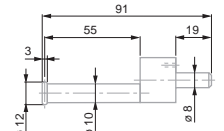

0071684827

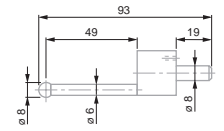

0071684832

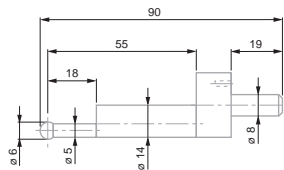

0071684825

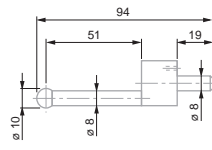

0071684829

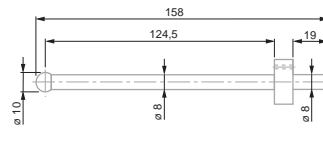

0071684817

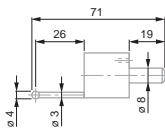

0071684815

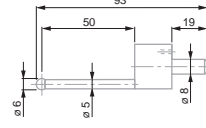

0071684816

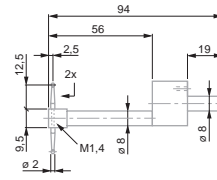

0071684828

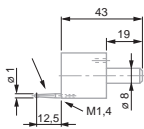

0071684826

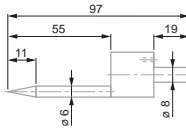

0071684822

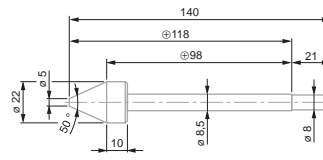

0071684819

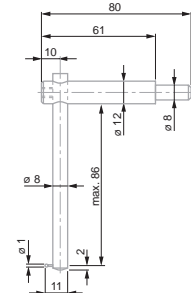

0071684818



Accessories for Measuring Perpendicularity by Means of a Dial Test Indicator

Used with TESA MICRO-HITE plus M, TESA MICRO-HITE, TESA-HITE 400/ 700 and TESA-HITE plus M 400/ 700.

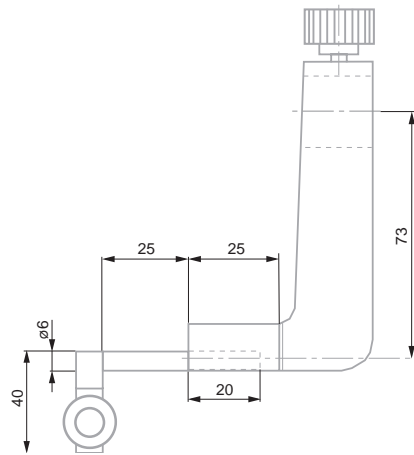

00760222 Probe insert holder for a dial test indicator (lever-type)



- Factory standard
- Floating zero
- DIN 862
For lengths up to
600 mm = 30 µm
1000 mm = 40 µm
- Steel base,
hardened
- Wooden case
- Declaration of
conformity
- Identification
number
- Slider with inter-
changeable scriber.
Also with back
mounted clamping
holder having a
8 mm diameter.
Slider with locking
screw and fine
adjust device.
Base has a ground
face with dust
grooves. Top face
also ground.
- Preset and Hold
functions



ETALON Height and Scribing Gauges with Digital Display

Electronic height and scribing gauges

- Resolution to 0,01 mm/0.005 in
- RS232 interface

| No | mm | in | Column, mm | Base (L x H x W) mm |
|----------|----------|--------|---------------|------------------------|
| 07739001 | 0 ÷ 300 | 0 ÷ 12 | 25 x 6 | 60 x 40 x 100 |
| 07739002 | 0 ÷ 600 | 0 ÷ 24 | 30 x 12 | 110 x 50 x 160 |
| 07739003 | 0 ÷ 1000 | 0 ÷ 40 | 30 x 12 | 110 x 50 x 160 |

Accessories for ETALON Height and Scribing Gauges with Digital Display



07769005



07769006

| No | = | A | Length, mm |
|----------|---|-------------------------------|---------------|
| 07769001 | Scriber for 300 mm length 65 mm | Suitable for models 300 | 65 |
| 07769003 | Scriber for 6 to 1000 mm, length 75 mm | 600, 1000 | 75 |
| 07769005 | Holder to replace the scriber | | |
| 07769006 | Rotating and tilting version with a 8 mm dia. shank. To be used with No. 07769005 | | |





Electronic Length Measuring Equipment

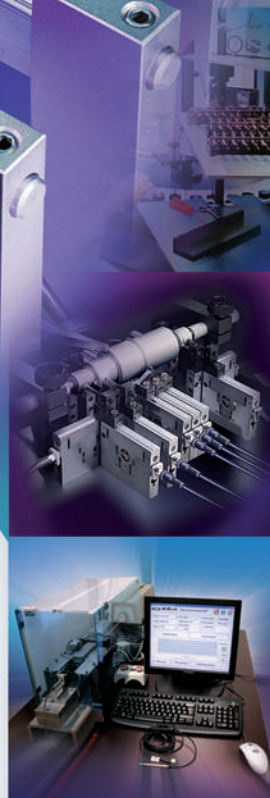
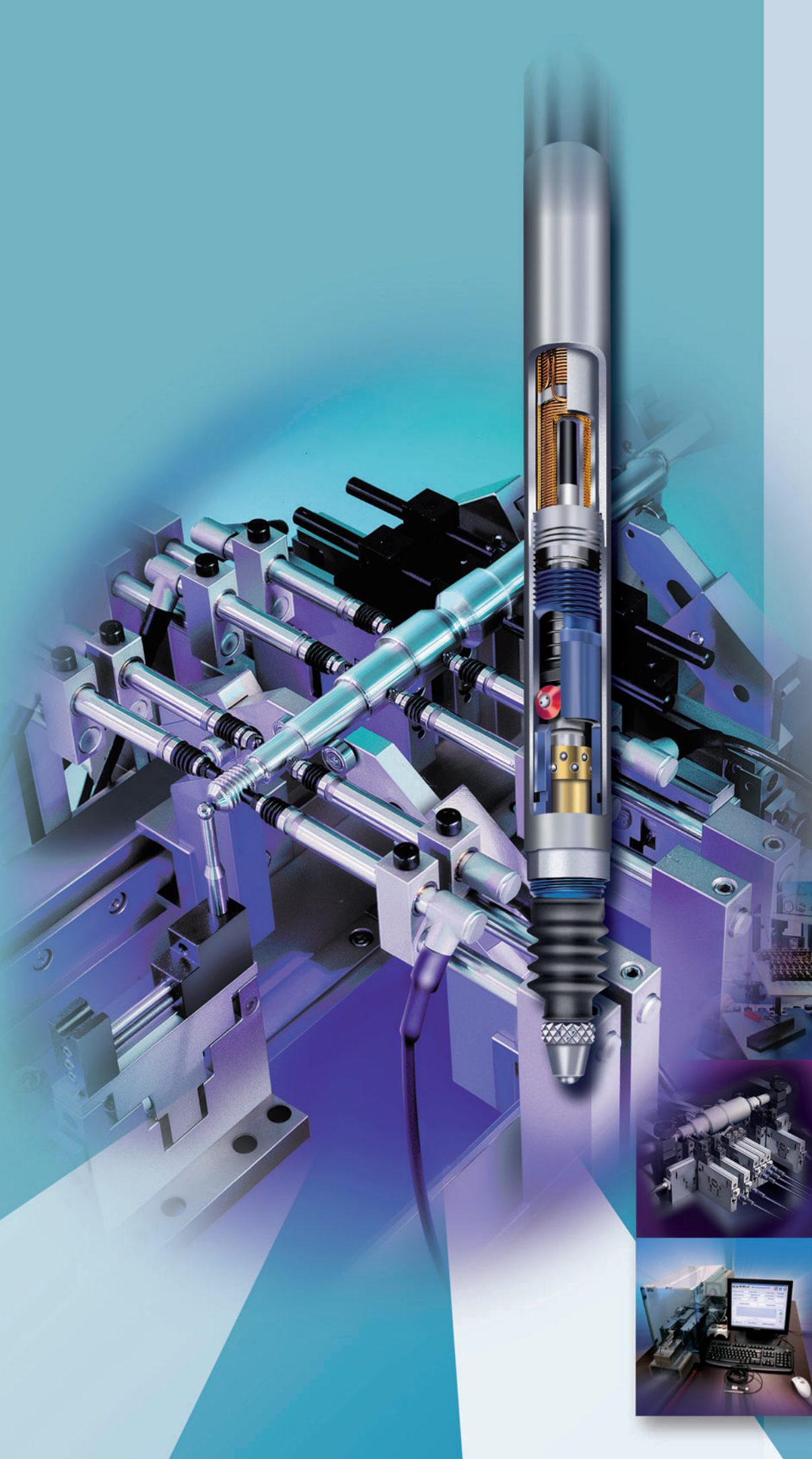

TESA INDUCTIVE PROBES AND ELECTRONIC EQUIPMENT

TESA probes: At the cutting edge of technology

TESA develops, manufactures and remains a leader in the inductive probe sector with an experience of more than 40 years. It offers a complete and unique line of probes designed to meet the requirements of varied as well as demanding applications.

Dimensional inspection of medium and large batches of parts in multigauging fixtures represents a major application area where measuring speed coupled with a high level of accuracy is needed.

High precision inductive probes (type GTL-21 HP) are, for example, also suited for the measurement of gauge blocks. The display resolution can reach a digital step of 0,01 μm !

On request, TESA probes can be supplied in versions compatible with the electronic equipment of other suppliers.

Typical qualities of TESA inductive probes : excellent repeatability, durability and longevity

All TESA inductive axial movement are mounted on a ball bearing with the exception of miniature models.

The ball bearing guidance system is insensitive to any radial force exerted on the probe housing. An anti-rotation guiding system ensures perfect movement of the mechanical guide.

The axial probe guide system is effectively protected against penetration of liquids (oils) or solids (dust) by sealing bellows of high elastic quality. Under normal conditions, the standard nitrile elastomer bellows provide sufficient protection against oils and solvents. For applications where the probes remain in prolonged contact with coolants or lubricants and aggressive chemicals, Viton bellows are recommended. Viton is a fluorelastomer resistant to the heat of oils and aggressive chemicals.

The retraction (lifting) of the measuring bolt rod can be made by the suction of air (vacuum) accumulated within the probe thanks to the airtightness provided by the sealing bellows. This method of working principle does not use any mechanical device ensures the operation of the guidance system in an optimal manner. Similarly, the probe can be moved into its measuring position by a pneumatic activation (pressure), depending on the probe model.

Inserts (measuring inserts) can be replaced or exchanged. A wide choice of geometrical forms and sizes are available

The measuring force can be adjusted by changing the spring, depending on the probe model.

The probes integrate an electronic amplifier of the signal without relying on any mechanical conversion device. Thus, these probes are distinguished by their high repeatability and very low hysteresis errors.

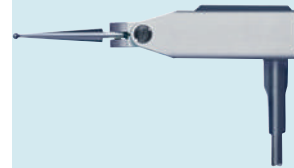
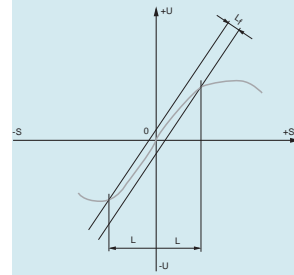

GT-31

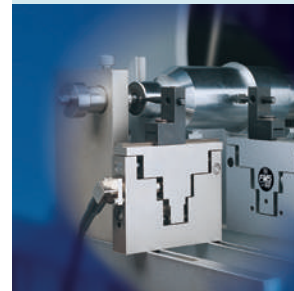

Probe FMS



TT20



USB probe



Wireless probe



Application examples of measuring functions

Measuring external dimensions with use of a measuring stand, snap gauge etc.

Single measurements with positive polarity sign (+A)

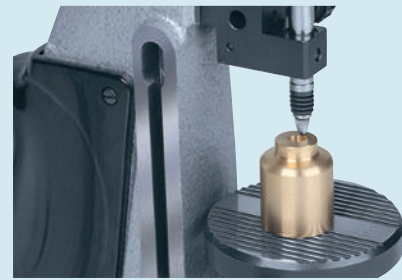
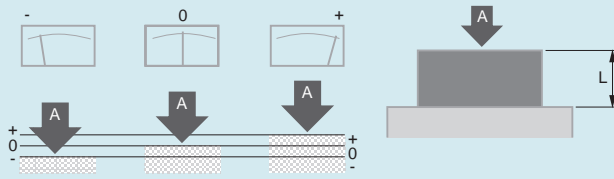

Inversion of polarity with displayed value equal to bore or diameter

Single measurements with negative polarity sign (-A)

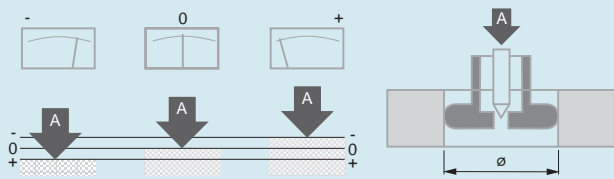

Measuring external dimensions regardless of form and position errors

Sum measurements with positive polarity signs (+A +B)

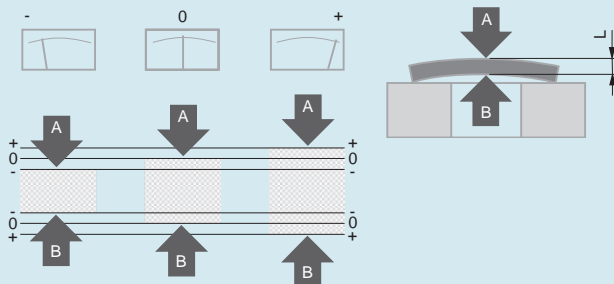

Cone, inclination and step measurements.

Difference measurements with opposite polarity signs (+A -B)

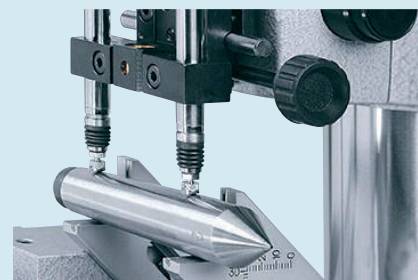
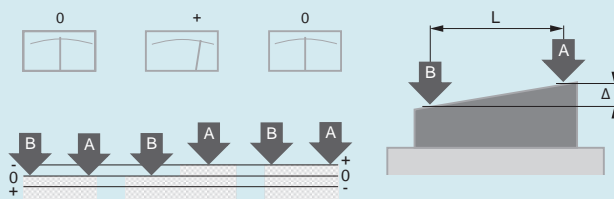

Establishing form and position errors with "max - min" memory function as in the example for runout errors

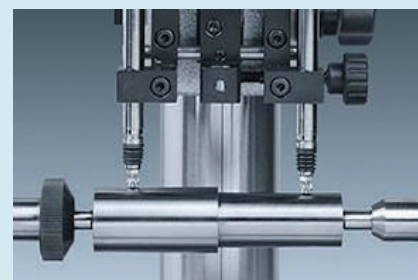
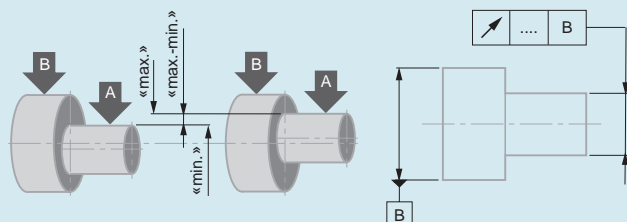

For the acquisition of measured values, TESA offers a complete family of probes and measuring instruments for the most demanding applications. The probes, supplied in standard execution, do not need any form of adaptation. They function on the inductive half-bridge principle.

The market offers other equipment using probes that partly operate on the principle of a differential transformer and these are known as LVDT (Linear Variable Differential Transformer) probes.

TESA also offers a range of probes compatible with other electronic equipment, using an adaptor and a connector depending on the origin of the equipment. A description of TESA standard half-bridge and LVDT probes is provided below.

Standard half-bridge probes for TESA equipment

OPERATING PRINCIPLE

All TESA electronic probes (value sensors) work based on the inductive principle with mechanical contact of the workpiece.

They are fitted with a coil system inducing an alternating output voltage that depends on the the position of the ferro magnetic core. When symmetrically positioned – i.e. at electrical zero – no voltage is impressed. A move of the core, which may be attached to the measuring bolt while the measurand is being taken, causes the inductance to change. This change generates a signal that is amplified and rectified before being displayed and further output. Depending on the instrument type, the analogue signal will be shown on a voltmeter or a numerical display after a digital transformation.

Unambiguous assessment of the measurand (at bolt position) to the signal (displayed value) is the main characteristic of analogue value acquisition. One of its distinct advantages lies in the value primarily displayed, which will be reproduced in the event of a power cut (switch-off or power failure).

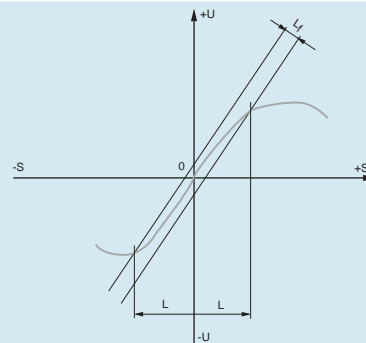

Inductive measuring
 S: Travel
 U: Output current
 0: Electrical zero
 L: Linearity range
 Lf: Linearity error

TESA Standard Half-Bridge Probes for TESA Electronic Equipment

These probes have two serial coils with middle output mounted side by side, which are energized by a sinusoidal alternation signal at 13 kHz. Both are linked together to a Wheatstone bridge over an additional half-bridge.

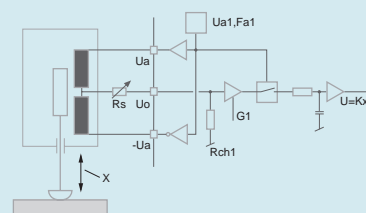

Wiring plan of half-bridge probes

TESA LVDT Probes

These probes are based on a Linear Variable Differential Transformer (LVDT). They have three coils, i.e. one primary coil being energized by a sinusoidal alternation at 5 kHz, and two secondary coils connected in opposite phase, which generate the output current proportional to the measuring travel.

Available upon request.

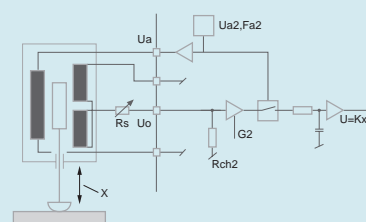

Wiring plan of LVDT probes



Multiple application possibilities

TESA probes have been designed for applications for use with instruments for internal and external measurements, measuring supports or special measuring systems. For such applications, different probe executions can be supplied such as probes with an axial measuring bolt or parallel guides, refer also to angle lever probes. In addition, there are also special executions developed for multi-gauging inspection fixtures or 'in-process' inspection stations, which enable an economy in the number of components needed. Apart from a few exceptions, the measuring operations executed are always comparative measurements with reference to a standard such as a gauge block, a setting ring or any other component that can be used as a master.

The measurements are extremely accurate. Bias error influence is negligible compared to the budget for measuring uncertainty given the fact that the comparison is being established between two almost practically equal values

Random errors also lose their influence in a procedure where the display setting is made under the same conditions as the subsequent probing measurements

TESA measuring instruments are equipped with an analogue and/or digital display, depending on the model.

Internal processing of measured values

Depending on the application, the electrical signals are processed in different ways within the instrument.

Mathematical Data Processing

The signals can be processed with positive polarity sign as well as negative polarity sign. The use of a single probe enables single measurement of internal or external dimensions while the combination of the signals of two probes produces either a "sum measurement" or a "difference measurement".

Value Storage

The storage of measured values in the memory ensures the reliability of dynamic measuring cycles. The characteristic values are the two minimum and maximum values or the difference between the smallest and largest value acquired while measuring form or position errors.

Classification of Values

The measured values can be classified after the entering of limit deviations. In this case, the control signals can be used by an external peripheral unit.

Components of a TESA inductive probe

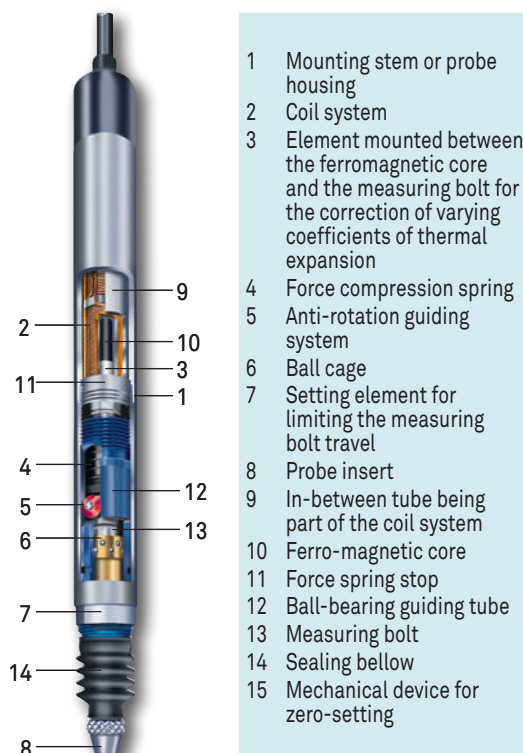

Sensitivity of TESA half-bridge probes for TESA electronic interfaces and electronic displays

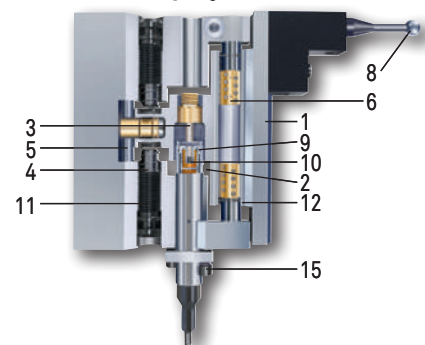

| | |
|---|----------------------------------|
| Sensitivity | 73,75 mV/V/mm |
| | 29,50 mV/V/mm (GT 61, GT 62) |
| | 7,375 mV/V/mm (GT 61S, GT 62S) |
| | 49,17 mV/V/mm (FMS 130, FMS 132) |
| All given values are valid for the following reference conditions : | |
| Drive voltage | 3 V |
| Drive frequency | 13 kHz |
| Adjustment load | 2 kΩ |









Probes with Axial Movement, Ø 8 mm

| |  |  |  |  |  |  |  |
|---|---|---|---|---|---|---|---|
| | No | | Measuring range, mm | Measuring bolt travel, mm | Cable output | Measuring bolt retraction | Sealing bellows |
|  | 03210904 | GT 21 | ± 1 mm | 4,3 | Axial | Mechanical | Nitrile |
|  | 03210924 | GT 22 | ± 1 mm | 4,3 | Radial | Mechanical or vacuum | Nitrile |
|  | 03230057 | GTL 21 | ± 2 mm | 4,3 | Axial | Mechanical | Viton |
|  | 03230072 | GTL 211 | ± 2 mm | 4,3 | Axial | Vacuum | Viton |
|  | 03230056 | GTL 22 | ± 2 mm | 4,3 | Radial | Vacuum | Viton |
|  | 03230027 | GT 27 | ± 2 mm | 10,3 | Axial | Mechanical | Viton |
|  | 03230073 | GT 271 | ± 2 mm | 10,3 | Axial | Mechanical / vacuum | Viton |
|  | 03230026 | GT 28 | ± 2 mm | 10,3 | Radial | Mechanical / vacuum | Viton |
|  | 03230041 | GT 61 | ± 5 mm | 10,3 | Axial | Mechanical | Viton |
|  | 03230042 | GT 62 | ± 5 mm | 10,3 | Radial | Mechanical / vacuum | Viton |
|  | 03230036 | GT 21 HP | ± 0,2 mm | 4,3 | Axial | Mechanical | Nitrile |
|  | 03230021 | GT 22 HP | ± 0,2 mm | 4,3 | Radial | Mechanical or vacuum | Nitrile |



* Nominal value of the measuring force at electrical zero, max. deviation $\pm 25\%$

** For an amplitude of 10 % to the last value of the measuring range

|  Nominal measuring force*, N |  Mobile weight, g |  Mechanical limit max frequency** (Hz) |  Partially removable |  Répeatability, μm |  Max. permissible error for deviations in linearity, μm (L in mm) |  Hysteresis, μm |  Protection level (IP XX), as per IEC 60529 |
|---|--|---|---|--|---|---|--|
| 0,63 | 6 | 60 | Yes | 0,01 μm | $0,2 + 3 \cdot L^3 \mu\text{m}$ | 0,02 | IP65 |
| 0,63 | 6 | 60 | Yes | 0,01 μm | $0,2 + 3 \cdot L^3 \mu\text{m}$ | 0,02 | IP65 |
| 0,63 | 6 | 60 | Yes | 0,01 μm | $0,2 + 2,4 \cdot L^2 \mu\text{m}$ BPX: $0,2 + 0,8 \cdot L \mu\text{m}$ | 0,02 | IP65 |
| 0,63 | 6 | 60 | Yes | 0,01 μm | $0,2 + 2,4 \cdot L^2 \mu\text{m}$ BPX: $0,2 + 0,8 \cdot L \mu\text{m}$ | 0,02 | IP65 |
| 0,63 | 6 | 60 | Yes | 0,01 μm | $0,2 + 2,4 \cdot L^2 \mu\text{m}$ BPX: $0,2 + 0,8 \cdot L \mu\text{m}$ | 0,02 | IP65 |
| 0,63 | 8 | 60 | Yes | 0,05 μm | $0,2 + 3 \cdot L^3 \mu\text{m}$ | 0,05 | IP65 |
| 0,63 | 8 | 60 | Yes | 0,05 μm | $0,2 + 3 \cdot L^3 \mu\text{m}$ | 0,05 | IP65 |
| 0,63 | 8 | 60 | Yes | 0,05 μm | $0,2 + 3 \cdot L^3 \mu\text{m}$ | 0,05 | IP65 |
| 0,90 | 8 | 60 | Yes | 0,05 μm | $1 + 4 \cdot L \mu\text{m}$ BPX: $0,6 + 0,8 \cdot L \mu\text{m}$ | 0,05 | IP65 |
| 0,90 | 8 | 60 | Yes | 0,05 μm | $1 + 4 \cdot L \mu\text{m}$ BPX: $0,6 + 0,8 \cdot L \mu\text{m}$ | 0,05 | IP65 |
| 0,63 | 6 | 60 | No | 0,01 μm | $0,07 + 0,4 \cdot L \mu\text{m}$ | 0,01 | IP64 |
| 0,63 | 6 | 60 | No | 0,01 μm | $0,07 + 0,4 \cdot L \mu\text{m}$ | 0,01 | IP64 |











Probes with Axial Movement, Ø 8 mm, with Activation of the Measuring Bolt by Pneumatic Pressure

| |  |  |  |  |  |  |
|---|---|---|---|---|---|---|
| | | | Measuring range, mm | Measuring bolt travel, mm | Cable output | Sealing bellows |
|  | 03230060 | GTL 212 | ± 1,5 mm | 3,2 | Axial | Viton |
|  | 03230054 | GTL 222 | ± 1,5 mm | 3,2 | Radial | Viton |
|  | 03230067 | GTL 212-A | ± 1,5 mm | 3,2 | Axial | Without bellows |
|  | 03230063 | GTL 222-A | ± 1,5 mm | 3,2 | Radial | Without bellows |
|  | 03230061 | GT 272 | ± 2 mm | 10,3 | Axial | Viton |
|  | 03230053 | GT 282 | ± 2 mm | 10,3 | Radial | Viton |
|  | 03230068 | GT 272-A | ± 2 mm | 10,3 | Axial | Without bellows |
|  | 03230069 | GT 282-A | ± 2 mm | 10,3 | Radial | Without bellows |
|  | 03230062 | GT 612 | ± 5 mm | 10,3 | Axial | Viton |
|  | 03230055 | GT 622 | ± 5 mm | 10,3 | Radial | Viton |
|  | 03230070 | GT 612-A | ± 5 mm | 10,3 | Axial | Without bellows |
|  | 03230071 | GT 622-A | ± 5 mm | 10,3 | Radial | Without bellows |



* Nominal value of the measuring force at electrical zero, max. deviation $\pm 25\%$

** For an amplitude of 10% to the last value of the measuring range

|  Measuring force, nominal*, N |  Mobile weight, g |  Max. mechanical frequency limit** (Hz) |  Partially removable |  Repeatability, μm |  Max. permissible error for deviations in linearity, μm (L in mm) |  Hysteresis, μm |  Protection level (IP XX), as per IEC 60529 |
|--|--|--|---|--|---|---|--|
| 1,2 | 6 | 60 | Yes | 0,015 μm | $0,2 + 2,4 \cdot L^2 \mu\text{m}$ BPX: $0,2 + 0,8 \cdot L \mu\text{m}$ | 0,02 | IP65 |
| 1,2 | 6 | 60 | Yes | 0,015 μm | $0,2 + 2,4 \cdot L^2 \mu\text{m}$ BPX: $0,2 + 0,8 \cdot L \mu\text{m}$ | 0,02 | IP65 |
| 0,2 | 6 | 60 | Yes | 0,015 μm | $0,2 + 2,4 \cdot L^2 \mu\text{m}$ BPX: $0,2 + 0,8 \cdot L \mu\text{m}$ | 0,02 | IP50 |
| 0,2 | 6 | 60 | Yes | 0,015 μm | $0,2 + 2,4 \cdot L^2 \mu\text{m}$ BPX: $0,2 + 0,8 \cdot L \mu\text{m}$ | 0,02 | IP50 |
| 1,0 | 8 | 60 | Yes | 0,05 μm | $0,2 + 3 \cdot L^3 \mu\text{m}$ | 0,05 | IP65 |
| 1,0 | 8 | 60 | Yes | 0,05 μm | $0,2 + 3 \cdot L^3 \mu\text{m}$ | 0,05 | IP65 |
| 0,85 | 8 | 60 | Yes | 0,05 μm | $0,2 + 3 \cdot L^3 \mu\text{m}$ | 0,05 | IP50 |
| 0,85 | 8 | 60 | Yes | 0,05 μm | $0,2 + 3 \cdot L^3 \mu\text{m}$ | 0,05 | IP50 |
| 2,0 | 8 | 60 | Yes | 0,05 μm | $1 + 4 \cdot L \mu\text{m}$ BPX: $0,6 + 0,8 \cdot L \mu\text{m}$ | 0,05 | IP65 |
| 2,0 | 8 | 60 | Yes | 0,05 μm | $1 + 4 \cdot L \mu\text{m}$ BPX: $0,6 + 0,8 \cdot L \mu\text{m}$ | 0,05 | IP65 |
| 1,0 | 8 | 60 | Yes | 0,05 μm | $1 + 4 \cdot L \mu\text{m}$ BPX: $0,6 + 0,8 \cdot L \mu\text{m}$ | 0,05 | IP50 |
| 1,0 | 8 | 60 | Yes | 0,05 μm | $1 + 4 \cdot L \mu\text{m}$ BPX: $0,6 + 0,8 \cdot L \mu\text{m}$ | 0,05 | IP50 |











USB, DC, Wireless Probes

| |  |  |  |  |  |  |  |
|---|---|---|---|---|---|---|---|
| | | | Measuring range, mm | Max. plunger travel, mm | Cable output | Bolt retraction | Sealing bellows |
|  | 03230500 | GTL 21 W | ± 2 mm | 4,3 | Without cable | Mechanical | Viton |
|  | 03230502 | GT61 W | ± 5 mm | 10,3 | Without cable | Mechanical | Viton |
| | 03230501 | GTL 212 W | ± 1,5 mm | 4,3 | Without cable | Pressure (bolt activation), below spring (bolt retraction) | Viton |
| | 03230503 | GT 612 W | ± 5 mm | 10,3 | Without cable | Pressure (bolt activation), below spring (bolt retraction) | Viton |
| | 03230201 | GTL 22 USB | ± 2 mm | 4,3 | Radial | Mechanical | Viton |
| | 03230200 | GTL 21 USB | ± 2 mm | 4,3 | Axial | Mechanical | Viton |
| | 03230204 | GT 61 USB | ± 5 mm | 10,3 | Axial | Mechanical | Viton |
| | 03230205 | GT 62 USB | ± 5 mm | 10,3 | Radial | Mechanical / vacuum | Viton |
| | 03230202 | GTL 222 USB | ± 1,5 mm | 3,1 | Radial | Pressure (bolt activation), below spring (bolt retraction) | Viton |
| | 03230058 | GTL 22 DC | ± 2 mm | 4,3 | Radial | Mechanical / vacuum | Viton |
| | 03230059 | GTL 21 DC | ± 2 mm | 4,3 | Axial | Mechanical | Viton |
| | 03230087 | GT 62 DC | ± 5 mm | 10,3 | Radial | Mechanical / vacuum | Viton |
| | 03230086 | GT 61 DC | ± 5 mm | 10,3 | Axial | Mechanical | Viton |
| | 03230085 | GT 44 DC | ± 1 mm | 2,1 | Radial | Mechanical / vacuum | Viton |
| | 03230081 | GT 31 DC | ± 0,3 mm | 0,7 | Angled | Without retraction | Without bellows |













* Nominal value of the measuring force at electrical zero, max. deviation $\pm 25\%$

** For an amplitude of 10% to the last value of the measuring range



|  Nominal measuring force*, N |  Mobile weight, g |  Max. mechanical frequency limit**, (Hz) |  Partially removable |  Repeatability, μm |  Maximum permissible error, μm (L in mm) |  Hysteresis, μm |  Level of protection (IP XX), as per IEC 60529 |
|---|--|---|---|--|--|---|---|
| 0,63 | 6 | 60 | No | 0,10 μm | $0,4 + 0,8 \cdot L \mu\text{m}$ | 0,5 | IP54 |
| 0,9 | 8 | 60 | No | 0,24 μm | $0,8 + 0,8 \cdot L \mu\text{m}$ | 0,5 | IP54 |
| 1,2 | 6 | 60 | No | 0,10 μm | $0,4 + 0,8 \cdot L \mu\text{m}$ | 0,5 | IP54 |
| 2,0 | 8 | 60 | No | 0,24 μm | $0,8 + 0,8 \cdot L \mu\text{m}$ | 0,5 | IP54 |
| 0,63 | 6 | 60 | No | 0,1 μm | $0,4 + 0,8 \cdot L \mu\text{m}$ | 0,5 | IP65 |
| 0,63 | 6 | 60 | No | 0,1 μm | $0,4 + 0,8 \cdot L \mu\text{m}$ | 0,5 | IP65 |
| 0,90 | 8 | 60 | No | 0,24 μm | $0,8 + 0,8 \cdot L \mu\text{m}$ | 0,5 | IP65 |
| 0,90 | 8 | 60 | No | 0,24 μm | $0,8 + 0,8 \cdot L \mu\text{m}$ | 0,5 | IP65 |
| 1,2 | 6 | 60 | No | 0,1 μm | $0,4 + 0,8 \cdot L \mu\text{m}$ | 0,5 | IP64 |
| 0,63 | 6 | 60 | Yes | 0,1 μm | $0,2 + 3,5 \cdot L^2 \mu\text{m}$ | | IP65 |
| 0,63 | 6 | 60 | Yes | 0,1 μm | $0,2 + 3,5 \cdot L^2 \mu\text{m}$ | | IP65 |
| 0,9 | 8 | 60 | No | 0,1 μm | $1 + 4 \cdot L \mu\text{m}$ | | IP65 |
| 0,9 | 8 | 60 | Yes | 0,1 μm | $1 + 4 \cdot L \mu\text{m}$ | | IP65 |
| 0,4 | 2 | 60 | No | 0,1 μm | $0,2 + 5 \cdot L^2 \mu\text{m}$ | | IP65 |
| 0,1 | 12 | 25 | No | 0,1 μm | $0,2 + 50 \cdot L^2 \mu\text{m}$ | | IP50 |

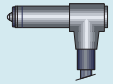

Probes with Axial Movement, Ø 8 mm

| |  |  |  |  |  |  |  |
|---|---|---|---|---|---|---|---|
| | | | Measuring range, mm | Measuring bolt travel, mm | Cable output | Bolt retraction | Sealing bellows |
|  | 03230001 | GT 41 | ± 0,3 mm | 0,7 | Axial | None | Nitrile |
|  | 03230002 | GT 42 | ± 0,3 mm | 0,7 | Radial | Vacuum | Nitrile |
|  | 03230035 | GT 43 | ± 1 mm | 2,1 | Axial | Mechanical | Viton |
|  | 03230017 | GT 44 | ± 1 mm | 2,1 | Radial | Vacuum | Viton |

Unbranded Axial Probes with Measuring Bolt Mounted on a Ball-bearing

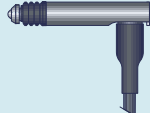
| | | | | | | | |
|---|----------|-----|----------|------|------------------|------------|---------|
|  | 96410012 | 410 | ± 1 mm | 2,5 | Axial and radial | Mechanical | Nitrile |
|  | 96160013 | 160 | ± 1 mm | 3,3 | Axial | Mechanical | Viton |
|  | 96430029 | 430 | ± 0,5 mm | 1,25 | Axial | Mechanical | Nitrile |
|  | 96441041 | 451 | ± 0,5 mm | 2,10 | Radial | Mechanical | Nitrile |



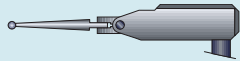





Probe with Inclinable Lever

| | | | | | | | |
|---|----------|-------|----------|-----|--------|---------|-----------------|
|  | 03210802 | GT 31 | ± 0,3 mm | 0,7 | Angled | Without | Without bellows |
|---|----------|-------|----------|-----|--------|---------|-----------------|



* Nominal value of the measuring force at electrical zero, max. deviation $\pm 25\%$

** For an amplitude of 10 % to the last value of the measuring range

|  Nominal measuring force*, N |  Mobile weight, g |  Max. mechanical frequency limit**, (Hz) |  Partially removable |  Repeatability, μm |  Max. permissible error for deviations in linearity, μm (L en mm) |  Hysteresis, μm |  Level of protection (IP XX), as per IEC 60529 |
|---|--|---|---|--|--|---|---|
| 0,63 | 2 | 60 | No | 0,01 μm | $0,2 + 5 \cdot L^2 \mu\text{m}$ | 0,01 | IP65 |
| 0,63 | 2 | 60 | No | 0,01 μm | $0,2 + 5 \cdot L^2 \mu\text{m}$ | 0,01 | IP65 |
| 0,4 | 2 | 60 | No | 0,1 μm | $0,2 + 5 \cdot L^2 \mu\text{m}$ | 0,15 | IP65 |
| 0,4 | 2 | 60 | No | 0,1 μm | $0,2 + 5 \cdot L^2 \mu\text{m}$ | 0,15 | IP65 |

| | | | | | | | |
|------|-----|----|----|-------------------|--|--|------|
| 0,60 | 3,1 | 60 | No | 0,1 μm | 0,2 % (for a measuring span of ± 1 mm) μm | | IP62 |
| 0,60 | 2,5 | 60 | No | 0,1 μm | 0,2 % (for a measuring span of ± 1 mm) μm | | IP62 |
| 0,75 | 1,9 | 60 | No | 0,2 μm | 0,2 % (for a measuring span of $\pm 0,5$ mm) μm | | IP62 |
| 0,60 | 3,0 | 60 | No | 0,1 μm | 0,2 % (for a measuring span of $\pm 0,5$ mm) μm | | IP62 |

| | | | | | | | |
|-----|----|----|----|-------------------|----------------------------------|------|------|
| 0,1 | 12 | 25 | No | 0,1 μm | $0,2 + 50 \cdot L^2 \mu\text{m}$ | 0,25 | IP40 |
|-----|----|----|----|-------------------|----------------------------------|------|------|











Universal FMS Probes

| |  |  |  |  |  |  |  |
|---|---|---|---|---|---|---|---|
| | No | = | Measuring range, mm | Measuring bolt travel, mm | Cable output | Bolt retraction | Sealing bellows |
|  | 03230019 | FMS 100 | ± 2 mm | 5,8 | Parallel | Retraction by air pressure (optional) | Without bellows |
|  | 03230049 | FMS 130 | ± 2,9 mm | 5,8 | Parallel | Retraction by air pressure (optional) | Without bellows |
|  | 03230028 | FMS 102 | ± 2 mm | 5,8 | Parallel | Retraction by air pressure (optional) | Without bellows |
|  | 03230050 | FMS 132 | ± 2,9 mm | 5,8 | Parallel | Retraction by air pressure (optional) | Without bellows |
|  | 03230037 | FMS100-P | ± 2 mm | 5,8 | Parallel | Retraction by air pressure (optional) | Without bellows |
|  | 03230051 | FMS130-P | ± 2,9 mm | 5,8 | Parallel | Retraction by air pressure (optional) | Without bellows |
|  | 03230038 | FMS102-P | ± 2 mm | 5,8 | Angled | Retraction through air pressure (optional) | Without bellows |
|  | 03230052 | FMS132-P | ± 2,9 mm | 5,8 | Angled | Retraction through air pressure (optional) | Without bellows |



* Nominal value of the measuring force at electrical zero, max. deviation $\pm 25\%$

** For an amplitude of 10% to the last value of the measuring range

|  Nominal measuring force*, N |  Mobile weight, g |  Max. mechanical frequency limit**, Hz |  Partially removable |  Repeatability, μm |  Max. permissible error for deviation in linearity, μm (L in mm) |  Hysteresis, μm |  Protection level (IP XX), as per IEC 60529 |
|---|--|---|---|--|--|---|--|
| 2 | 110 | 25 | Yes | 0,5 μm | 0,2 + 3 · L ³ μm | 0,5 | IP50 |
| 2 | 110 | 25 | Yes | 0,5 μm | 0,2 + 3 · L ³ μm | 0,5 | IP50 |
| 2 | 110 | 25 | Yes | 0,5 μm | 0,2 + 3 · L ³ μm | 0,5 | IP50 |
| 2 | 110 | 25 | Yes | 0,5 μm | 0,2 + 3 · L ³ μm | 0,5 | IP50 |
| 2 | 110 | 25 | Yes | 0,5 μm | 0,2 + 3 · L ³ μm | 0,5 | IP54 |
| 2 | 110 | 25 | Yes | 0,5 μm | 0,2 + 3 · L ³ μm | 0,5 | IP54 |
| 2 | 110 | 25 | Yes | 0,5 μm | 0,2 + 3 · L ³ μm | 0,5 | IP54 |
| 2 | 110 | 25 | Yes | 0,5 μm | 0,2 + 3 · L ³ μm | 0,5 | IP54 |



Standard Probes, ± 1 mm, 4,3 mm Travel (GT21)

Universal probes for standard and continuous use applications.

- 8 mm diameter probe housing. Can be clamped over its entire length.
- Measuring bolt mounted on a ball bearing.
- Both the probe housing and ball-bearing guide are separate from one another, so that the measuring bolt moves easily even if the probe is not clamped appropriately.
- Degree of protection IP65 according to IEC 60529.
- Wide range of accessories including measuring inserts, spring sets, etc.
- LVDT probes compatible with measuring equipment from other makers available on request.



GT21

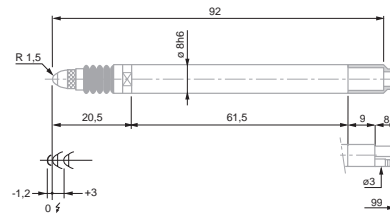

GT 21

| No | = | Measuring range, mm | Nominal measuring force*, N | Measuring bolt retraction | Sealing bellows |
|----------|-------|---------------------|-----------------------------|---------------------------|-----------------|
| 03210904 | GT 21 | ± 1 | 0,63 | Mechanical | Nitrile |
| 03210905 | GT 21 | ± 1 | 1,00 | Mechanical | Nitrile |
| 03210906 | GT 21 | ± 1 | 1,60 | Mechanical | Nitrile |
| 03210907 | GT 21 | ± 1 | 2,50 | Mechanical | Nitrile |
| 03210908 | GT 21 | ± 1 | 4,00 | Mechanical | Nitrile |

| | = | Measuring bolt travel, mm | Max. permissible error for deviations in linearity, µm (L in mm) | Repeatability, µm | Hysteresis, µm | Setting of the lower bolt stop***, mm (factory setting) | Cable output | Data Sheet No. |
|-------|-----|---------------------------|--|-------------------|------------------------------------|---|--------------|----------------|
| GT 21 | 4,3 | 0,2 + 3 · L ³ | 0,01 | 0,02 | -2,2 to 0,1 (factory setting -1,2) | Axial | 03200249 | |

* Electrical zero (N) ± 25 % deviation limit. Valid in vertical mounting position, measuring bolt lowered and in static measuring.

** For an amplitude of 10 % to the last value of the measuring range.

*** Distance from electrical zero.



DIN 32876 Part 1



See table



Nickel-plated housing. Stainless steel measuring bolt, hardened. Nitrile sealing bellows = resistant elastomer



Fixing shank Ø 8 mm. Measuring bolt guided on ball-bearing. Distance from electrical zero of both stops is either adjustable (downward) or depending on the position of the lower stop (upward). Interchangeable inserts. M2,5 thread. Carbide ball tip Ø 3 mm. 2 m long cable. 5-pin DIN 45322 connector.



Supply frequency: 13 kHz (± 5 %). Max mechanical frequency** 60 Hz.



0,15 µm/°C



20 ± 0,5°C



-10°C to 65°C



80 %



Protection level IP65 (IEC 60529)



Mobile weight: 6 g



Transport packaging



Identification number



Inspection report with a declaration of conformity



Standard Probes, ± 1 mm, 4,3 mm Travel (GT22)

Universal probes for common but constraining applications.

- 8 mm diameter probe housing. Can be clamped over its entire length.
- Measuring bolt mounted on a ball bearing.
- Both the probe housing and ball-bearing guide are separate from one another, so that the measuring bolt moves easily even if the probe is not clamped appropriately.
- Degree of protection IP65 according to IEC 60529.
- Wide range of accessories including measuring inserts, spring sets, etc.
- LVDT probes compatible with measuring equipment from other makers available on request.

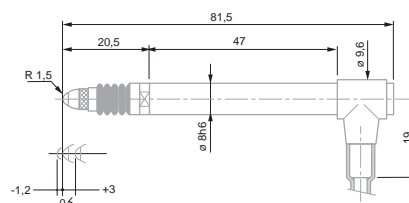

GT 22

GT 22

- DIN 32876 Part 1
- See table
- Nickel-plated housing. Stainless steel measuring bolt, hardened. Nitrile sealing bellows = resistant elastomer
- Fixing shank Ø 8 mm. Measuring bolt guided on ball-bearing. Distance from electrical zero of both stops is either adjustable (downward) or depending on the position of the lower stop (upward). Interchangeable inserts. M2,5 thread. Carbide ball tip Ø 3 mm. 2 m long cable. 5-pin DIN 45322 connector.
- Supply frequency: 13 kHz (± 5 %). Max mechanical frequency** 60 Hz.
- 0,15 µm/°C
- 20 ± 0,5°C
- 10°C to 65°C
- 80 %
- Protection level IP65 (IEC 60529)
- Mobile weight: 6 g
- Transport packaging
- Identification number
- Inspection report with a declaration of conformity

| | | Measuring range, mm | Nominal measuring force*, N | Measuring bolt retraction | Sealing bellows |
|----------|-------|---------------------|-----------------------------|---------------------------|-----------------|
| 03210924 | GT 22 | ± 1 | 0,63 | Mechanical or vacuum | Nitrile |
| 03210921 | GT 22 | ± 1 | 0,16 | Mechanical or vacuum | Nitrile |
| 03210922 | GT 22 | ± 1 | 0,25 | Mechanical or vacuum | Nitrile |
| 03210923 | GT 22 | ± 1 | 0,40 | Mechanical or vacuum | Nitrile |
| 03210925 | GT 22 | ± 1 | 1,00 | Mechanical | Nitrile |
| 03210926 | GT 22 | ± 1 | 1,60 | Mechanical | Nitrile |
| 03210927 | GT 22 | ± 1 | 2,50 | Mechanical | Nitrile |
| 03210928 | GT 22 | ± 1 | 4,00 | Mechanical | Nitrile |

| | Measuring travel, mm | Max. permissible error for deviations in linearity, µm (L in mm) | Repeatability, µm | Hysteresis, µm | Setting of the lower bolt stop***, mm (factory setting) | Cable output | Data Sheet No. |
|-------|----------------------|--|-------------------|----------------|---|--------------|----------------|
| GT 22 | 4,3 | 0,2 + 3 · L ³ | 0,01 | 0,02 | -2,2 to 0,1 (factory setting -1,2) | Radial | 03200250 |

* Electrical zero (N) ± 25 % deviation limit. Valid in vertical mounting position, measuring bolt lowered and in static measuring.

** For an amplitude of 10 % to the last value of the measuring range.

*** Distance from electrical zero.



Standard Probes ± 2 mm, 4,3mm Bolt Travel, Linear Travel

Universal probes for standard and continual usage applications.

- Probe housing Ø 8 mm with possibility of clamping over its entire length.
- Measuring bolt mounted on a ball bearing.
- Both the probe housing and ball-bearing guide are separate from one another, so that the measuring bolt moves easily even if the probe is not clamped appropriately.
- Degree of protection IP65 according to IEC 60529.
- Wide range of accessories including measuring inserts, spring sets, etc.
- LVDT probes compatible with measuring equipment from other makers available on request.

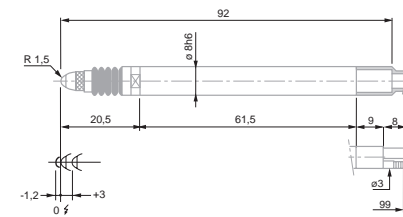

GTL 21
GTL 211

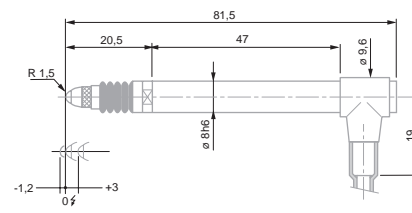

GTL 22



GTL 21
GTL 211



GTL 22

| No | = | Measuring range, mm | Nominal measuring force*, N | Measuring bolt retraction | Sealing bellows |
|----------|---------|---------------------|-----------------------------|---------------------------|-----------------|
| 03230057 | GTL 21 | ± 2 | 0,63 | Mechanical | Viton |
| 03230072 | GTL 211 | ± 2 | 0,63 | Vacuum | Viton |
| 03230056 | GTL 22 | ± 2 | 0,63 | Vacuum | Viton |

| | Measuring bolt travel, mm | Max. permissible error for deviation in linearity, µm (L in mm) | Repeatability, µm | Hysteresis, µm | Setting of measuring bolt lower stop***, mm (factory setting) | Cable output | Data Sheet No. |
|---------|---------------------------|---|-------------------|----------------|---|--------------|----------------|
| GTL 21 | 4,3 | 0,2 + 2,4 · L ² (BPX: 0,2 + 0,8 · L) | 0,01 | 0,02 | -2,2 to 0,1 (factory setting -1,2) | Axial | 03200391 |
| GTL 211 | 4,3 | 0,2 + 2,4 · L ² (BPX: 0,2 + 0,8 · L) | 0,01 | 0,02 | -2,2 to 0,1 (factory setting -1,2) | Axial | 03200435 |
| GTL 22 | 4,3 | 0,2 + 2,4 · L ² (BPX: 0,2 + 0,8 · L) | 0,01 | 0,02 | -2,2 to 0,1 (factory setting -1,2) | Radial | 03200392 |

* Electrical zero (N) ± 25 % deviation limit. Valid in vertical mounting position, measuring bolt lowered and in static measuring.

** For an amplitude of 10 % to the last value of the measuring range.

*** Distance from electrical zero.



DIN 32876 Part 1



See table



Nickel-plated housing, Stainless steel measuring bolt, hardened. Viton sealing bellows = highly resistant fluor elastomer



Fixing shank Ø 8 mm. Measuring bolt guided on ball-bearing. Distance from electrical zero of both stops is either adjustable (downward) or depending on the position of the lower stop (upward). Interchangeable inserts. M2,5 thread. Carbide ball tip Ø 3 mm. 2 m long cable, 5-pin DIN 45322 connector.



Supply frequency: 13 kHz (± 5 %) Max. mechanical frequency** 60 Hz.



0,2 µm/°C



20 ± 0,5°C



-10°C to 65°C



80 %



Protection level IP65 (IEC 60529)



Mobile weight: 6 g



Transport packaging



Identification number



Inspection report with a declaration of conformity



Standard Probes, ± 2 mm, 10,3 mm Travel, with Long Retraction Travel

Universal inductive probes for various applications, especially for use with multi-gauging inspection fixtures.

- Long retraction travel to prevent the probe from being damaged.
- Protection level IP65 as per IEC 60529.
- Large choice of accessories: measuring inserts, spring sets, etc.
- LVDT probes compatible with measuring equipment from other suppliers also available on request.



DIN 32876 Part 1



See table



Nickel-plated housing. Stainless steel measuring bolt, hardened. Viton bellows = high-resistance fluor elastomer



Fixing shank Ø 8 mm. Measuring bolt guided on ball-bearing. Distance from electrical zero of both stops is either adjustable (downward) or depending on the position of the lower stop (upward). Interchangeable inserts. M2,5 thread. Carbide ball tip Ø 3 mm. 2 m long cable. 5-pin DIN 45322 connector.



Supply frequency: 13 kHz (± 5 %) Max. mechanical frequency** 60 Hz.



0,15 µm/°C



20 ± 0,5°C



-10°C to 65°C



80 %



Protection level IP65 (IEC 60529)



Mobile weight: 8 g



Transport packaging



Identification number



Inspection report with a declaration of conformity



GT 27



GT 271



GT 28

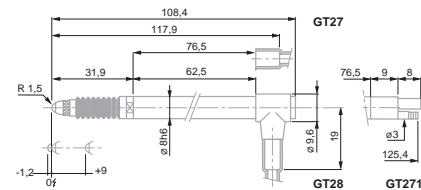

GT 27/ 28
GT 271

| No | = | Table | Hand | Lightning bolt | Sealing bellows |
|----------|--------|---------------------|-----------------------------|---------------------------|-----------------|
| | | Measuring range, mm | Nominal measuring force*, N | Measuring bolt retraction | Sealing bellows |
| 03230027 | GT 27 | ± 2 | 0,63 | Mechanical | Viton |
| 03230073 | GT 271 | ± 2 | 0,63 | Mechanical / vacuum | Viton |
| 03230026 | GT 28 | ± 2 | 0,63 | Mechanical / vacuum | Viton |

| = | Table | 0↔ | ↕ | ↔ | A | Lightning bolt | Warning |
|---------------------------|--|--------------------------|----------------|---|------------------------------------|----------------|----------|
| Measuring bolt travel, mm | Max. permissible error for deviations in linearity, µm (L in mm) | Repeatability, µm | Hysteresis, µm | Setting of measuring bolt lower stop***, mm (factory setting) | Cable output | Data Sheet No. | |
| GT 27 | 10,3 | 0,2 + 3 · L ³ | 0,05 | 0,05 | -2,2 to 0,1 (factory setting -1,2) | Axial | 03200251 |
| GT 271 | 10,3 | 0,2 + 3 · L ³ | 0,05 | 0,05 | -2,2 to 0,1 (factory setting -1,2) | Axial | 03200436 |
| GT 28 | 10,3 | 0,2 + 3 · L ³ | 0,05 | 0,05 | -2,2 to 0,1 (factory setting -1,2) | Radial | 03200252 |

* Electrical zero (N) ± 25 % deviation limit. Valid in vertical mounting position, measuring bolt lowered and in static measuring.

** For an amplitude of 10 % to the last value of the measuring range.

*** Distance from electrical zero



Standard Probes ± 5 mm, 10,3 mm Bolt Travel, Extended Range

- Designed for long measuring travels and low resolution of values
- Specially suited for use on multigauging inspection fixtures.
- Correction factor applied to get the true value is 2,5x (10x for the S probe version).
- Protection level IP 65 as per IEC 60529.
- Large choice of accessories: Measuring inserts, spring sets, etc.
- LVDT probes compatible with measuring equipment from other suppliers also available on request.



GT 61



GT 62

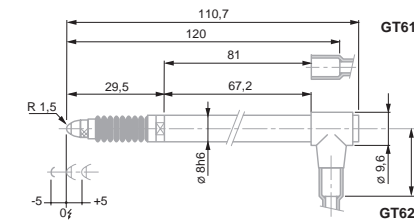

GT 61 / GT 62

| | | Measuring range, mm | Nominal measuring force*, N | Measuring bolt retraction | Sealing bellows | |
|----------|-------|---------------------|-----------------------------|---------------------------|-----------------|--|
| 03230041 | GT 61 | ± 5 | 0,90 | Mechanical | Viton | |
| 03230042 | GT 62 | ± 5 | 0,90 | Mechanical / vacuum | Viton | |

| | Measuring bolt travel, mm | Max. permissible error for deviations in linearity, µm (L in mm) | Repeatability, µm | Hysteresis, µm | Measuring bolt***, mm (factory setting) | Cable output | Data Sheet No. |
|-------|---------------------------|--|-------------------|----------------|--|--------------|----------------|
| GT 61 | 10,3 | 1 + 4 · L (BPX: 0,2 + 0,8 · L) | 0,05 | 0,05 | Lower - 5,1 upper + 5,2 (factory setting -5) | Axial | 03200294 |
| GT 62 | 10,3 | 1 + 4 · L (BPX: 0,2 + 0,8 · L) | 0,05 | 0,05 | Lower - 5,1 upper + 5,2 (factory setting -5) | Radial | 03200295 |

* Electrical zero (N) ± 25 % deviation limit. Valid in vertical mounting position, measuring bolt lowered and in static measuring.
 ** For an amplitude of 10 % to the last value of the measuring range.
 *** Distance from electrical zero.

- DIN 32876 Part 1
- See table
- Nickel-plated housing, Stainless steel measuring bolt, hardened. Viton bellows = highly resistant fluoroe-lastomer
- Fixing shank Ø 8 mm. Measuring bolt guided on ball-bearing. Distance from electrical zero of both stops is either adjustable (downward) or depending on the position of the lower stop (upward). Interchangeable inserts. M2,5 thread. Carbide ball tip Ø 3 mm. 2 m long cable, 5-pin DIN 45322 connector.
- Supply frequency: 13 kHz (± 5 %) Max. mechanical frequency** 60 Hz.
- 0,09 µm/°C
- 20 ± 0,5°C
- 10°C to 65°C
- 80 %
- Protection level IP65 (IEC 60529)
- Mobile weight: 8 g
- Transport packaging
- Identification number
- Inspection report with a declaration of conformity



GT 21 HP High Precision Probes, ± 0,2 mm, 4,3 mm Travel

- Universal probe for common and continuous use applications.
- Very high precision probe suited for the measurement of gauge blocks.
- 8 mm diameter probe housing. Can be clamped over its entire length.
- Measuring bolt mounted on a ball bearing.
- Both the probe housing and ball-bearing guide are separate from one another, so that the measuring bolt moves easily even if the probe is not clamped appropriately.
- Level of protection IP65 according to IEC 60529.
- Wide range of accessories including measuring inserts, spring sets, etc.
- LVDT probes compatible with measuring equipment from other makers available on request.



GT 21 HP

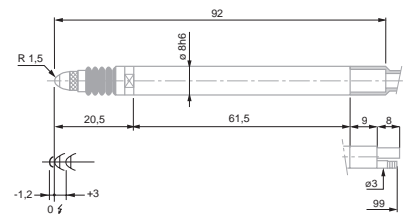

GT 21 HP

- DIN 32876 Part 1
- See table
- Nickel-plated housing. Stainless steel measuring bolt, hardened. Nitrile sealing bellow = resistant elastomer
- Fixing shank Ø 8 mm. Measuring bolt guided on ball-bearing. Distance from electrical zero of both stops is either adjustable (downward) or depending on the position of the lower stop (upward). Interchangeable inserts. M2,5 thread. Carbide ball tip Ø 3 mm. 2 m long cable. 5-pin DIN 45322 connector.
- Supply frequency: 13 kHz (± 5 %) Max. mechanical frequency** 60 Hz.
- 0,15 µm/°C
- 20 ± 0,5°C
- 10°C to 40°C
- 80 %
- Protection level IP65 (IEC 60529)
- Mobile weight: 6 g
- Transport packaging
- Identification number
- Inspection report with a declaration of conformity

| 03230036 | GT 21 HP | Measuring range, mm | Measuring force, nominal*, N | Bolt retraction | Sealing bellows |
|----------|----------|---------------------|------------------------------|-----------------|-----------------|
| | | ± 0,2 | 0,63 | Mechanical | Nitrile |

| GT 21 HP | Measuring bolt travel, mm | Max. permissible error for deviations in linearity, µm (L in mm) | Repeatability, µm | Hysteresis, µm | Setting of lower stop of measuring bolt***, mm (factory setting) | Cable output | Data Sheet No. |
|----------|---------------------------|--|-------------------|----------------|--|--------------|----------------|
| | 4,3 | 07 + 0,4 · L | 0,01 | 0,01 | -2,2 to +0,1 (factory setting -1,2) | Axial | 03200264 |

* Electrical zero (N) ± 25 % deviation limit. Valid in vertical mounting position, measuring bolt lowered and in static measuring.
 ** For an amplitude of 10 % to the last value of the measuring range.
 *** Distance from electrical zero.



GT 22 HP High Precision Probe, ± 0,2 mm, 4,3 mm Travel

Universal probe for standard and continuous use applications.

- Very high precision probe suitable for the measurement of gauge blocks.
- 8 mm diameter probe housing. Can be clamped over its entire length.
- Measuring bolt mounted on a ball bearing.
- Both the probe housing and ball-bearing guide are separate from one another, so that the measuring bolt moves easily even if the probe is not clamped appropriately.
- Level of protection IP65 according to IEC 60529.
- Wide range of accessories including measuring inserts, spring sets, etc.
- LVDT probes compatible with measuring equipment from other makers available on request.



GT 22 HP

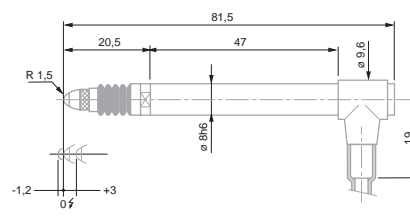

GT 22 HP

| | | | | | |
|----------|----------|---------------------|------------------------------|----------------------|-----------------|
| | | | | | |
| | | Measuring range, mm | Measuring force, nominal*, N | Bolt retraction | Sealing bellows |
| 03230021 | GT 22 HP | ± 0,2 | 0,63 | Mechanical or vacuum | Nitrile |

| | | | | | | | |
|----------------------|--|-------------------|----------------|--|---------------------------|----------------|----------|
| | | | | | | | |
| Measuring travel, mm | Max. permissible error for deviations in linearity, µm (L in mm) | Repeatability, µm | Hysteresis, µm | Setting of lower stop of the measuring bolt***, mm (factory setting) | Cable output | Data Sheet No. | |
| GT 22 HP | 4,3 | 0,07 + 0,4 · L | 0,01 | 0,01 | -2,2 to +0,1 (usine -1,2) | Radial | 03200265 |

* Electrical zero (N) ± 25 % deviation limit. Valid in vertical mounting position, measuring bolt lowered and in static measuring.

** For an amplitude of 10 % to the last value of the measuring range.

*** Distance from electrical zero.



DIN 32876 Part 1



See table



Nickel-plated housing. Stainless steel measuring bolt, hardened. Nitrile sealing bellows = resistant elastomer



Fixing shank Ø 8 mm. Measuring bolt guided on ball-bearing. Distance from electrical zero of both stops is either adjustable (downward) or depending on the position of the lower stop (upward). Interchangeable inserts. M2,5 thread. Carbide ball tip Ø 3 mm. 2 m long cable. 5-pin DIN 45322 connector.



Supply frequency: 13 kHz (± 5 %) Max. mechanical frequency*** 60 Hz.



0,15 µm/°C



20 ± 0,5°C



10°C to 40°C



80 %



Protection level IP65 (IEC 60529)



Mobile weight: 6 g



Transport packaging



Identification number



Inspection report with a declaration of conformity



Pneumatic Probes ± 1,5 mm, 3,2 mm Bolt Travel, Linear

Probes for use with measuring fixtures or inspection machines integrating semi-automated or automated measuring routines.

- 8 mm diameter probe housing. Can be clamped over its entire length.
- Measuring bolt mounted on a ball bearing.
- Both the probe housing and ball-bearing guide are separate from one another, so that the measuring bolt moves easily even if the probe is not clamped appropriately.
- Degree of protection IP65 according to IEC 60529.
- Wide range of accessories including measuring inserts, etc.
- LVDT probes compatible with measuring equipment from other makers available on request.

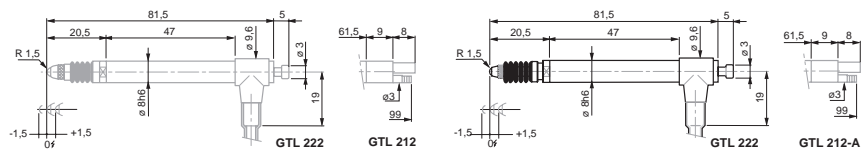

GTL 222



GTL 212



GTL 212-A



GTL 222-A



DIN 32876 Part 1



See table



Nickel-plated housing. Stainless steel measuring bolt, hardened. Viton sealing bellow = highly resistant fluoroelelastomer



Fixing shank Ø 8 mm. Measuring bolt guided on ball-bearing. Distance from electrical zero of both stops is either adjustable (downward) or depending on the position of the lower stop (upward). Interchangeable inserts. M2,5 thread. Carbide ball tip Ø 3 mm. 2 m long cable. 5-pin DIN 45322 connector.



Supply frequency: 13 kHz (± 5 %) Max. mechanical frequency** 60 Hz.



0,2 µm/°C



20 ± 0,5°C



-10°C to 65°C



80 %



Protection level: IP65 (IEC 60529) or IP50 for GTL 212-A and GTL 222-A



Mobile weight: 6 g



Transport packaging



Identification number



Inspection report with a declaration of conformity

| No | = | Table | Hand | Star | Star | Star |
|----------|-----------|---------------------|------------------------------|--|-----------------|-------------------------------|
| | | Measuring range, mm | Measuring force, nominal*, N | Measuring bolt retraction | Sealing bellows | Nominal/Maximal pressure, bar |
| 03230060 | GTL 212 | ± 1,5 | 1,2 | Pressure (bolt activation), spring (bolt retraction) | Viton | 0,7 / max 1,0 |
| 03230054 | GTL 222 | ± 1,5 | 1,2 | Pressure (bolt activation), spring (bolt retraction) | Viton | 0,7 / max 1,0 |
| 03230067 | GTL 212-A | ± 1,5 | 0,2 | Pressure (bolt activation), spring (bolt retraction) | Without bellows | 0,25 / max 6,0 |
| 03230063 | GT 222-A | ± 1,5 | 0,2 | Pressure (bolt activation), spring (bolt retraction) | Without bellows | 0,25 / max 6,0 |

| = | Table | Star | Star | Star | Star | Warning |
|---------------------------|--|-------------------|----------------|--------------|----------------|---------|
| Measuring bolt travel, mm | Max. permissible error for deviations in linearity, µm (L in mm) | Repeatability, µm | Hysteresis, µm | Cable output | Data Sheet No. | |
| GTL 212 | 0,2 + 2,4 · L ² (BPX: 0,2 + 0,8 · L) | 0,015 | 0,02 | Axial | 03200413 | |
| GTL 222 | 0,2 + 2,4 · L ² (BPX: 0,2 + 0,8 · L) | 0,015 | 0,02 | Radial | 03200393 | |
| GTL 212-A | 0,2 + 2,4 · L ² (BPX: 0,2 + 0,8 · L) | 0,015 | 0,02 | Axial | 03200430 | |
| GT 222-A | 0,2 + 2,4 · L ² (BPX: 0,2 + 0,8 · L) | 0,015 | 0,02 | Radial | 03200422 | |

* Electrical zero (N) ± 25 % deviation limit. Valid in vertical mounting position, measuring bolt lowered and in static measuring.

** For an amplitude of 10 % to the last value of the measuring range.



Pneumatic Probes ± 5 mm, 10,3 mm Bolt Travel, Long Travel

These probes are designed for use with measuring fixtures and machines with integrated automatic or semi-automatic measuring routines.

- Probes with long measuring travel and low resolution of values 8 mm dia. fixing shank.
- Suitable for multi-gauging inspection fixtures.
- Protection level IP65 ou IP50 as per IEC 60529.
- Wide range of accessories including measuring inserts, etc.
- LVDT probes compatible with measuring equipment from other suppliers available on request.



DIN 32876 Part 1

See table

Nickel-plated housing. Stainless steel measuring bolt, hardened. Viton sealing bellows = highly resistant fluoroelastomer

Fixing shank Ø 8 mm. Measuring bolt guided on ball-bearing. Distance from electrical zero of both stops is either adjustable (downward) or depending on the position of the lower stop (upward). Interchangeable inserts. M2,5 thread. Carbide ball tip Ø 3 mm. 2 m long cable. 5-pin DIN 45322 connector.

Supply frequency: 13 kHz (± 5 %) Max. mechanical frequency** 60 Hz.

0,09 µm/°C

20 ± 0,5°C

-10°C to 65°C

80 %

Protection level: IP65 (IEC 60529),

Mobile weight: 8 g

Transport packaging

Identification number

Inspection report with a declaration of conformity

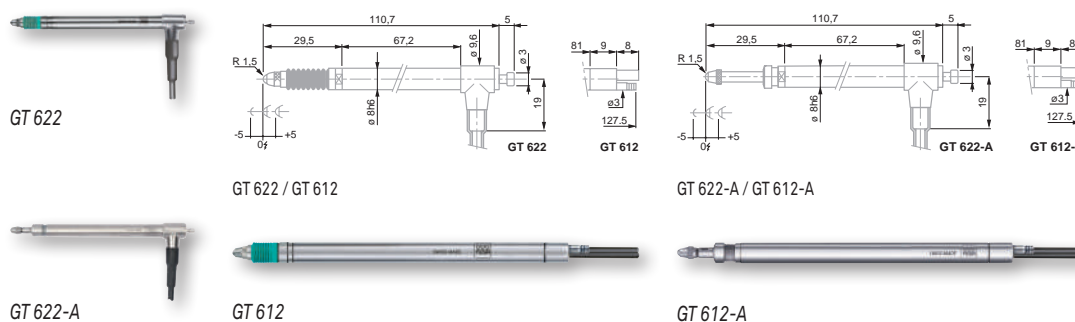

| No | = | Measuring range, mm | Measuring force, nominal*, N | Bolt retraction | Sealing bellows | Nominal/Maximal pressure, bar |
|----------|----------|---------------------|------------------------------|--|-----------------|-------------------------------|
| 03230062 | GT 612 | ± 5 | 2,0 | Pressure (bolt activation), spring (bolt retraction) | Viton | 1,1 / max 1,5 |
| 03230055 | GT 622 | ± 5 | 2,0 | Pressure (bolt activation), spring (bolt retraction) | Viton | 1,1 / max 1,5 |
| 03230070 | GT 612-A | ± 5 | 1,0 | Pressure (bolt activation), spring (bolt retraction) | Without bellows | 1,0 / max 6,0 |
| 03230071 | GT 622-A | ± 5 | 1,0 | Pressure (bolt activation), spring (bolt retraction) | Without bellows | 1,0 / max 6,0 |

| = | Measuring bolt travel, mm | Max. permissible error for deviations in linearity, µm (L in mm) | Repeatability, µm | Hysteresis, µm | Cable output | Data sheet No. |
|----------|---------------------------|--|-------------------|----------------|--------------|----------------|
| GT 612 | 10,3 | 1 + 4 · L (BPX: 0,6 + 0,8 · L) | 0,05 | 0,05 | Axial | 03200415 |
| GT 622 | 10,3 | 1 + 4 · L (BPX: 0,6 + 0,8 · L) | 0,05 | 0,05 | Radial | 03200394 |
| GT 612-A | 10,3 | 1 + 4 · L (BPX: 0,6 + 0,8 · L) | 0,05 | 0,05 | Axial | 03200433 |
| GT 622-A | 10,3 | 1 + 4 · L (BPX: 0,6 + 0,8 · L) | 0,05 | 0,05 | Radial | 03200434 |

* Electrical zero (N) ± 25 % deviation limit. Valid in vertical mounting position, measuring bolt lowered and in static measuring.
 ** For an amplitude of 10 % to the last value of the measuring range.



Wireless Probe ± 2 mm

Probes developed for devices requiring a greater freedom of movement during the measurement or for parts with large dimensions.

Bidirectional and wireless communication synchronized with the TWIN-STATION Receiver.

- Resolution 0,1 μ m.
- Range of 8 m, depending on environment.
- TESA wireless communication protocol independent of WiFi or Bluetooth.
- Autonomy 40 hours (rechargeable battery).
- Mounting stem \varnothing 8 mm with clamping possible over entire length.
- Measuring bolt mounted on ball bearing.
- Ball bearing guide separated from mounting stem in order not to negatively influence the movement of the measuring bolt in the event of improper clamping of the probe body.
- Level of protection IP54 according to IEC 60529.
- Wide range of measurement inserts.
- Swiss made.
- The TWIN-STATION (part number 05030012) manages and synchronizes up to 8 wireless probes.
- Interface Software TIS included in delivery content of the TWIN-STATION (part number 05030012): display of measured values, possibility to indicate tolerances, simple functions +A, -A, +A+B, +A-B, and export of values as a .csv file.

Note: The sale is limited to EU countries, Switzerland, USA, Canada and China.



GTL 21 W

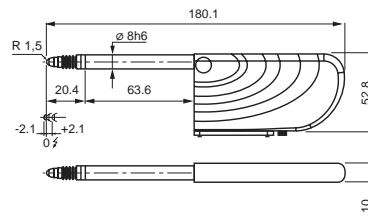

GTL 21 W

| | | | | | |
|---------------------|--|---------------------|-----------------------------|-----------------|-----------------|
| | | | | | |
| | | Measuring range, mm | Nominal measuring force*, N | Bolt retraction | Sealing bellows |
| 03230500 | GTL 21 W | ± 2 | 0,63 | Mechanical | Viton |
| OPTIONAL ACCESSORY: | | | | | |
| 05030012 | TWIN Station Interface for wireless probes | | | | |

| | | | | | | | |
|----------|-------------------------|--|------------------------|---------------------|--|---------------|----------------|
| | | | | | | | |
| | Max. plunger travel, mm | Maximum permissible error, μ m (L in mm) | Repeatability, μ m | Hysteresis, μ m | Setting of lower stop of the measuring bolt***, mm | Cable output | Data sheet No. |
| GTL 21 W | 4,3 | 0,4 + 0,8 · L | 0,10 | 0,5 | Fixed stops: lower -2,1 upper +2,1 | Without cable | 03200602 |

* Electrical zero (N) ± 25 % deviation limit. Valid in vertical mounting position, measuring bolt lowered and in static measuring.
 ** For an amplitude of 10 % to the last value of the measuring range.
 *** Distance from electrical zero.

- DIN 32876 Part 1
- See table
- Nickel-plated housing
Stainless steel measuring bolt, hardened
Viton sealing bellows = highly resistant fluoroe-lastomer
- Fixing body nickel \varnothing 8 mm
Stainless steel measuring bolt, hardened and ball bearing guided
Fixed upper and lower stops
Interchangeable inserts
M2,5 thread
Carbide ball \varnothing 3 mm
Mini jack connector for charger.
- Mechanical max. frequency**: 60 Hz
Power supply: 100 \div 240 VAC, 50 \div 60 Hz; 240 mAh
Rechargeable battery: 3,7 V, min. 550 mAh or 800 mAh
Frequency band: 2,4 GHz Range: 8 m, depending on environment.
- $\pm 0,2$ μ m/ $^{\circ}$ C
- $20 \pm 0,5$ $^{\circ}$ C
- 10° C to 40° C
- 80 %
- Protection level IP54 (IEC 60529)
- GTL 21 W: 6g
- Transport packaging
- Identification number
- Inspection report with a declaration of conformity



Wireless Probe ± 5 mm, Large Measuring Range

Probes developed for devices requiring a greater freedom of movement during the measurement or for parts with large dimensions.

Bidirectional and wireless communication synchronized with the TWIN-STATION Receiver.

- Resolution 0,1 µm.
- Range of 8 m, depending on environment.
- TESA wireless communication protocol independent from WiFi or Bluetooth.
- Autonomy 40 hours (rechargeable battery).
- Mounting body Ø 8 mm with possibility of clamping over entire length.
- Measuring bolt mounted on ball bearing.
- Separate guide bearing on the mounting body in order not to negatively influence the movement of the measuring bolt in the event of improper clamping on the probe body.
- Level of protection IP54 according to IEC 60529.
- Wide range of measurement probes.
- Swiss made.
- The TWIN-STATION (part number 05030012) manages and synchronizes up to 8 wireless probes.
- Interface Software TIS included in supply content of the TWIN-STATION (part number 05030012): display of measured values, possibility to indicate tolerances, simple functions +A, -A, +A+B, +A-B, and export of values in a .csv file.

Note: The sale is limited to EU countries, Switzerland, USA, Canada and China.



DIN 32876 Part 1

See table

Nickel-plated housing
Stainless steel measuring bolt, hardened. Viton = highly resistant fluoroelelastomer

Fixing shank Ø 8 mm. Measuring bolt guided on ball-bearing. Distance from electrical zero of both stops is either adjustable (downward) or depending on the position of the lower stop (upward). Interchangeable inserts. M2,5 thread. Carbide ball tip Ø 3 mm. Connector Mini-jack for charger.

Mechanical max. frequency**: 60 Hz
Power supply: 100 ÷ 240 VAC, 50 ÷ 60 Hz; 240 mAh
Rechargeable battery: 3,7 V, min. 550 mAh or 800 mAh
Frequency band: 2,4 GHz
Range: 8 m, depending on environment.

± 0,2 µm/°C

20 ± 0,5°C

10°C to 40°C

80 %

Protection operating envelope IP54 (IEC 60529)

GT 61 W: 8 g

Transport packaging

Identification number

Inspection report with a declaration of conformity



GT 61 W

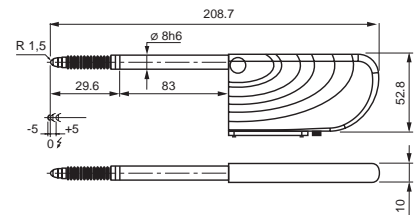

GT 61 W

| No | = | Measuring range, mm | Nominal measuring force*, N | Bolt retraction | Sealing bellows |
|----------------------------|--|---------------------|-----------------------------|-----------------|-----------------|
| 03230502 | GT 61 W | ± 5 | 0,9 | Mechanical | Viton |
| OPTIONAL ACCESSORY: | | | | | |
| 05030012 | TWIN Station Interface for wireless probes | | | | |

| | = | Max. bolt travel, mm | Maximum permissible error, µm (L in mm) | Repeatability, µm | Hysteresis, µm | Setting of lower stop of measuring bolt***, mm | Cable output | Data sheet No. |
|---------|---|----------------------|---|-------------------|----------------|--|---------------|----------------|
| GT 61 W | | 10,3 | 0,8 + 0,8- L | 0,24 | 0,5 | Fixed stops lower -5 upper +5 | Without cable | 03200621 |

* Electrical zero (N) ± 25 % deviation limit. Valid in vertical mounting position, measuring bolt lowered and in static measuring.

** For an amplitude of 10 % to the last value of the measuring range.

*** Distance from electrical zero.



Wireless Pneumatic Probe ± 1,5 mm

Probes developed for devices requiring a greater freedom of movement during the measurement or for parts with large dimensions.

Bidirectional and wireless communication synchronized with the TWIN-STATION Receiver.

- Resolution 0,1 µm.
- Range of 8 m, depending on environment.
- TESA wireless communication protocol independent from WiFi or Bluetooth
- Autonomy 40 hours (rechargeable battery).
- Support structure Ø 8 mm with enhanced clamping over its entire length
- Measuring rod mounted on ball bearing.
- Separate guide bearing on the holding body in order not to negatively influence the movement of the measuring rod in the event of improper clamping of the probe beads.
- Level of protection IP54 according to IEC 60529.
- Wide range of measurement probes.
- Swiss made.
- The TWIN-STATION (part number 05030012) manages and synchronizes up to 8 wireless probes.
- Interface Software TIS included in delivery content of the TWIN-STATION (art. 05030012): display of measured values, possibility to indicate tolerances, simple functions +A, -A, +A+B, +A-B, and export of values in a .csv file.

Note: The sale is limited to EU countries, Switzerland, USA, Canada and China.



GTL 212 W

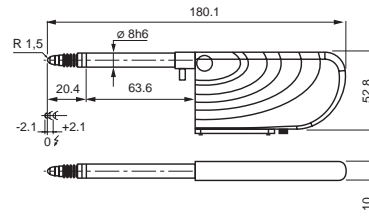

GTL 212 W

| No | = | Measuring range, mm | Nominal measuring force*, N | Bolt retraction | Sealing bellows | Nominal/maximal pressure, bar |
|----------|---------|---------------------|-----------------------------|--|-----------------|-------------------------------|
| 03230501 | GTL 212 | ± 1,5 | 1,2 | Pressure (bolt activation), spring (bolt retraction) | Viton | 0,7 / max. 1,0 |

OPTIONAL ACCESSORY:

05030012 TWIN Station Interface for wireless probes

| = | Max. measuring bolt travel, mm | Maximum permissible error, µm (L in mm) | Repeatability, µm | Hysteresis, µm | Setting of lower stop of the measuring bolt***, mm | Cable output | Data sheet No. |
|-----------|--------------------------------|---|-------------------|----------------|--|---------------|----------------|
| GTL 212 W | 4,3 | 0,4 + 0,8 · L | 0,10 | 0,5 | Fixed stops: lower -2,1 upper +2,1 | Without cable | 03200620 |

* Electrical zero (N) ± 25 % deviation limit. Valid in vertical mounting position, measuring bolt lowered and in static measuring.

** For an amplitude of 10 % to the last value of the measuring range.

*** Distance from electrical zero.

- DIN 32876 Part 1
- See table
- Nickel-plated housing
Stainless steel measuring bolt, hardened
Viton sealing bellows = highly resistance fluororelastomer
- Fixing body nickel Ø 8 mm
Stainless steel measuring bolt, hardened and ball bearing guided
Fixed upper and lower stops
Probe interchangeable
M2,5 thread
Carbide ball Ø 3 mm
Mini jack connector for charger.
- Mechanical max. frequency**: 60 Hz
Power supply: 100 ÷ 240 VAC, 50 ÷ 60 Hz; 240 mAh
Rechargeable battery: 3,7 V, min. 550 mAh or 800 mAh
Frequency band: 2,4 GHz
Range: 8 m, depending on environment.
- ± 0,2 µm/°C
- 20 ± 0,5°C
- 10°C to 40°C
- 80 %
- Protection IP54 (IEC 60529)
- GTL 212 W: 6g
- Transport packaging
- Identification number
- Inspection report with a declaration of conformity



Wireless Pneumatic Probe ± 5 mm, Large Measuring Range

Probes developed for devices requiring a greater freedom of movement during the measurement or for pieces with large dimensions.

Bidirectional and wireless communication synchronized with the TWIN-STATION Receiver.

- Resolution 0,1 µm.
- Range of 8 m, depending on environment.
- TESA wireless communication protocol independent from WiFi or Bluetooth.
- Autonomy 40 hours (rechargeable battery).
- Mounting body Ø 8 mm with enhanced clamping over its entire length.
- Measuring bolt mounted on ball bearing.
- Separate guide bearing on the holding body in order not to negatively influence the movement of the measuring bolt in the event of improper clamping on the probe body.
- Level of protection IP54 according to IEC 60529.
- Wide range of measurement probes.
- Swiss made.
- The TWIN-STATION (part number 05030012) manages and synchronizes up to 8 wireless probes.
- Interface Software TIS included in delivery content of the TWIN-STATION (art. 05030012): display of measured values, possibility to indicate tolerances, simple functions +A, -A, +A+B, +A-B, and export of values in a .csv file.

Note: The sale is limited to EU countries, Switzerland, USA, Canada and China.



GT 612 W

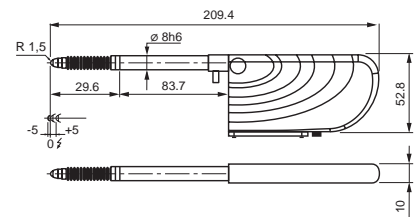

GT 612 W

- DIN 32876 Part 1
- See table
- Nickel-plated housing
Stainless steel measuring bolt, hardened
Viton sealing bellows = highly resistance fluoroe-lastomer
- Fixing body nickel Ø 8 mm
Stainless steel measuring bolt, hardened and ball bearing guided
Fixed upper and lower stops
Probe interchangeable
M2, 5 thread
Carbide ball Ø 3 mm
Mini jack connector for charger
- Mechanical max. frequency**: 60 Hz
Power supply: 100 ÷ 240 VAC, 50 ÷ 60 Hz; 240 mAh
Rechargeable battery: 3,7 V, min. 550 mAh or 800 mAh
Frequency band: 2,4 GHz
Range: 8 m, depending on environment.
- Wireless transmission, TWIN-STATION Receiver (05030012)
- ± 0,2 µm/°C
- 20 ± 0,5°C
- 10°C to 40°C
- 80 %
- Protection level IP54 (IEC 60529)
- GT 612 W: 8 g
- Transport packaging
- Identification number
- Inspection report with a declaration of conformity

| No | GT 612 W | Measuring range, mm | Nominal measuring force*, N | Bolt retraction | Sealing bellows | Nominal/maximal pressure, bar |
|----------|----------|---------------------|-----------------------------|--|-----------------|-------------------------------|
| 03230503 | GT 612 W | ± 5 | 2,0 | Pressure (bolt activation), spring (bolt retraction) | Viton | 1,1 / max. 1,5 |

OPTIONAL ACCESSORY:

05030012 TWIN Station Interface for wireless probes

| Max. bolt travel, mm | Maximum permissible error, µm (L in mm) | Repeatability, µm | Hysteresis, µm | Setting of lower stop of measuring bolt***, mm | Cable output | Data sheet No. | |
|----------------------|---|-------------------|----------------|--|---------------|----------------|--|
| GT 612 W 10,3 | 0,8 + 0,8 · L | 0,24 | 0,5 | Fixed stops: lower -5 upper +5 | Without cable | 03200622 | |

* Electrical zero (N) ± 25 % deviation limit. Valid in vertical mounting position, measuring bolt lowered and in static measuring.

** For an amplitude of 10 % to the last value of the measuring range.

*** Distance from electrical zero.



USB Probes ± 2 mm, 4,3 mm Range

Universal probes for applications aided by a USB connection.

- Probe mounting body Ø 8 mm with enhanced clamping over its entire length.
- Measuring bolt mounted on ball bearing.
- Separate guide bearing on the mounting body in order not to negatively influence the movement of the measuring bolt in the event of improper clamping of the probe beads.
- Level of protection IP65 according to IEC 60529.
- Wide range of measurement inserts.
- TSIP software interface included in supply 1 to 4 USB probes display.
- Possibility of indicating tolerances and simple functions + A, -A, + A + B + AB.
- To manage more than 4 probes USB, use the DataDirect (part number 04981001) or StatExpress software (part number 04981002), available as an option.



TSIP Software



GTL 21 USB

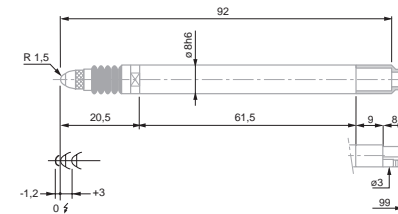

GTL 21 USB



GTL 22 USB

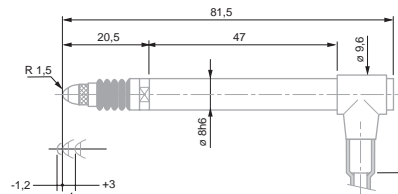

GTL 22 USB

| No | = | Measuring range, mm | Nominal measuring force*, N | Bolt retraction | Sealing bellows |
|----------|------------|---------------------|-----------------------------|-------------------|-----------------|
| 03230200 | GTL21 USB | ± 2 | 0,63 | Mechanical | Viton |
| 03230201 | GTL 22 USB | ± 2 | 0,63 | Mechanical/vacuum | Viton |

| = | Measuring bolt travel, mm | Max. permissible error, µm (L in mm) | Repeatability, µm | Hysteresis, µm | Setting of lower stop of measuring bolt*** mm | Cable output | Data sheet No. |
|------------|---------------------------|--------------------------------------|-------------------|----------------|---|--------------|----------------|
| GTL21 USB | 4,3 | 0,4 + 0,8 · L | 0,1 | 0,5 | Fixed stops: lower -2,0 upper +2,0 | Axial | 03200587 |
| GTL 22 USB | 4,3 | 0,4 + 0,8 · L | 0,1 | 0,5 | Fixed stops: lower -2,0 upper +2,0 | Radial | 03200588 |

* Electrical zero (N) ± 25 % deviation limit. Valid in vertical mounting position, measuring bolt lowered and in static measuring.

** For an amplitude of 10 % to the last value of the measuring range.

*** Distance from electrical zero.



DIN 32876 Part 1



See table



Nickel-plated housing, Stainless steel measuring bolt, hardened. Viton sealing bellows = highly resistant fluoroelelastomer



Fixing body Ø 8 mm. Measuring bolt guided on ball bearing. Fixed upper and lower stops. Interchangeable inserts. M 2,5 thread. Carbide ball Ø 3 mm. Cable length: 2,9 m. USB Type A plug connector



Max. mechanical frequency** 60 Hz.
Consumption: 70 mAh, 5V
Normal measuring interval = 80ms (optimal accuracy)
Minimal measuring interval = 20ms (most rapid transfer of data)
Stabilisation time after switching power on = 12 min.



0,2 µm/°C



20 ± 0,5°C



10°C to 40°C



80 %



IP65 (IEC 60529)



Mobile weight: 6 g



Transport packaging



Identification number



Inspection report with a declaration of conformity



USB Pneumatic Probes ± 1,5 mm, 3,1 mm Bolt Travel

Universal probes for applications facilitated by a USB connection

- Mounting body Ø 8 mm with possibility of clamping over its entire length.
- Measuring rod mounted on ball bearing.
- Separate guide bearing on the holding body in order not to negatively influence the movement of the measuring bolt in the event of improper clamping of the probe beads.
- Level of protection IP65 or IP50 according to IEC 60529.
- Wide range of measurement inserts.
- TSIP software interface included in supply: display 1 to 4 USB probes. Possibility of indicating tolerances and simple functions + A, -A, + A + B + AB.
- To manage more than 4 probes USB, use the DataDirect (part number 04981001) or StatExpress software (part number 04981002), available as an option.



DIN 32876 Part 1



See table



Nickel-plated housing. Stainless steel measuring bolt, hardened. Viton sealing bellows = highly resistant fluoroe elastomer



Fixing shank Ø 8 mm. Measuring bolt on ball bearing guide. Fixed lower and upper stops. Interchangeable measuring insert. Thread M2,5. Carbide ball Ø 3 mm Cable length: 2,9 m USB type A connector



Max. mechanical frequency** 60 Hz.
Consumption: 70 mAh, 5V
Normal measuring interval = 80 ms (optimal accuracy)
Minimal measuring interval = 20 ms (most rapid transfer of data)
Stabilisation time after switching power on = 12 min.
Remark: Compressed air supply must be generated through a filter and precision regulator. The air should have a humidity of < 60 % and be filtered to < 0,5 µm.



0,2 µm/°C



20 ± 0,5°C



10°C to 40°C



80 %



IP65 (IEC 60529) or IP50 for GTL 222-A



Mobile weight: 6 g



Transport packaging



Identification number



Inspection report with a declaration of conformity



GTL 222 USB

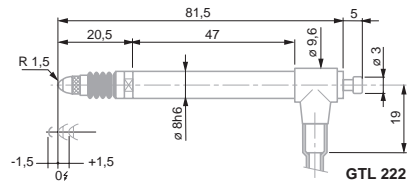

GTL 222 USB



TSIP Software

| No | = | Table | Hand | Gear | Gear | Gear |
|----------|------------|---------------------|-----------------------------|--|-----------------|-------------------------------|
| 03230202 | GTL222 USB | Measuring range, mm | Nominal measuring force*, N | Bolt retraction | Sealing bellows | Nominal/Maximal Pressure, bar |
| | | ± 1,5 | 1,2 | Pressure (bolt activation), spring (bolt retraction) | Viton | 0,7 / max 1,0 |

| = | Table | Hand | Hand | Hand | Gear | Warning |
|------------|---------------------------|--------------------------------------|-------------------|----------------|--------------|----------------|
| GTL222 USB | Measuring bolt travel, mm | Max. permissible error, µm (L in mm) | Repeatability, µm | Hysteresis, µm | Cable output | Data sheet No. |
| | 3,1 | 0,4 + 0,8 · L | 0,1 | 0,5 | Radial | 03200589 |

* Electrical zero (N) ± 25 % deviation limit. Valid in vertical mounting position, measuring bolt lowered and in static measuring.

** For an amplitude of 10 % to the last value of the measuring range.



USB Probes ± 5 mm, 10,3 mm Bolt Travel, Extended Measuring Range

USB universal probes for applications facilitated by a USB connection.

- Probes designed for long measuring travel and low resolution measurement values.
- Probe mounting body Ø 8 mm with possibility of clamping over its entire length.
- Measuring bolt mounted on ball bearing.
- Separate guide bearing on the holding body in order not to negatively influence the movement of the measuring bolt in the event of improper clamping of the probe beads.
- Level of protection IP65 according to IEC 60529.
- Wide range of measurement inserts.
- TSIP software interface included in supply 1 to 4 USB probes display. Possibility of indicating tolerances, simple functions + A, -A, + A + B + AB.
- To manage more than 4 USB probes, use the DataDirect (part number 04981001) or StatExpress software (part number 04981002), available as an option.



GT 61 USB

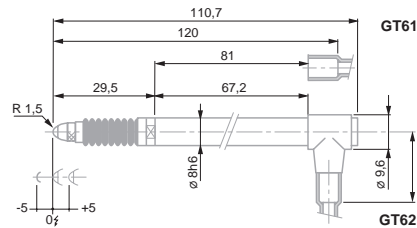

GT 61 USB / GT 62 USB



TSIP Software

| No | = | Measuring range, mm | Nominal measuring force*, N | Bolt retraction | Sealing bellows |
|----------|----------|---------------------|-----------------------------|-------------------|-----------------|
| 03230204 | GT61 USB | ± 5 | 0,90 | Mechanical | Viton |
| 03230205 | GT62 USB | ± 5 | 0,90 | Mechanical/vacuum | Viton |

| = | Measuring bolt travel, mm | Max. permissible error, µm (L in mm) | Repeatability, µm | Hysteresis, µm | Settings of lower stop of bolt***, mm | Cable output | Data sheet No. |
|----------|---------------------------|--------------------------------------|-------------------|----------------|---------------------------------------|--------------|----------------|
| GT61 USB | 10,3 | 0,8 + 0,8 · L | 0,24 | 0,5 | Fixed stops: lower -5,0 upper +5,0 | Axial | 03200591 |
| GT62 USB | 10,3 | 0,8 + 0,8 · L | 0,24 | 0,5 | Fixed stops: lower -5,0 upper +5,0 | Radial | 03200592 |

* Electrical zero (N) ± 25 % deviation limit. Valid in vertical mounting position, measuring bolt lowered and in static measuring.

** For an amplitude of 10 % to the last value of the measuring range.

*** Distance from electrical zero.



DIN 32876 Part 1



See table



Nickel-plated housing, Stainless steel measuring bolt, hardened. Viton sealing bellows = highly resistant fluor elastomer



Fixing shank Ø 8 mm. Measuring bolt guided on ball-bearing. Distance from electrical zero of both stops is either adjustable (downward) or depending on the position of the lower stop (upward). Interchangeable inserts. M2,5 thread. Carbide ball tip Ø 3 mm. Cable length 2,9 m. USB type A connector. 5-pin DIN 45322 connector.



Max. mechanical frequency 60 Hz
Power consumption: 70 mAh
Normal measurement interval = 80ms (maximum accuracy)
Minimum measurement interval = 20ms (fastest transfer data).
Stabilisation time after power on = 12 min



0,09 µm/°C



20 ± 0,5°C



10°C to +40°C



80 %



IP65 (IEC 60529)



Mobile weight: 8 g



Transport packaging



Identification number



Inspection report with a declaration of conformity





DIN 32876 Part 1



See table



See standard probes technical data



Cable length: 2 m. DIN 45322 plug connector, 5 poles. Use to connect to a device with an analogue input. For more information, refer to technical data for standard probes



Supply voltage: ± 15 V
Consumption: 15 mA
Adjustable load: > 1 k Ω . Can be used in any position.
Special versions on request: Sensitivity: 2 V/mm, 5 V/mm, 10 V/mm output: 0 V to +10 V (max +10 V)



See standard probes technical data



See standard probes technical data



See standard probes technical data



80 %



See standard probes technical data



See standard probes technical data



Transport packaging



Identification number



See standard probes technical data

DC Probes ± 2 mm (Output Signal in V)

Probe provided with an electronic box which converts the signal to obtain an output DC voltage

Typically used for direct connection to a computer unit or interface equipped with an analogue input

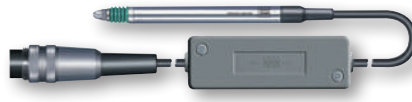

GTL 21 DC

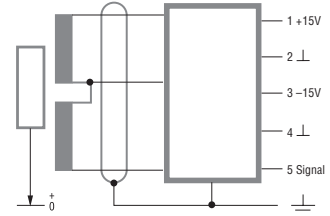

DIN 5 pin connection schematic

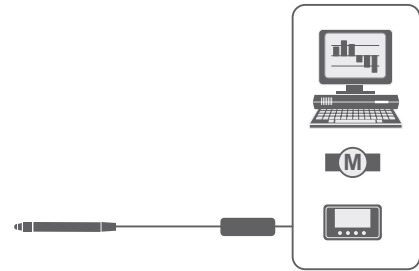

Connection of DC probe to a computer, an interface or a tracker

| | | | Measuring range, mm | Nominal measuring force*, N | Bolt retraction | Sealing bellows | Output voltage, V | Sensitivity, V/mm |
|----------|--|-----------|---------------------|-----------------------------|---------------------|-----------------|-------------------|-------------------|
| 03230059 | | GTL 21 DC | ± 2 | 0,63 | Mechanical | Viton | ± 2 | 1 |
| 03230058 | | GTL 22 DC | ± 2 | 0,63 | Mechanical / vacuum | Viton | ± 2 | 1 |

| | | Measuring bolt travel, mm | Max. permissible error for deviations in linearity, μ m (L in mm) | Repeatability, μ m | Data sheet No. |
|-----------|--|---------------------------|---|------------------------|----------------|
| GTL 21 DC | | 4,3 | $0,2 + 3,5 \cdot L^2$ | 0,1 | 03200396 |
| GTL 22 DC | | 4,3 | $0,2 + 3,5 \cdot L^2$ | 0,1 | 03200397 |

* Electrical zero (N) ± 25 % deviation limit. Valid in vertical mounting position, measuring bolt lowered and in static measuring.



DC Probes ± 5 mm (Output Signal in V), with Extended Measuring Range

Probe provided with an electronic box which converts the signal to obtain an output DC voltage

Typically used for direct connection to a computer unit or an interface equipped with an analogue input

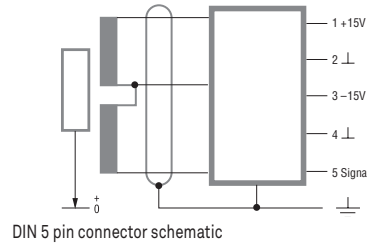
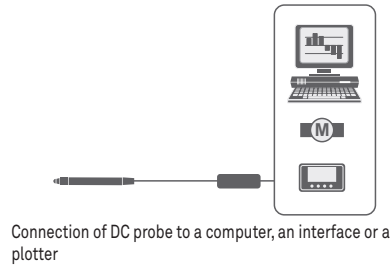

| No | = | Measuring range, mm | Nominal measuring force*, N | Bolt retraction | Sealing bellows | Output voltage, V | Sensitivity, V/mm |
|----------|----------|---------------------|-----------------------------|---------------------|-----------------|-------------------|-------------------|
| 03230086 | GT 61 DC | ± 5 | 0,9 | Mechanical | Viton | ± 5 | 1 |
| 03230087 | GT 62 DC | ± 5 | 0,9 | Mechanical / vacuum | Viton | ± 5 | 1 |

| = | Measuring bolt travel, mm | Max. permissible error for deviations in linearity, µm (L in mm) | Repeatability, µm | Data sheet No. |
|----------|---------------------------|--|-------------------|----------------|
| GT 61 DC | 10,3 | 1 + 4 · L | 0,1 | 03200519 |
| GT 62 DC | 10,3 | 1 + 4 · L | 0,1 | 03200520 |

* Electrical zero (N) ± 25 % deviation limit. Valid in vertical mounting position, measuring bolt lowered and in static measuring.



DIN 32876 Part 1



See table



See standard probes technical data



Cable length: 2 m. DIN 45322 plug connector, 5 poles. Use to connect to a device with an analogue input. For more information, refer to technical data on standard probes



Supply voltage: ± 15 V
Consumption: 15 mA
Adjustment load: > 1 kΩ
Can be used in any position. Special versions on request.
Sensitivity: 2 V/mm, 5 V/mm, 10 V/mm
Output: 0 V to +10 V (max +10 V).



See standard probes technical data



See standard probes technical data



See standard probes technical data



80 %



See standard probes technical data



See standard probes technical data



Transport packaging



Identification number



See standard probes technical data



DC Miniature Probes ± 1 mm (Output Signal in V)

Probe provided with an electronic box which converts the signal to obtain an output DC voltage

Typically used for direct connection to a computer unit or an interface equipped with an analogue input

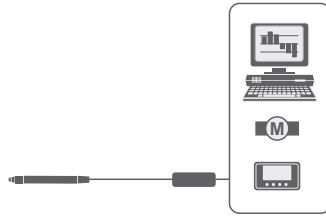

Connection of a DC probe to a computer, an interface or a plotter

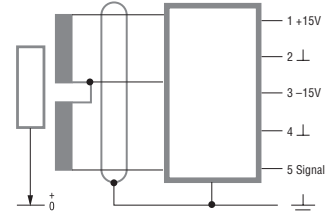

DIN 5 pin connection schematic

- See standard probes technical data
- DIN 32876 Part 1
- See table
- See standard probes technical data
- Cable length: 2 m. DIN 45322 plug connector, 5 poles. Use to connect to a device with an analog input. For more information, refer to technical data for standard probes
- Drive voltage: ± 15 V
Consumption: 15 mA
Adjustment load: > 1 kΩ. Can be used in any position. Special versions on request. Sensitivity: 2 V/mm, 5 V/mm, 10 V/mm Output: 0 V à +10 V (max +10 V)
- See standard probes technical data
- See standard probes technical data
- See standard probes technical data
- 80 %
- See standard probes technical data
- See standard probes technical data
- Transport packaging
- Identification number
- See standard probes technical data

| | | | | | | | |
|----------|----------|---------------------|-----------------------------|---------------------|-----------------|-------------------|-------------------|
| | | | | | | | |
| | | Measuring range, mm | Nominal measuring force*, N | Bolt retraction | Sealing bellows | Output voltage, V | Sensitivity, V/mm |
| 03230085 | GT 44 DC | ± 1 | 0,4 | Mechanical / vacuum | Viton | ± 1 | 1 |

| | | | | |
|----------|---------------------------|--|-------------------|----------------|
| | | | | |
| | Measuring bolt travel, mm | Max. permissible error for deviations in linearity, µm (L en mm) | Repeatability, µm | Data sheet No. |
| GT 44 DC | 2,1 | 0,2 + 5 · L ³ | 0,1 | 03200518 |

* Electrical zero (N) ± 25 % deviation limit. Valid in vertical mounting position, measuring bolt lowered and in static measuring.



Lever DC Probes ± 0,3 mm (Output Signal in V)

Probe provided with an electronic box which converts the signal to obtain an output DC voltage

Typically used for direct connection to a computer unit or an interface equipped with an analogue input

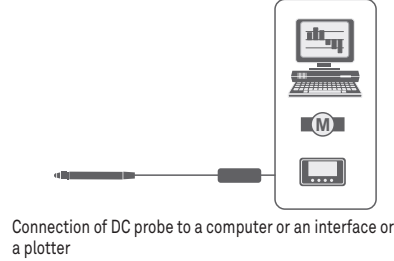
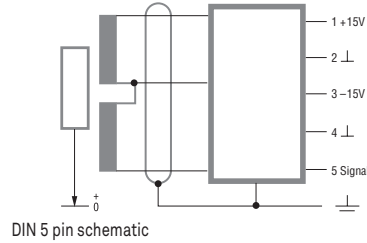

| No | = | Measuring range, mm | Nominal measuring force*, N | Bolt retraction | Sealing bellows | Output voltage, V | Sensitivity, V/mm |
|----------|---------|---------------------|-----------------------------|--------------------|-----------------|-------------------|-------------------|
| 03230081 | GT31 DC | ± 0,3 | 0,1 | Without retraction | Without bellows | ± 0,3 | 1 |

| = | Measuring bolt travel, mm | Max. permissible error for deviations in linearity, µm (L in mm) | Repeatability, µm | Data sheet No. |
|---------|---------------------------|--|-------------------|----------------|
| GT31 DC | 0,7 | 0,2 + 50 · L ² | 0,1 | 03200484 |

* Electrical zero (N) ± 25 % deviation limit. Valid in vertical mounting position, measuring bolt lowered and in static measuring.



DIN 32876 Part 1



See table



See standard probes technical data



Cable length: 2 m. DIN 45322 plug connector, 5 poles. Use to connect to a device with an analog input. For more information, refer technical data on standard probes



Drive voltage: ± 15 V
Consumption: 15 mA
Adjustment load: > 1 kΩ. Can be used in any measuring position. Special versions on request.
Sensitivity: 2 V/mm, 5 V/mm, 10 V/mm
Output: 0 V to +10 V (max +10 V)



See standard probes technical data



See standard probes technical data



See standard probes technical data



80 %



See standard probes technical data



See standard probes technical data



Transport packaging



Identification number



See standard probes technical data



GT 41 / GT 42 Miniature Probes, ± 0,3 mm, 0,7 mm Bolt Travel

Compact probes for use in small spaces – Designed to be mounted on a measuring head for the inspection of bores and similar features.



DIN 32876 Part 1



See table



Nickel-plated housing. Stainless steel measuring bolt, hardened. Sealing bellows: Nitrile = resistant elastomer. Viton = highly resistant fluoroelastomer.



Fixing shank Ø 8 mm. Ball-bearing measuring bolt. Both lower and upper stops are fixed. Interchangeable insert. M2,5 thread. Carbide ball tip Ø 3 mm. 2 m long cable. 5-pin DIN 45322 connector.



Supply frequency: 13 kHz (± 5 %) Max. mechanical frequency** 60 Hz.



0,1 µm/°C



20 ± 0,5°C



-10°C to 65°C



80 %



Level of protection: IP65 (IEC 60529)



Mobile weight: 2 g



Transport packaging



Identification number



Inspection report with a declaration of conformity



GT 41

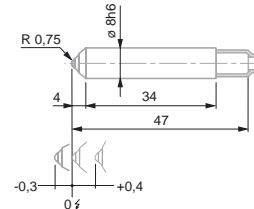

GT 41



GT 42

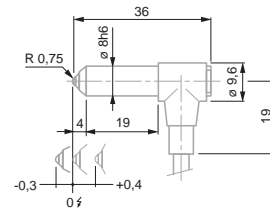

GT 42

| No | = | Measuring range, mm | Nominal measuring force*, N | Bolt retraction | Sealing bellows |
|----------|-------|---------------------|-----------------------------|-----------------|-----------------|
| 03230001 | GT 41 | ± 0,3 | 0,63 | None | Nitrile |
| 03230002 | GT 42 | ± 0,3 | 0,63 | Vacuum | Nitrile |

| | = | Measuring bolt travel, mm | Max. permissible error for deviations in linearity, µm (L en mm) | Repeatability, µm | Hysteresis, µm | Setting of lower stop of measuring bolt***, mm | Cable output | Data sheet No. |
|-------|-----|---------------------------|--|-------------------|------------------------------------|--|--------------|----------------|
| GT 41 | 0,7 | 0,2 + 5 · L ² | 0,01 | 0,01 | Fixed stops: lower -0,3 upper +0,4 | Axial | 03200258 | |
| GT 42 | 0,7 | 0,2 + 5 · L ² | 0,01 | 0,01 | Fixed stops: lower -0,3 upper +0,4 | Radial | 03200259 | |

* Electrical zero (N) ± 25 % deviation limit. Valid in vertical mounting position, measuring bolt lowered and in static measuring.

** For an amplitude of 10 % to the last value of the measuring range.

*** Distance from electrical zero.



GT 43 / GT 44 Miniature Probes, ± 1,0 mm , 2,1 mm Bolt Travel

Compact probes for use in small spaces – Designed to be mounted on a measuring head for the inspection of bores and similar features.



GT 43

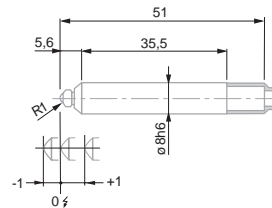

GT 43



GT 44

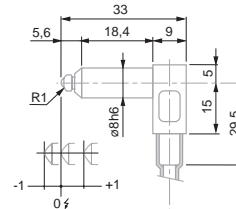

GT 44

| | | | Measuring range, mm | Nominal measuring force*, N | Bolt retraction | Sealing bellows |
|----------|-------|-----|---------------------|-----------------------------|-----------------|-----------------|
| 03230035 | GT 43 | ± 1 | 0,4 | Mechanical | Viton | |
| 03230017 | GT44 | ± 1 | 0,4 | Vacuum | Viton | |

| | Measuring bolt travel, mm | Max. permissible error for deviations in linearity, µm (L en mm) | Repeatability, µm | Hysteresis, µm | Setting of lower stop of bolt***, mm | Cable output | Data sheet No. | |
|-------|---------------------------|--|-------------------|----------------|--------------------------------------|--------------|----------------|--|
| GT 43 | 2,1 | 0,2 + 5 · L ² | 0,1 | 0,15 | Fixed stops: lower -1,05 upper +1,05 | Axial | 03200260 | |
| GT44 | 2,1 | 0,2 + 5 · L ² | 0,1 | 0,15 | Fixed stops: lower -1,05 upper +1,05 | Radial | 03200261 | |

* Electrical zero (N) ± 25 % deviation limit. Valid in vertical mounting position, measuring bolt lowered and in static measuring.

** For an amplitude of 10 % to the last value of the measuring range.

*** Distance from electrical zero.



DIN 32876 Part 1



See table



Nickel-plated housing, Stainless steel measuring bolt, hardened. Sealing bellows: Nitrile = resistant elastomer. Viton = highly resistant fluoroelastomer.



Fixing shank Ø 8 mm. Ball-bearing measuring bolt. Both lower and upper stops are fixed. Interchangeable insert. Carbide ball tip Ø 3 mm. 2 m long cable. 5-pin DIN 45322 connector.



Supply frequency: 13 kHz (± 5 %) Max. mechanical frequency**: 60 Hz.



0,1 µm/°C



20 ± 0,5°C



-10°C to 65°C



80 %



Level of protection: IP65 (IEC 60529)



Mobile weight: 2 g



Transport packaging



Identification number



Inspection report with a declaration of conformity



Probes, Unbranded Execution, Series 410 ± 1 mm, 2,5 mm Range, Short Body

Universal probes for common but constraining applications.

- 8 mm diameter probe body that can be clamped over its entire length.
- Ball bearing measuring bolt.
- Hardened steel body, hard-chrome plated.
- Degree of protection to IP62.
- Flexible axial cable exit fitted with a steel spring to prevent the cable from breaking.
- Other probes compatible with measuring equipment from other makers also available on request.

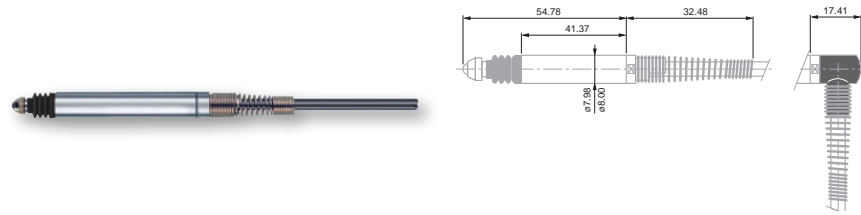

410

410 and accessory with radial cable exit (delivered with probe)

- DIN 32876 Part 1
- See in the table
- Nickel-plated housing. Stainless steel measuring bolt, hardened. Sealing bellows: Nitrile = resistant elastomer
- Fixing shank Ø 8 mm. Ball-bearing measuring bolt. Distance from electrical zero of both stops is either adjustable (downward) or depending on the position of the lower stop (upward). Interchangeable measuring insert with a 3 mm dia. tungsten carbide ball tip plus M2,5 thread. 2 m long cable. DIN 45322 5-pin connector.
- Supply frequency: 13 kHz (± 5 %) Max. mechanical frequency*: 60 Hz.
- 0,025 µm/°C
- 20 ± 0,5°C
- 10°C to +60°C
- IP65 (IEC 60529)
- Mobile weight: 3,1 g
- Shipping packaging
- Identification number

| 96410012 | 410 | Measuring range, mm | Nominal measuring force*, N | Bolt retraction | Sealing bellows |
|----------|-----|---------------------|-----------------------------|-----------------|-----------------|
| | | ± 1 | 0,60 | Mechanical | Nitrile |

| | Measuring bolt travel, mm | Max. permissible error for deviations in linearity, µm (L en mm) | Repeatability, µm | Setting of lower stop of the measuring bolt***, mm (factory setting) | Cable output | Data sheet No. |
|-----|---------------------------|--|-------------------|--|------------------|----------------|
| 410 | 2,5 | 0,2 % (for a measuring span of ± 1 mm) | 0,1 | Adjustable from -1,2 to 0 (factory setting -1,08) | Axial and radial | F96410012 |

* Electrical zero (N) ± 25 % deviation limit. Valid in vertical mounting position, measuring bolt lowered and in static measuring.

** For an amplitude of 10 % to the last value of the measuring range.

*** Distance from electrical zero.



Probes, Unbranded Execution, Series 160 ± 1 mm, 3,3 mm Bolt Travel, Short Body, Ø 6 mm

Compact size and robust construction makes these probes ideal for continuous use.

- Probe body Ø 6 mm.
- Clamping possible over entire length.
- Measuring bolt guided on ball bearing.
- Hard-chrome plated probe body, hardened steel.
- Protection level: IP62 as per IEC 60529.
- Executions compatible with measuring equipment from other suppliers available on request.

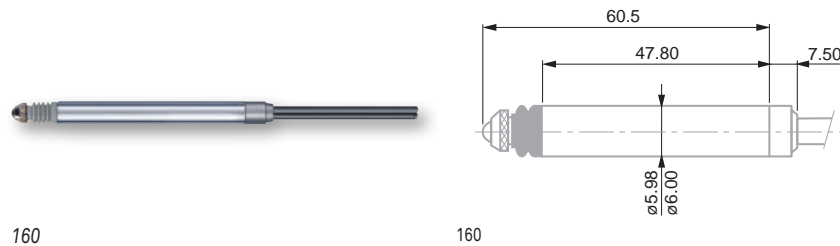

| | | | | | |
|----------|-----|---------------------|-----------------------------|-----------------|-----------------|
| | | | | | |
| | | Measuring range, mm | Nominal measuring force*, N | Bolt retraction | Sealing bellows |
| 96160013 | 160 | ± 1 | 0,60 | Mechanical | Viton |

| | | | | | | |
|---------------------------|---|--|--|---|----------------|-----------|
| | | | | | | |
| Measuring bolt travel, mm | Max. permissible error for deviation in linearity, µm (L in mm) | Repeatability, µm | Setting of lower stop of measuring bolt***, mm (factory setting) | Cable output | Data sheet No. | |
| 160 | 3,3 | 0,2 % (for a measuring span of ± 1 mm) | 0,1 | Adjustable from -1,2 to 0 (factory setting -1,08) | Axial | F96160013 |

* Electrical zero (N) ± 25 % deviation limit. Valid in vertical mounting position, measuring bolt lowered and in static measuring.

** For an amplitude of 10 % to the last value of the measuring range.

*** Distance from electrical zero.



DIN 32876 Part 1



See table



Nickel-plated housing. Stainless steel measuring bolt, hardened. Sealing bellows: Viton = highly resistant fluoroelelastomer.



Probe body Ø 6 mm. Measuring bolt guided on ball bearing. Distance between the lower stop and electrical zero adjustable. Interchangeable measuring insert. Thread M2. Carbide ball tip Ø 3 mm. 2 m long cable. DIN 45322 5-pin connector.



Supply frequency: 13 kHz (± 5 %) Max. mechanical frequency**: 60 Hz.



0,025 µm/°C



20 ± 0,5°C



0°C to 60°C



Protection level: IP62 (IEC 60529)



Mobile weight: 2,5 g



Transport packaging



Identification number



Probes, Unbranded Execution, Series 430 and 451, ± 0,5 mm, 1,25 et 2,10 mm Measuring Bolt Travel, Miniature

Their compact size and robust construction make them the ideal probes for a frequent use.

- Probe body Ø 8 mm.
- Clamping possible over its entire length.
- Measuring bolt on ball bearing guide.
- Hard chrome-plated probe body, hardened steel.
- Level of protection: IP62 as per IEC 60529.
- Probes compatible with measuring equipment from other suppliers also available on request.

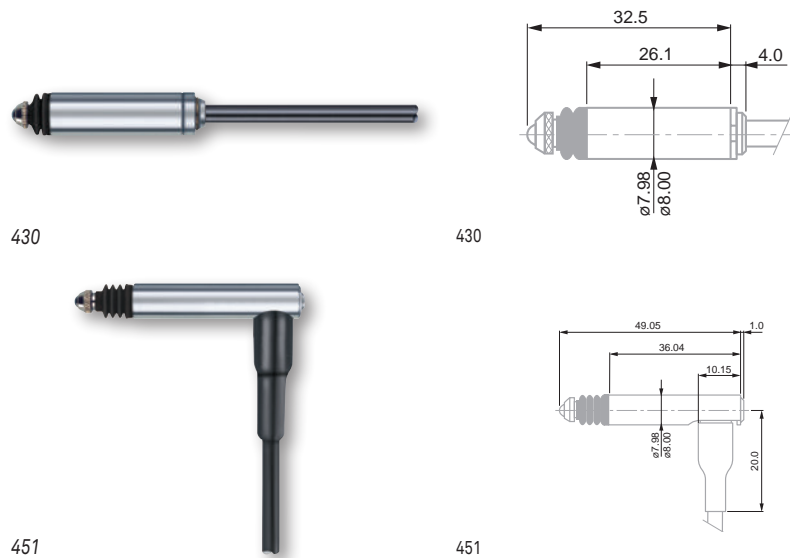

| | No | = | Measuring range, mm | Nominal measuring force*, N | Bolt retraction | Sealing bellows |
|----------|-----|-------|---------------------|-----------------------------|-----------------|-----------------|
| 96430029 | 430 | ± 0,5 | 0,75 | Mechanical | Nitrile | |
| 96441041 | 451 | ± 0,5 | 0,60 | Mechanical | Nitrile | |

| | = | Measuring bolt travel, mm | Max. permissible error for deviations in linearity, µm (L in mm) | Repeatability, µm | Setting of lower stop of measuring bolt***, mm (factory setting) | Cable output | Data sheet Nb |
|-----|------|--|--|---|--|--------------|---------------|
| 430 | 1,25 | 0,2 % (for a measuring span of ± 0,5 mm) | 0,2 | Adjustable from -0,7 to 0 (factory setting -0,58) | Axial | F96430029 | |
| 451 | 2,10 | 0,2 % (for a measuring span of ± 0,5 mm) | 0,1 | Fixed stops (factory setting: -0,58) | Radial | F96441041 | |

* Electrical zero (N) ± 25 % deviation limit. Valid in vertical mounting position, measuring bolt lowered and in static measuring.

** For an amplitude of 10 % to the last value of the measuring range.

*** Distance from electrical zero.



DIN 32876 Part 1



See table



Nickel-plated housing. Stainless steel measuring bolt, hardened. Sealing bellows: Nitrile = resistant elastomer.



Probe body Ø 8 mm. Measuring bolt guided on ball bearing. Adjustable distance between lower bolt and electrical zero. Interchangeable measuring insert. Thread M2,5. Carbide ball tip Ø 3 mm. Cable length: 2 m DIN 45322 5-pin connector.



Supply frequency: 13 kHz (± 5 %) Max. mechanical frequency*: 60 Hz..



0,025 µm/°C



20 ± 0,5°C



0°C to 60°C



Level of protection: IP65 (IEC 60529)



Mobile weight: 1,9 g (Series 439)
Mobile weight: 3,0 g (Series 451)



Transport packaging



Identification number



GT31 Lever Probes ± 0,3 mm, 0,3 mm Measuring Travel, Inclinable Lever



GT 31 with lever in perpendicular position

Well suited for use where probes with axial movement measuring bolts are inconvenient for measurements.

- Inclinable lever for measuring in two directions.
- Balanced lever system on ball-bearing.
- Interchangeable measuring insert, with carbide ball tip, inclinable through to 180°.
- Automatic reversal of the probing direction while the indication remains unchanged.
- Protected against shocks by 2 safety clutches.
- One-piece housing provided with 2 dovetails.
- Level of protection: IP40 as per IEC 60529.

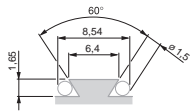

GT 31

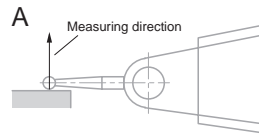

GT 31
Figure A - the leverage matches 1:1, no correction of the measured value needed

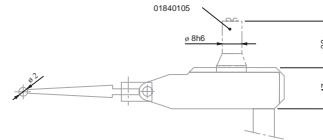

GT 31 side view and top view

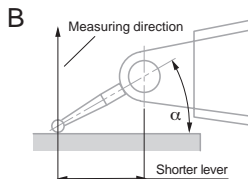

GT 31
Figure B - the leverage is no longer 1:1, correction of the measured value is needed.

Note
(Fig. A) With the insert lying parallel to the workpiece surface, the leverage matches 1:1. Therefore, no correction of the measured values is needed.
(Fig. B, angle α) Any other position will change the effective lever length, so that read values must be corrected. In this connection, please consult the instruction manual.

| | | | Measuring range, mm | Nominal measuring force*, N | Lever retraction | Sealing bellows |
|----------|-------|-------|---------------------|-----------------------------|------------------|-----------------|
| 03210802 | GT 31 | ± 0,3 | 0,1 | Without | Without bellows | Without bellows |
| 03210801 | GT 31 | ± 0,3 | 0,02 | Without | Without bellows | Without bellows |
| 03210803 | GT 31 | ± 0,3 | 0,1 | Without | Without bellows | Without bellows |

| | Measuring lever travel, mm | Max. permissible error for deviations in linearity, μm (L in mm) | Repeatability, μm | Hysteresis, μm | Setting of lower stop of the measuring insert***, mm | Cable output | Data sheet No. |
|-------|----------------------------|---|------------------------------|---------------------------|--|--------------|----------------|
| GT 31 | 0,7 | $0,2 + 50 \cdot L^2$ | 0,1 | 0,25 | Fixed lower and upper stops | Angled | 03200266 |

* Electrical zero (N) ± 25 % deviation limit. Valid in vertical mounting position, measuring bolt lowered and in static measuring.
 ** For an amplitude of 10 % to the last value of the measuring range.
 *** Distance from electrical zero.

- DIN 32876 Part 1
- ± 0,3 mm
- All-metal housing, matt-chromium finish
- 2 dovetail attachments for clamping. Both lower and upper stops are fixed. Stainless steel measuring stem. Interchangeable measuring inserts. Carbide ball tip Ø 2 mm. Cable length: 2 m. DIN 45322, 5 pin connector. Other measuring inserts available as optional accessories..
- Supply frequency: 13 kHz (± 5 %) Max. mechanical frequency**: 25 Hz.
- 20 ± 0,5°C
- 5°C to 60°C
- 80 %
- Protection level: IP40 (IEC 60529)
- Mobile weight: 12 g
- Transport packaging
- Identification number
- Declaration of conformity





DIN 32876 Part 1



See table



Hardened steel probe body, nickel-plated



Linear guidance on ball bearing, 4 M6 mounting threads. Fixed mechanical stops. Interchangeable inserts. Dovetail clamp for mounting holder. Cable length: 2 m. 5-pin connector DIN 45322.



Supply frequency: 13 kHz (± 5 %) Max. mechanical frequency**: 25 Hz.



-0,14 µm/°C



20 ± 0,5°C



-10°C to 65°C



80 %



IP50 (IEC 60529)



Mobile weight: 110 g



Transport packaging



Identification number



Inspection report with a declaration of conformity



Application: Minimal space usage with FMS units placed side by side



Application: small component measuring thanks to offset inserts

Probes with Parallel Guidance, ± 2 mm or ± 2,9 mm, 5,8 mm Measuring Travel

Modular construction enables the combination of elements, for example, such as springs, pneumatic cylinders and stops.

These universal probes are suited for multigauging fixtures as well as machines equipped with integrated inspection routines.

Versatility of applications:

- Probe can be used in any position for measuring.
- Measuring direction is adjustable.
- Retraction of the measuring insert is adjustable.
- Measuring force is adjustable depending on the accessory used.
- Possibility of using off-centre measuring inserts.

Unique design:

- Compact assembly noted for its robustness.
- Ball bearing guided movement.
- Wide variety of measuring inserts, holders and other accessories for measuring applications.
- LVDT execution versions compatible with melectronic equipment from other suppliers available on request.

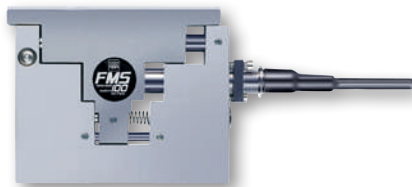

FMS 100



FMS 102

| No | = | Measuring range, mm | Nominal measuring force*, N | Bolt retraction | Sealing bellows |
|----------|---------|---------------------|-----------------------------|---------------------------------------|-----------------|
| 03230019 | FMS 100 | ± 2 | 2 | Retraction by air pressure (optional) | Without bellows |
| 03230049 | FMS 130 | ± 2,9 | 2 | Retraction by air pressure (optional) | Without bellows |
| 03230028 | FMS 102 | ± 2 | 2 | Retraction by air pressure (optional) | Without bellows |
| 03230050 | FMS 132 | ± 2,9 | 2 | Retraction by air pressure (optional) | Without bellows |

| = | Measuring bolt travel, mm | Max. permissible error for deviation in linearity, µm (L in mm) | Repeatability, µm | Hysteresis, µm | Setting of lower stop of measuring bolt***, mm | Cable output | Data sheet No. |
|---------|---------------------------|---|-------------------|----------------|--|--------------|----------------|
| FMS 100 | 5,8 | 0,2 + 3 · L ³ | 0,5 | 0,5 | Fixed stops: lower -2,9 upper +2,9 | Parallel | 03200253 |
| FMS 130 | 5,8 | 0,2 + 3 · L ³ | 0,5 | 0,5 | Fixed stops: lower -2,9 upper +2,9 | Parallel | 03200342 |
| FMS 102 | 5,8 | 0,2 + 3 · L ³ | 0,5 | 0,5 | Fixed stops: lower -2,9 upper +2,9 | Parallel | 03200254 |
| FMS 132 | 5,8 | 0,2 + 3 · L ³ | 0,5 | 0,5 | Fixed stops: lower -2,9 lower +2,9 | Parallel | 03200343 |

* Electrical zero (N) ± 25 % deviation limit. Valid in vertical mounting position, measuring bolt lowered and in static measuring.

** For an amplitude of 10 % to the last value of the measuring range.

*** Distance from electrical zero.



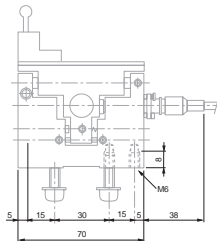

FMS 100

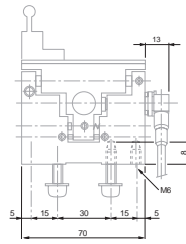

FMS 102

Configuration and Application of TESA FMS Probes

Shown below are the different possibilities for the activation and retraction of the probe insert during measurement cycles.

APPLICATION EXAMPLE A

- Activation of the probe insert in the direction of the part to be inspected using the measuring force produced by the spring set.
- Without retraction of the insert.

Result A
During the placing of a new part to be measured, the measuring insert remains in its contact position thanks to the measuring force produced by the spring set.

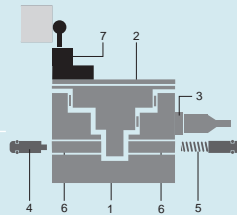

- 1 Static probe body
- 2 Mobile probe body
- 3 Measuring element with fine adjust
- 4 Adjustable stop
- 5 Spring set for producing measuring force
- 6 M6 mounting thread
- 7 Holder

APPLICATION EXAMPLE B

- Activation of the probe insert in the direction of the part to be measured using the measuring force of the spring set.
- Retraction of the insert by pneumatic pressure through a pneumatic connection.

Result B
During the placing of a new part to be measured, the measuring insert is retracted through activation of pressure via the pneumatic actuator.

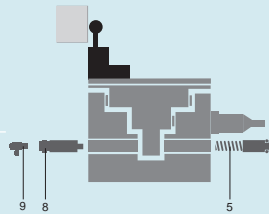

- 5 Spring set for producing measuring force
- 8 Pneumatic actuator (Part No. 03260440)
- 9 Connector (Part No. 024388)

APPLICATION EXAMPLE C

- Activation of the probe insert in the direction of the part to be inspected by pneumatic pressure and the measuring force of the spring set.
- Retraction of the insert by disabling the pneumatic pressure.

ATTENTION !
The force of the spring set (5) must be equal to that of the auxiliary spring element (10).

Result C
During the placing of a new part to be measured, the measuring insert is automatically retracted due to the disabling of the pneumatic pressure, which guarantees about security during the measuring cycle.

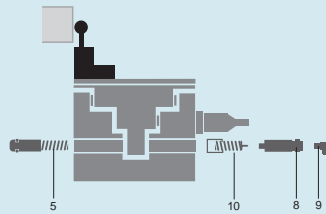

- 5 Spring set for producing measuring force
- 8 Pneumatic actuator (Part No. 03260440)
- 9 Connector (Part No. 024388)
- 10 Auxiliary spring element (Part No. 03260445)

This configuration is typically preferred when there is lack of space for connecting a pneumatic actuator (left side of example B).





DIN 32876 Part 1



See table



Hardened steel probe body, nickel-plated



Linear guidance on ball bearing, 4 M6 mounting threads.. Fixed mechanical stops.. Interchangeable inserts. Holder with dovetail clamping. Cable length: 2 m. 5-pin connector DIN 45322.



Supply frequency: 13 kHz (± 5 %). Max. mechanical frequency**: 25 Hz.



-0,14 µm/°C



20 ± 0,5°C



-10°C to 65°C



80 %



IP54 (IEC 60529)



Mobile weight: 110 g



Shipping packaging



Identification number



Inspection report with a declaration of conformity



Application: measurement with a protected FMS



FMS 102-P



FMS 100-P

Probes with Parallel Guidance, ± 2 mm or ± 2,9 mm, 5,8 mm Measuring Travel – Protected Version

- FMS 100-P, 102 -P, 130-P, 132-P provide dust protection of the 2 side faces.

Modular concept for combining elements, for example, such as springs, pneumatic actuators and stops.

These universal probes are suitable for mutigauging inspection fixtures as well as machines with integrated automated inspection routines.

Versatility of applications:

- Probe can be used in any position for measuring
- Measuring direction can be changed
- Retraction of the measuring insert is adjustable
- Measuring force is adjustable, depending on the accessory used
- Possibility of using off-centre measuring inserts

Unique design:

- Compact assembly noted for its robustness
- Ball bearing guided movement
- Wide variety of measuring inserts, holders and other accessories for measuring applications
- LVDT execution versions compatible with melectronic equipment from other suppliers available on request.

| No | = | Measuring range, mm | Nominal measuring force*, N | Bolt retraction | Sealing bellows |
|----------|----------|---------------------|-----------------------------|--|-----------------|
| 03230037 | FMS100-P | ± 2 | 2 | Retraction by air pressure (optional) | Without bellows |
| 03230051 | FMS130-P | ± 2,9 | 2 | Retraction by air pressure (optional) | Without bellows |
| 03230038 | FMS102-P | ± 2 | 2 | Retraction through air pressure (optional) | Without bellows |
| 03230052 | FMS132-P | ± 2,9 | 2 | Retraction through air pressure (optional) | Without bellows |

| | Measuring bolt travel, mm | Max. permissible errors for deviations in linearity, µm (L en mm) | Repeatability, µm | Hysteresis, µm | Setting of lower stop of measuring bolt***, mm | Cable output | Data sheet No. |
|----------|---------------------------|---|-------------------|----------------|--|--------------|----------------|
| FMS100-P | 5,8 | 0,2 + 3 · L ³ | 0,5 | 0,5 | Fixed stops: lower -2,9 upper +2,9 | Parallel | 03200283 |
| FMS130-P | 5,8 | 0,2 + 3 · L ³ | 0,5 | 0,5 | Fixed stops: lower -2,9 upper +2,9 | Parallel | 03200344 |
| FMS102-P | 5,8 | 0,2 + 3 · L ³ | 0,5 | 0,5 | Fixed stops: lower -2,9 upper +2,9 | Angled | 03200289 |
| FMS132-P | 5,8 | 0,2 + 3 · L ³ | 0,5 | 0,5 | Fixed stops: lower -2,9 upper +2,9 | Angled | 03200345 |

* Electrical zero (N) ± 25 % deviation limit. Valid in vertical mounting position, measuring bolt lowered and in static measuring.

** For an amplitude of 10 % to the last value of the measuring range.

*** Distance from electrical zero.



TESATRONIC TT10 Probe Display Unit

- Perfect for inspection on the surface plate, on an inspection work station in production or directly on a machine.
- Battery power supply.
- Can be used wherever the presence of a power cable can inhibit measuring operations.
- Frequently used with a GT 31 lever probe for setting operations.
- Simple-to-use function keys and easy reading of the combined digital/ analogue indication.
- Liquid crystal (LCD) indication display. No pointer which ensures an excellent repeatability and negligible hysteresis.
- 3 measuring ranges, switchable manually or automatically depending on the measured value.
- Metric/inch conversion.
- Signal amplification (5x) for easy display setting.
- Quick zero-setting with the help of a touch key thanks to digital technology.
- Signal input for one probe.
- Opto-coupled RS232 compatible digital output.



TT10

TT10 with template

- DIN 32876 Part 1
- Circular scale Ø 40 mm
- 3-decade display plus minus sign
- 9 x 4,5 mm
- 66 x 57 mm LCD display size
- Value limit for a temperature of 20°C and a relative humidity of ≤ 50 %: Analogue display: 2 % Digital display: 2 %
- ± 1 digital step
- 95 x 170 x 68 mm (W x D x H)
- Resistant plastic material
- For a temperature of 20°C and a relative humidity of ≤ 50 %: Analogue and digital response time: ≤ 100 ms. Holding of digital display: ≥ 100 ms.
- For a temperature of 20°C and a relative humidity of ≤ 50 %: Zero drift and signal amplification: ≤ 0,005 %/°C. Display frequency limit with respect to input signal: 10 Hz
- Opto-coupled RS232
- Supply: 3,5 V to 4,5 V, 3 batteries AA 1,5 V, type LRC 6. Power consumption: ≈ 7 mW/3,5 V Probe supply voltage: 0,7 V Supply frequency: 13 ± 0,65 kHz









| | | |
|---|-------------------------|-------------------------------|
| | | |
| | Number of probes inputs | Automatic conversion of range |
| TESATRONIC TT10 portable display unit for TESA inductive probes | 1 | • |

| | | | |
|----------|---|-------------------------|--------|
| | | | |
| | | Measuring range zoom x5 | Memory |
| 04430008 | TESATRONIC TT10 portable display unit for TESA inductive probes | • | - |





With a measuring support

-  0°C to 60°C
-  -10°C to 70°C
-  80 %, without condensation
-  Level of protection: IP42 (IEC 60529)
-  EN 500081-1
EN 500081-2
EN 500082-1
EN 500082-2
-  490 g (including batteries)
-  Transport packaging
-  Identification number
-  Declaration of conformity

STANDARD ACCESSORIES:

- | | |
|-----------------|---|
| 04768002 | 3 AA 1,5 V batteries, type LRC 6 for TT10 |
| 04460007 | 10x templates for TT10 |



With a measuring support

OPTIONAL ACCESSORIES:

- | | |
|-----------------|--|
| 04768000 | Hand switch for manually triggering data transfer. Jack plug connector, 1,8 m - TESA SPC PRINTER printer - TESATRONIC TT display units |
| 04768001 | Foot switch for triggering data transfer. Jack plug, 1,8 m - TESA SPC PRINTER printer - TESATRONIC (TT) display units |
| 04761023 | Cable: miniDIN 8p/m to Sub-D 9p/f, 2m for TT10 and MICRO-HITE manual versions 10/11/12 |
| 04761024 | Cable: miniDIN 8p/m to Sub-D 25p/m, 2m for TT10 and MICRO-HITE manual versions 10/11/12 |



- DIN 32876 Part 1
- 110 mm scale length
- 50 scale divisions
- 6-decade display plus minus sign
- 12,5 x 6,6 mm
- 126 x 62 mm LCD display
- Value limit for a temperature of 20°C and a relative humidity of ≤ 50 %
 TT20:
 Analogue display: 2%
 Digital display 0,3%
 Digital output: 0,3%
 TT60:
 Analog display: 2%
 Digital display: 0,3%
 Analogue output: 0,3%
 Digital output: 0,3%
- ± 1 numerical interval
- 255 x 235 x 120 mm (W x D x H)
- Resistant plastic material
- For a temperature of 20°C and a relative humidity of ≤ 50 %:
 TT20:
 Response time of analogue, digital and LED classification displays: ≤ 80 ms.
 Maintenance of digital display: 80 ms.
 TT60:
 Response time of analogue, digital and LED classification displays: ≤ 80 ms.
 Holding of digital display: 80 ms.
 Response time of the analogue output signal in relation to analogue display: ≤ 30 ms.

TESATRONIC TT20 and TT60 Probe Display Units

- Functional reliability.
- User-friendly.
- Essential for inspection in production or metrology laboratory.

TESATRONIC TT20

Combined digital and analogue indication

2 probe inputs for single measurements, sum and difference measurements

- Large LC display for comfortable and error-free reading.
- Pseudo-analogue bargraph indication for a better repeatability and negligible hysteresis.
- Choice between pointer or bargraph indication.
- LCD display for all functions.
- 7 measuring ranges, switchable manually or automatically according to the measured value.
- Direct conversion from metric to inch units.
- Touch button for the indication setting of of each measuring channel.
- Keys for introducing limit values.
- Classification of values (3 classes) and display through colour LEDs with signal outputs.
- Locking of displayed values for step by step measurement routines.
- Automatic recognition of the type of connected TESA probe with adaptation of the measurement signals to the value of output connected (valid only for TESA probes produced from 1997 onwards).
- Opto-coupled RS232 output, bidirectional.
- Power supply through mains adapter.

TESATRONIC TT60

Same features as TESATRONIC TT20, but with following added functions:

- Memory for retaining extreme values "max.", "min.", "max.-min." along with mean value obtained from "max." minus "min.".
- Dynamic measurement with acquisition of >100 single values.
- Value classification with output signals through contact relay for 5, 10, 20 or 40 acceptable classes.
- Analogue output for exterior processing of signals.





TT60



TT20

| No | = | * (Measuring range zoom x5) | * (Memory) |
|----------|--|-----------------------------|------------|
| 04430009 | TESATRONIC TT20 Display unit for 1 or 2 inductive probes | - | - |
| 04430010 | TESATRONIC TT60 Display unit for 1 or 2 inductive probes | - | ● |



|  |  |  |
|---|---|---|
| | Number of probe inputs | Automatic switching of range |
| TESATRONIC TT60 Display unit for 1 or 2 inductive probes | | ● |
| TESATRONIC TT20 Display unit for 1 or 2 inductive probes | | ● |

DELIVERED WITH THE FOLLOWING ACCESSORIES:

| | |
|-----------------|--|
| 04761054 | Battery charger 100 ÷ 200 VAC 50 ÷ 60 Hz, 6,6 V DC, 750 mAh supplied without power cable |
| 04761055 | Mains cable EU for charger 0471054 |

OPTIONAL ACCESSORIES:

| | |
|-----------------|--|
| 04768000 | Hand switch for manually triggering data transfer. Jack plug connector, 1,8 m – TESA SPC PRINTER printer – TESATRONIC TT display units |
| 04768001 | Foot switch for triggering data transfer. Jack plug, 1,8 m – TESA SPC PRINTER printer – TESATRONIC (TT) display units |
| 04761062 | Opto-USB cable, Duplex, 2m Bidirectional communication |
| 04761049 | Opto-RS cable, Duplex, 2m Bidirectional communication |

 For a temperature of 20°C and a relative humidity of ≤ 50 %:
TT20:
Response time of analogue, digital and LED classification displays: ≤ 80 ms.
Maintenance of digital display: 80 ms.
TT60:
Response time of analogue, digital and LED classification displays: ≤ 80 ms.
Holding of digital display: 80 ms.
Response time of the analogue output signal in relation to analogue display: ≤ 30 ms.

 RS232 opto-coupled output

 TT60: Voltage Range: ± 2 V to ± 10 V. Output current: ≤ 2 mA. Load adjustment: ≥ 5 kΩ. Background noise (probe at electrical zero) ≤ 1 mV. Reference potential: ground 0 V.

 Supply: 6,5 V DC up to 7,3 V DC. Supply frequency: 13 ± 0,65 kHz. Power consumption: 2 W. Monitored voltage variations. Probe supply voltage: 3 V.

 0°C to 60°C

 -10°C to 70°C

 80 %, without condensation

 Protection of frontal face: IP54 (IEC 60529, DIN 40 050)

 IEC/EN 61326-1
USA: CFR47, Part 15, Subpart B, Class B, Digital Device

 1,1 kg

 Transport packaging

 Identification number

 Declaration of conformity



- DIN 32876 Part 1
- 110 mm scale length
- 50 scale divisions
- 6-decade display plus minus sign
- 12,5 x 6,6 mm
- 126 x 62 mm LCD display
- Limit value for a temperature of 20°C and a relative humidity of ≤ 50 %:
Analog display: 2 %
Digital display: 0,15 %
Analog output: 0,3 %
Digital output: 0,15 %
- ± 1 digital interval
- 255 x 235 x 120 mm (W x D x H)
- Resistant plastic

TESATRONIC TT 80 and TT 90 Probe Display Units

High resolution display units

Combined analogue/digital display

Two probe inputs for single, sum and difference measurements.

In addition to TESATRONIC TT60 functions, TT 80 has the following additional functions:

- 9 measuring ranges with digital steps of 0,01 µm or 0.000001 in.
- Memorisation of extreme values "max.", "min.", "max. minus min." as well as the mean of the two values "max." and "min."
- Dynamic measurement with acquisition of more than 10 single values per second.
- Classification of measured values with a contact relay providing output signals for 5, 10, 20 or 40 acceptable classes.
- Analogue output for external processing of signals.

In addition to TESATRONIC TT60 functions, TT 90 has the following additional functions:

- 9 measuring ranges with digital step of 0,01 µm or 0.000001 in.
- Memorisation of extreme values "max.", "min.", "max. minus min." plus the mean of both values "max." and "min."
- Dynamic measurement with acquisition of more than 10 single values per second.
- Classification of measured values with output signals through contact relay for 5, 10, 20 or 40 acceptable classes.
- Analogue output for external signal processing.
- Output for bolt retraction control.
- Selection of stabilisation time for measuring cycles.
- RS digital output for values to the micron.



TT 90



TT 80



Application: TT 80 with a SIP (Société genevoise d'instruments de physique) high precision measuring bench

| No | = | | |
|----------|--|-------------------------|--------|
| | | Measuring range zoom x5 | Memory |
| 04430011 | TESATRONIC TT80 High precision electronic display | - | ● |
| 04430012 | TESATRONIC TT90 High precision electronic display | - | ● |

| = | | |
|---|-------------------------|-------------------------------|
| | Number of probes inputs | Automatic conversion of range |
| TESATRONIC TT80 High precision electronic display | 2 | ● |
| TESATRONIC TT90 high precision electronic display | 2 | ● |





DELIVERED WITH THE FOLLOWING ACCESSORIES:

| | |
|-----------------|---|
| 04761054 | Battery charger 100 ÷ 200 VAC / 50 ÷ 60 Hz, 6,6 V DC, 750 mAh, supplied without power cable |
| 04761055 | Mains cable EU for charger 0471054 |

OPTIONAL ACCESSORIES:

| | |
|-----------------|--|
| 04768000 | Hand switch for manually triggering data transfer. Jack plug connector, 1,8 m - TESA SPC PRINTER printer - TESATRONIC TT display units |
| 04768001 | Foot switch for triggering data transfer. Jack plug, 1,8 m - TESA SPC PRINTER printer - TESATRONIC (TT) display units |
| 04761062 | Opto-USB cable, Duplex, 2m Bidirectional communication |
| 04761049 | Opto-RS cable, Duplex, 2m Bidirectional communication |

 For a temperature of 20°C and a relative humidity of ≤ 50 %: Response time analogue, digital and LED displays classification: ≤ 100 ms. Holding of digital display: 100 ms. Response time of the analogue output signal in relation to analogue display: ≤ 30 ms.

 For a temperature of 20°C and a relative humidity of ≤ 50 %: Zero drift and signal amplification: ≤ 0,005 %/°C. No drift of stored values. Frequency limit for all displays frequency, analog output and memory in relation to input signal: 10 Hz

 RS232 opto-coupled output

 Voltage range of ± 2 V to ± 10 V. Output current: ≤ 2 mA. Load adjustment: ≥ 5 kΩ. Background noise (probe to 0 electric) ≤ 1 mV. Reference potential: analog ground 0 V

 6,5 Vdc up to 7,3 V DC. Consumption: 2 W. Monitored voltage fluctuation. Supply voltage for probe: 3 V

 0°C to 60°C

 -10°C to 70°C

 80 %, without condensation

 Protection of frontal face: IP54 (IEC 60529, DIN 40 050)

 IEC/EN 61326-1
USA: CFR47, Part 15, Subpart B, Class B, Digital Device

 1,1 kg

 Transport packaging

 Identification number

 Declaration of conformity



TESATRONIC TTA20 Probe Display Unit

Compact design with analogue indication and value classification of measured values.

Aluminium housing, designed for shop floor applications, user-friendly.

- Easy-to-read analogue display with mirror strip in order to avoid parallax error.
- 6 measuring ranges.
- Metric/Inch conversion.
- Zero setting potentiometer for display.
- 2 probe inputs for single, sum or difference measurements.
- 1 auxiliary signal input, e.g. for all correction values.
- Colour LEDs of green for "Good", yellow for "Rework" and red for "Scrap".
- Potentiometer for setting limit tolerances.
- Polarity reverse switch for classification signals (internal or external dimensions).
- Switch for locking or unlocking a displayed value.
- Analogue output for a display unit or external recording.



TTA20

- DIN 32876 Part 1
- Length: 100 mm
- Limit value for a temperature of 20°C and a relative humidity of ≤ 50 %: Analog Display: 1,5 % Analog output: 0,3 %
- Display: negligible. Classification signals: 5 %
- 258 x 190 x 158 mm (W x D x H)
- Die-cast aluminum case, designed for the workshop
- For a temperature of 20°C and a relative humidity of ≤ 50 %: Response time of the analogue display: ≤ 1 ms. Response time of the analogue output signal from the analog display: 20 ms. Response time for classification signals: 10 ms.
- For a temperature of 20°C and a relative humidity of ≤ 50 %: Zero drift: ≤ ± 0,005 % /°C. No drift of stored values. Frequency limit for analogue display: 1 Hz. Frequency limit for analogue output: 50 Hz. Frequency limit for classification: 30 Hz

| | | Number of measuring ranges Min range / Max range max (µm) | Measuring range zoom x5 | Memory | Power supply |
|----------|-------|---|-------------------------|--------|--------------|
| 04430003 | TTA20 | 6 / min ± 3 max ± 1000 | – | – | Network |

DELIVERED WITH THE FOLLOWING ACCESSORIES:

| | |
|----------|---|
| 03160015 | Mains cable CH 2 m |
| 03160016 | Mains cable, EU, 2 m |
| 03160017 | Mains cable without plug, 2 m for TTA20 |

OPTIONAL ACCESSORY:

| | |
|----------|--|
| 04460004 | Connector 15 pins for analogue output and classification signal of TTA20 |
|----------|--|

| µm | µm | in | in |
|--------|-----|----------|---------|
| ± 1000 | 50 | ± 0.1 | 0.005 |
| ± 300 | 10 | ± 0.03 | 0.001 |
| ± 100 | 5 | ± 0.01 | 0.0005 |
| ± 30 | 1 | ± 0.003 | 0.0001 |
| ± 10 | 0,5 | ± 0.001 | 0.00005 |
| ± 3 | 0,1 | ± 0.0003 | 0.00001 |

| Number of probe inputs | Automatic conversion of range |
|------------------------|-------------------------------|
| 2 | – |



Accessories for TESATRONIC TT Units



04761055



04761056



04761054



03160017



03160015



03160016



Template for TT10 display

Voltage: ± 1 V. Output current ≤ 3 mA. Adjustment load ≥ 2 k Ω . Residual ripple (at electrical zero): ≤ 1 mV. Reference potential: analogue ground 0 V

Supply voltage 230 or 115 V -10% to +20%, 50-60 Hz. Virtual power: 20 VA. Supply voltage for probe: 1,5 Vrms -10% to +5%. Frequency: 13 kHz $\pm 0,5$ %.

0°C to +50°C

-10°C to +70°C

Level of protection: IP40 (IEC 60529)

EN 50081-1
EN 50081-2
EN 50082-1
EN 50082-2

3,4 kg

Transport packaging

Identification number

Declaration of conformity

No

=

| | |
|----------|--|
| 04761054 | Battery charger 100 ÷ 200 VAC 50 ÷ 60 Hz, 6,6 V DC, 750 mAh supplied without power cable |
| 04761055 | Mains cable EU for charger 0471054 |
| 04761056 | Mains cable US for charger 0471054 |
| 03160015 | Mains cable CH, 2 m for TTA20 |
| 03160016 | Mains cable EU, 2 m for TTA20 |
| 03160017 | Mains cable without plug, 2 m for TTA20 |
| 04460007 | 10x templates for TT10 |
| 04460004 | Connector 15 pins for analogue output and classification signal of TTA20 |
| 04768002 | 3 AA 1,5 V batteries, type LRC 6 for TT10 |



ELECTRONIC INTERFACE UNITS

Electronic interfaces to manage, synchronize inductive probes and allow data transfer to a computer or an automatic inspection machine.

TESA Probe Interface Boxes - BPX Series

Modular system available in 2 versions (BPX and TWIN-STATION) for the conversion of measured signals to digital values and transmission of these values to a computer. These units are key components for multigauging inspection fixtures for centralised process control systems.

Signal inputs – 1 to 4 TESA standard half-bridge probes.

Signal output – digital, RS232 through USB port.

- Direct connection to the computer's USB port.
- Stand Alone operating mode: program routine via the computer, enabling the BPX box to execute a simple measuring function with classification signal relay via connector Sub-D 15P.
- Optimal adaptation for various measuring applications, for example, connection of 16 probes thanks to serial USB connections on 4 BPX boxes.
- Increased functional reliability and high precision.
- Increased immunity to negative environmental effects, whether of electrical origin or provoked by liquid and solid contaminants.
- BPX is compatible and can be used with TWIN-STATION.
- TIS interface software is included in the BPX (part number 05030012) for display of measured values. Possibility of indicating tolerance values, and simple functions +A, -A, +A+B, +A-B, export of values to a .csv file.



BPX Front

BPX Rear



TIS software included in the BPX supply

- ±2 mm, ±5 mm
- 0,1 µm
- Field error indication (pictogram / text) to a temperature of 20°C and a relative humidity of ≤ 50 %: Digital output: ±(0,05 + 0,15 % of range)
- 55 x 172 x 155 mm (H x W x D)
- Housing in aluminium
- For a temperature of 20°C and a relative humidity of ≤ 50 %: Zero drift: ≤ ± 0,05 %/°C. Sensitivity drift: ≤ ± 0,05 %/°C. Acquisition time: 10 ms (between two consecutive measurements) 1 ms (timing window) time data transfer of digital serial output (USB): depends on the operating system of the computer.
- USB port (USB Hub) Communication: USB 2.0, 3 external ports (≤ 100 mAh)
- Supply voltage of the charger: 115 to 230 Vrms, charger frequency 50 ÷ 60 -10 to +15 % Hz
- 10°C to 40°C
- 10°C to 70°C
- 80 %, without condensation
- IP40 (IEC 60529) (DIN 40050)
- IEC/EN 61326-1 U.S. 47 CFR part 15, subpart B, Class B digital device
- 1 kg (BPX) 0,85 kg (TWIN Station)
- Power supply 100 ÷ 240 V, 50 ÷ 60 Hz (04761054) EU Cable, CH (04761055) U.S. Cable (04761056)
- Packed suitable for transport
- Identification number
- Declaration of conformity

| No | A | ✳ | ✳ |
|----------|-----------------------------|---|--|
| 05030010 | Number of probe inputs 4 | Number of I / O (In / Out) controllers 1 / 3 | Connector Sub-D 15 p/f (for In/Out signals) |



TWIN-STATION Receiver for TESA Wireless Probes



GTL 21 W wireless probe with VERIBOR (optional)

Modular system available in 2 executions (TWIN Station and BPX) for the conversion of inductive probe signals into digital values for transmission to a computer. These units are important components for measuring fixtures requiring freedom of movement without any constraints and without any cables, a wireless transmission

Signal inputs – 1 to 8 TESA half-bridge wireless probes*

Signal outputs – digital, RS232 through USB port

- Direct connection to the USB port of the computer.
- Perfect fit for your metrology applications through the connection of up to 32 wireless probes by means of serial USB to 4 TWIN-Station units.
- Great functional reliability and high accuracy.
- TWIN Station is compatible and can be used with BPX.
- TIS interface software TIS included in supply of TWIN-STATION (part no. 05030012): display of measured values. Possibility of indicating tolerances, simple functions +A, -A, +A+B, +AB, and export of values to a .Csv file.

Note: The sale of TWIN-STATION is limited to EU countries, Switzerland, USA and Canada.

* The sale of wireless probes is limited to EU countries, Switzerland, USA, Canada and China.



TWIN Station, front



TWIN Station, rear

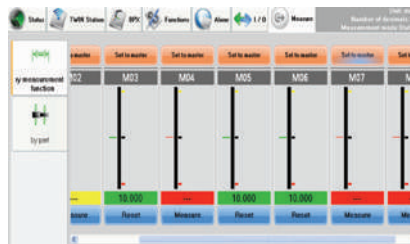

TIS Software, included in the Twin Station supply

- ± 2 mm, ± 5 mm
- 0,1 µm
- For a temperature of 20°C and a relative humidity of ≤ 50 %: Digital output: ± (0,05 + 0,15 % of measuring range)
- 55 x 172 x 155 mm (H x W x D)
- Housing case in aluminium
- For a temperature of 20°C and a relative humidity of ≤ 50 %: Zero drift: ≤ ± 0,05 %/°C. Sensitivity drift: ≤ ± 0,05 %/°C. Acquisition time: 20 ms (between two consecutive measurements) 2 ms (timing window) Time for data transfer from digital serial output (USB): depends on the operating system of the computer
- Power supply via USB cable connection – directly to PC (USB port) – to a USB-connected hub – to a BPX probe interface (05030010)
- 10°C to 40°C
- 10°C to 60°C
- 80 %, without condensation
- IP40 (IEC 60529) (DIN 40050)
- IEC/EN 61326-1 U.S.47 CFR part 15, subpart B, Class B digital device
- 0,85 kg
- USB cable, 1,80 m
- Transport packaging
- Identification number
- Declaration of conformity

| No | Number of wireless probes per TWIN Station | Power supply | Weight, kg |
|----------|--|---|------------|
| 05030012 | 1-8 | Power supply via: – USB port of PC – USB-connected hub – BPX | 0,85 |



± 0,5 % with reference to the measuring span



± 10 to ± 15 V DC, 60 mA



≤ ± 100 ppm/°C, stability at zero = ≤ ± 0,2 μm/°C



15°C to 40°C



-10°C to 70°C



30% to 80 %, without condensation



IP50 (IEC 60529)



Transport packaging

TESA Probe Interface Boxes with Analogue Output – Series M4P-2

Signal inputs – TESA standard execution probes (Half-bridge)

Signal outputs – analogue (in ± V/mm)





- Connection of up to 32 TESA standard half-bridge probes.
- Connection possible to a PC through the A/D transducer.

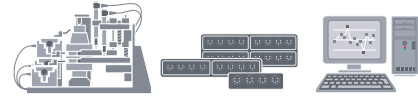

Rack with 3 M4P-2 interfaces



Multi-gauging fixture with 1, 2 or 4 M4P-2 interfaces

| No | = |  |  |  |  |  |
|-----------|---|---|---|--|---|---|
| | | Sensitivity (mV / V / mm) | Number of probe inputs | Dimensions (mm) | Analogue outputs | Weight (kg) |
| S48001721 | M4P-2 interface 4 probe inputs with demodulator and analogue output in V/mm | 73,75 | 4, including a demodulator | 36 x 100 x 120 | ± 1 V/mm, ± 2,5 V/mm, ± 5 V/mm, ± 10V/mm | 0,6 |
| S48001722 | R2M-1 rack for 2x M4P-2 | – | 8 (with 2x M4P-2) | 55 x 212 x 144 | – | 0,9 |
| S48001723 | R4M-1 rack for 4x M4P-2 | – | 16 (with 4x M4P-2) | 160 x 212 x 144 | – | 1,2 |
| S48001724 | Supply module MA4-2, 230V | – | Voltage: 230 ± 10 % Vac, 50 Hz | 85 x 222 x 146 | Output voltage: ± 15V for 32 probes | 1,1 |
| S48001731 | Power supply MA4-2, 110 V | – | Voltage: 110 ± 10 % Vac, 60 Hz | 85 x 222 x 146 | Output voltage: ± 15V for 32 probes | 1,1 |

Accessories for M4P-2 probe interface

| No | = |
|-----------|---|
| S48001725 | M4P-2 connecting cable to PC, 2m DB-37 pins m/f |



Adaptor Cable: DIN 5p Connector to USB Type A Connector

Allows for quick and easy connection of any TESA standard half bridge probe to a PC USB port.

Signal inputs – TESA standard probes (Half-bridge)

Signal outputs – digital RS 323 through USB port

| No | = | | | |
|----------|--|---------------------|------------------------------|-------------|
| | | Measuring range, mm | Deviation span of indication | Zero drift |
| 03260500 | Cable adapter DIN 5p for USB. enables connection of TESA probes sensitivity 73,75 mV/V/mm directly to a USB port | ± 2 mm | 0,3 % ± 0,1 µm | ± 0,01 %/°C |
| 03260501 | Cable adapter DIN 5p for USB. enables connection of TESA probes sensitivity 29,50 mV/V/mm directly to a USB port | ± 5 mm | 0,3 % ± 0,1 µm | ± 0,01 %/°C |



Cable adapter: DIN 5-pin connector to USB connector type A



At 20°C and relative humidity ≤ 50 %:
error of indication = 0,3 % ± 0,1 µm zero drift ± 0,01 %/°C V.
Standard refresh speed = 80 ms.
Maximum refresh speed = 42 ms.
Distance between the stops and the electrical zero cannot be adjusted.
Length of cable: 1,2 m. Note: the total error should take into account the error of the probe and the error of the adapter.



USB 2.0 RS232, virtual COM port

See table

20 ± 0,5°C

10°C to 40°C

80 %

IP51 (IEC 60529)

Packed suitable for shipping

Serial number identification





Input impedance
 $970 \pm 50\Omega$ (13 kHz)
 or $2150 \pm 50\Omega$
 (standard $0 \mu\text{m}$)
 Phase (13 kHz):
 $71 \pm 2^\circ$. Input
 resistance:
 $100 \pm 5\Omega$. Output
 impedance at
 13 kHz: $1000 \pm 2\Omega$.
 Phase (13 kHz): $0,2^\circ$
 Dummy probe (half-
 bridge), sensitivity
 $73,75 \text{ mV/V/m}$.
 Suitable for
 instruments with
 following features:
 Frequency: 13
 $\pm 0,65 \text{ kHz}$, Voltage:
 $3 \pm 0,015 \text{ Veff}$ (2
 symmetrical voltages
 of $1,5 \text{ Veff}$) Input and
 output impedance:
 $\leq 0,2\Omega$ et 2000Ω ,
 respectively



-10°C to 70°C



10°C to 35°C



Calibration: 40 % to
 60 %. Operating:
 20 % to 80 %.
 Storage: 5 % to
 95 %. Without
 condensation.



IP40 (IEC 60529)



Inspection report



$\emptyset 18 \text{ mm}$, length
 118 mm



$\approx 45 \text{ g}$



$20 \pm 0,5^\circ\text{C}$, stabilisa-
 tion time = 8 h



$\pm 3 \text{ ppm}/^\circ\text{C}$. Ageing:
 $\pm 30 \text{ ppm/a}$

Calibration Standards – Dummy Probes

Calibration standards – also known as "dummy probes" – are resistance dividers. Each calibration standard simulates a given length dimension with high accuracy. Each calibration standard has 2 values (positive and negative). The values indicated below are the nominal values.

These products are calibrated and supplied with an inspection report that shows the values (actual values) measured during calibration and the related measuring uncertainty.

The calibration standards are connected to the instrument in place of regular probes. For the calibration and all required setting operations of the instrument, certain criteria and conditions need to be respected. Consult the user manual or get in touch with our specialists for further information.



Set of 3 calibration standards (S41077249)

| No | = | Value of the calibration standard (microns) |
|-----------|-----------------------|---|
| S41078077 | Dummy probe | ± 0 |
| S41078079 | Dummy probe | ± 3 |
| S41078228 | Dummy probe | ± 100 |
| S41078230 | Dummy probe | ± 190 |
| S41078087 | Dummy probe | ± 300 |
| S41078332 | Dummy probe | ± 500 |
| S41078751 | Dummy probe | ± 1000 |
| S41078752 | Dummy probe | ± 1900 |
| S41077249 | Set of 3 dummy probes | $\pm 0 / \pm 100 / \pm 1000$ |
| S41078654 | Set of 2 dummy probes | $\pm 190 / \pm 1900$ |



INSERTS FOR AXIAL PROBES, WITH M2 THREAD

Extensions for Inserts with M2 Thread

| No | | L, mm |
|----------|--|-------|
| 03540505 | | 10 |
| 03540506 | | 15 |

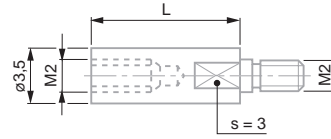

03540505, 03540506

Measuring Insert with Cylindrical Measuring Face, Lock Nut for Radial Alignment, M2 Thread

| No | | | L, mm |
|----------|---------|--|-------|
| 03510503 | Carbide | | 6 |

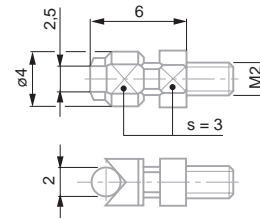

03510503

Hemispherical Measuring Inserts, M2 Thread

| No | | | R, mm | Material | L, mm |
|----------|--|--|-------|----------|-------|
| 03510204 | | | R 1 | Carbide | 3 |
| 03510103 | | | R 5 | Carbide | 3 |

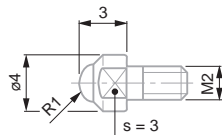

03510204

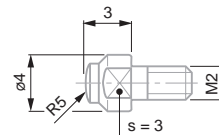

03510103

Spherical Measuring Inserts, R = 5 mm, M2 Thread

| No | | | L, mm |
|----------|---------|--|-------|
| 03510202 | Carbide | | 16 |
| 03510203 | Carbide | | 26 |

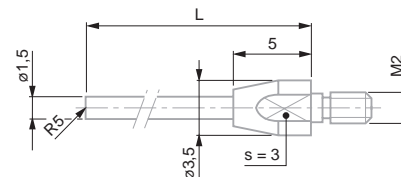

03510202, 03510203



INSERTS FOR AXIAL PROBES, WITH M2,5 THREAD

Extensions for Measuring Inserts, $\varnothing 4$ mm, 10 – 40 mm

| No | | L, mm |
|----------|--|-------|
| 03540501 | | 10 |
| 03540502 | | 15 |
| 03540503 | | 20 |
| 03540504 | | 40 |

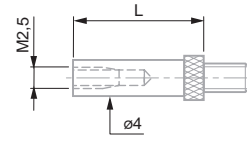

03540501 to 03540504

Standard Spherical Measuring Inserts, $R = 1,5$ mm, $L = 6$ mm

| No | | | | L, mm |
|----------|--------|----------|--|-------|
| 03510001 | L=6 mm | Steel | | 6 |
| 03510002 | L=6 mm | Carbide | | 6 |
| 03560001 | L=6 mm | Sapphire | | 6 |

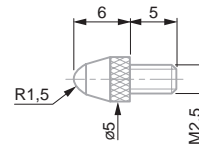

03510001, 03510002, 03560001

Spherical Measuring Insert with 4 Interchangeable Pins, $R = 1,5$ mm, Length 16-46 mm

| No | | | L, mm |
|----------|-------|--|----------------|
| 03510201 | Steel | | 16, 26, 36, 46 |

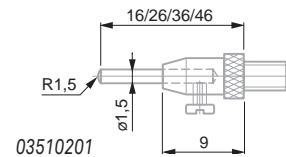

03510201

Spherical Measuring Inserts, $R = 5$ mm, $L = 6$ mm

| No | | | L, mm |
|----------|---------|--|-------|
| 03510101 | Steel | | 6 |
| 03510102 | Carbide | | 6 |

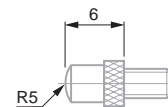

03510101, 03510102

Insert with Cylindrical Measuring Face, Counter Nut for Radial Alignment

| No | | | L, mm |
|----------|---------|--|-------|
| 03510502 | Carbide | | 6 |

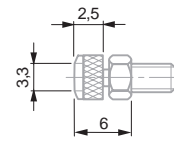

03510502

Spherical Measuring Inserts, $R 1 - 8$ mm, $L > 18$ mm

| No | | | \varnothing , mm |
|----------|---------|--|--------------------|
| 03560051 | Carbide | | 1 |
| 03560052 | Carbide | | 2 |
| 03560053 | Carbide | | 3 |
| 03560054 | Carbide | | 4 |
| 03560055 | Carbide | | 5 |
| 03560056 | Carbide | | 6 |
| 03560057 | Carbide | | 7 |
| 03560058 | Carbide | | 8 |

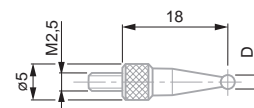

03560051 to 03560058



INSERTS FOR AXIAL PROBES, WITH M2,5 THREAD

Inserts with a Flat Measuring Face $\varnothing 1,5$ mm, Interchangeable Pin, Steel or Carbide

| No | \varnothing | Material | L, mm |
|----------|---------------|----------|-------|
| 03560008 | 1,5 | Steel | 20 |
| 03560009 | 1,5 | Carbide | 20 |

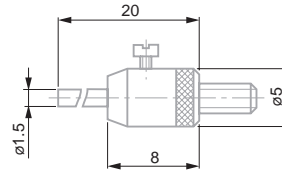

03560008, 03560009

Inserts with Flat Measuring Face, $\varnothing 2$ mm, Steel

| No | \varnothing | L, mm | L1, mm |
|----------|---------------|-------|--------|
| 03560026 | 2 | 5 | 2,8 |
| 03560027 | 2 | 10 | 7,8 |
| 03560028 | 2 | 15 | 12,8 |
| 03560029 | 2 | 20 | 17,8 |

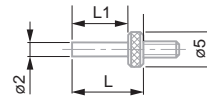

03560026 to 03560029

Insert with Offset (6,5 mm) Measuring Contact Point, Lock Nut for Radial Alignment

| No | Material | L (offset), mm |
|----------|----------|----------------|
| 03510401 | Steel | 6,5 |

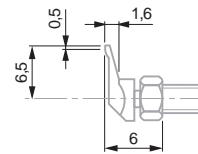

03510401

Inserts with a Flat Measuring Face, $\varnothing 2,5 - 3,4$ mm

| No | \varnothing | Material | L, mm |
|----------|---------------|----------|-------|
| 03510801 | 2,5 | Steel | 6 |
| 03510802 | 2,5 | Carbide | 6 |
| 03560022 | 3,4 | Steel | 8 |
| 03560023 | 3,4 | Carbide | 8 |

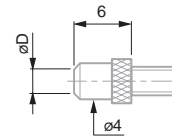

03510801, 03510802, 03560022, 03560023

Inserts with Flat Measuring Face, $\varnothing 5 - 10 - 20$ mm

| No | \varnothing | Material | L, mm |
|----------|---------------|----------|-------|
| 03560012 | 5 | Steel | 5 |
| 03560013 | 5 | Carbide | 5 |
| 03560014 | 10 | Steel | 6 |
| 03560015 | 10 | Carbide | 6 |
| 03560016 | 20 | Steel | 3,6 |

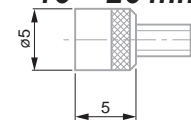

03560012, 03560013

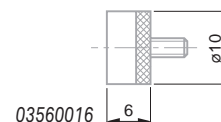

03560016

Insert with Off-centre (6,5 mm) Narrow Face, Lock Nut for Radial Alignment

| No | Material | B (measuring face contact), mm |
|----------|----------|--------------------------------|
| 03510602 | Carbide | 0,5 |

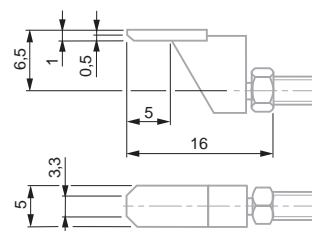

03510602



INSERTS FOR AXIAL PROBES, WITH M2,5 THREAD

Insert with a Flat Measuring Face, \varnothing 2,5 mm, Adjustable Parallelism, Counter-nut for Radial Alignment

| | | | |
|----------|-----|---------|----|
| | | | |
| 03510902 | 2,5 | Carbide | 16 |

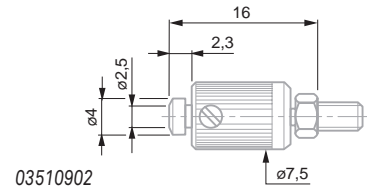

Insert with Offset (12 mm) Contact Point, Lock Nut for Radial Alignment

| | | | |
|----------|-------|----------------|----|
| | | | |
| 03560063 | Steel | L (offset), mm | 12 |

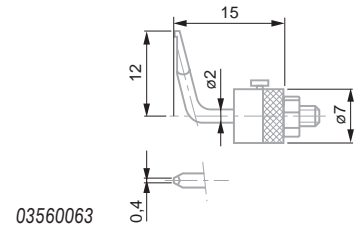

Insert with Narrow Measuring Face, Adjustable Parallelism, Counter-nut for Radial Alignment

| | | | |
|----------|---------|-------|-----|
| | | | |
| 03510702 | Carbide | B, mm | 0,5 |

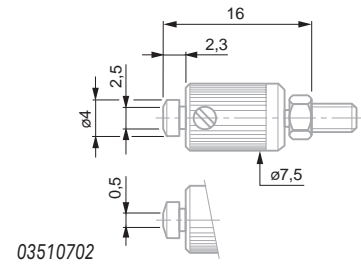

Inserts with Blade-shaped Measuring Face, Lock Nut for Radial Alignment

| | | | |
|----------|---------|-------|------------------------|
| | | | |
| | | L, mm | B (measuring face), mm |
| 03560024 | Steel | 8 | 0,3 |
| 03560025 | Carbide | 8 | 0,3 |

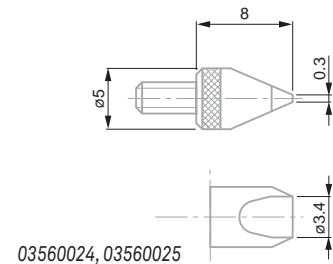

Measuring Inserts with Ball-bearing Rollers, Lock Nut for Radial Alignment

| | | | |
|----------|--------------|-------|-------|
| | | | |
| | Roller shape | L, mm | |
| 03560010 | Cylindrical | Steel | 17,25 |
| 03560011 | Domed | Steel | 17,25 |

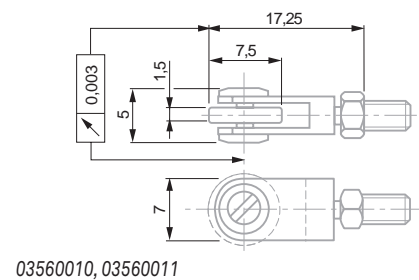

Insert with Needle Contact Point

| | |
|----------|--|
| | |
| 03560030 | |

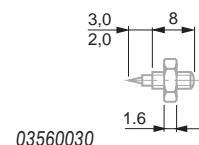

SPRING SETS, BELLOWS, CLAMPING ELEMENTS, MANUAL RETRACTION FOR AXIAL PROBES

Spring Sets for Axial Probes

| No | = | Measuring force (N) |
|----------|-------------------------|---------------------|
| 03260419 | Spring sets for GT22 | 0,16 |
| 03260420 | Spring sets for GT22 | 0,25 |
| 03260457 | Spring sets for GT21/22 | 0,63 |
| 03260422 | Spring sets for GT21/22 | 1,0 |
| 03260423 | Spring sets for GT21/22 | 1,6 |
| 03260424 | Spring sets for GT21/22 | 2,5 |



All values given in the table for the measuring force equal nominal values at electrical zero; max. deviation $\pm 25\%$. Valid for upright assembly position with downward oriented measuring bolt, and used in static measurement.



Plastic sleeve marked with force related data



Packed suitable for transport

Bellows for Axial Probes

| No | = | |
|----------|--|---------|
| 03260468 | For 4,3 mm bolt travel GT 21, 22, GTL 21, 211, 22 | Nitrile |
| 03260470 | For 4,3 mm bolt travel GT 21, 22, GTL 21, 211, 22 | Viton |
| 03260489 | For pressure probe 4,3 mm bolt travel GTL 212, 222 | Viton |
| 03260491 | For 10,3 mm bolt travel GT 27, 271, 28, 61, 611, 62 | Viton |
| 03260490 | For pressure probe 10,3 mm bolt travel GT 272, 282, 612, 622 | Viton |

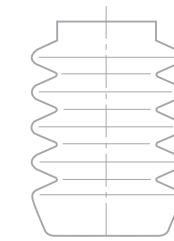

Protection bellow



Nitrile: resistant synthetic sealing for normal use. Viton: high-resistance synthetic sealing. Used in conditions where probes are permanently exposed to coolants and lubricants.



Packed suitable for transport

Clamping Elements for Axial Probes

Elements with 3 clamping faces – Prevents any deformation of the measuring bolt guiding system, thus preserving all the metrological properties of the probe.

| No | = | ∅ | A mm |
|----------|---------------------|----------------------------------|------|
| 02611013 | VKD clamping screw | | M4 |
| 02611014 | VKE clamping sleeve | ∅ 8 mm | |
| 01860401 | Y61 fixing clamp | ∅ 5,6 mm and ∅ 9,5 with dovetail | |
| 02660048 | VDE 28 probe holder | ∅ 8 mm | |



All dimensions to be noted are shown in the drawing.



Packed suitable for transport

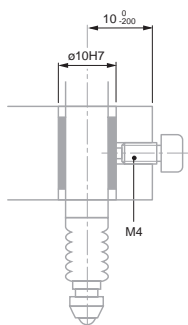

Fixing clamp for axial probe

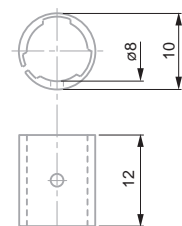

VKE – clamping sleeve

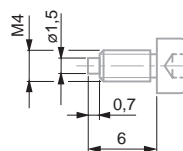

VKD – clamping screw

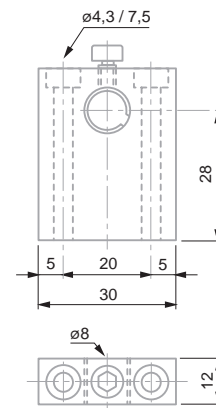

VDE – clamping élément with sleeve and clamping screw





Packed suitable for transport

Manual Measuring Bolt Retraction for Axial Probes

| No | = | |
|----------|-------------------------------------|---|
| 03540104 | TB 11 retraction device components | Consisting of: - 1 Washer TB102 (03540102) - 1 Lifting Lever TB101 (03540101) |
| 03260401 | Manual pneumatic retraction device. | Suitable for GT 22, 271, 28, 42, 44, 611, 62 – GTL211, 22 probes Consisting of: - 1 hand-operated vacuum pump - 1 tube of 1m, Ø 4,7 mm (ref. 03540405) |
| 03540405 | TB311 flexible tube | |



Stainless steel measuring insert, carbide ball tip

Packed suitable for transport

ACCESSORIES FOR GT 31 LEVER PROBES

Probe Inserts for GT 31 Lever Probes

| No | Ø | Lever – amplification | L, mm | A |
|----------|---|-----------------------|-------|-----------------|
| 03260402 | 1 | 1:1 | 32 | One-piece shaft |
| 03260410 | 2 | 1:1 | 32 | One-piece shaft |
| 03260403 | 3 | 1:1 | 32 | One-piece shaft |
| 03590002 | 1 | 1:1 | 32 | Two-piece shaft |
| 03590003 | 2 | 1:1 | 32 | Two-piece shaft |
| 03590004 | 3 | 1:1 | 32 | Two-piece shaft |
| 03590005 | 4 | 1:1 | 32 | Two-piece shaft |

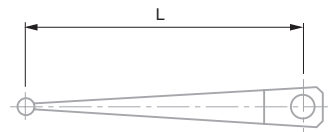

03260410



03260410



Packed suitable for transport

Fixing Bracket for TESA GT 31 Lever Probe

| No | = | |
|----------|---|--|
| 03240100 | Fixing bracket with dovetail clamp or cylindrical bore for GT31 probe | |

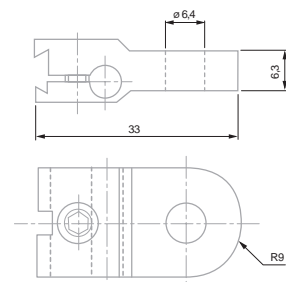

03240100



INSERTS WITH Ø 4 MM MOUNTING SHAFT, FOR FMS PROBES

Probe Inserts with a Flat Rectangular Face, Ø 4 mm Mounting Shaft for FMS Probes

| No | | | L, mm |
|----------|---------|----|-------|
| 02660066 | Carbide | 12 | |
| 02660068 | Carbide | 25 | |
| 02660067 | Carbide | 12 | |
| 02660069 | Carbide | 25 | |

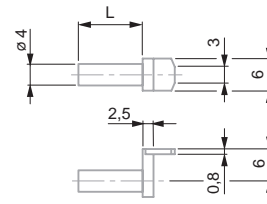

02660067, 02660069

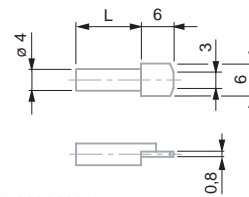

02660066, 02660068

Probe with 2 Cylindrical Measuring Faces with Ø 4 mm Mounting Shaft, for FMS Probes

| No | | | L, mm |
|----------|---------|----|-------|
| 02660070 | Carbide | 20 | |
| 02660071 | Carbide | 40 | |
| 02660072 | Carbide | 60 | |
| 02660082 | Carbide | 40 | |
| 02660083 | Carbide | 60 | |

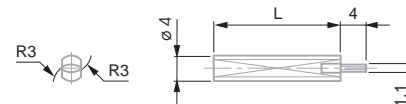

02660070, 02660071, 02660072

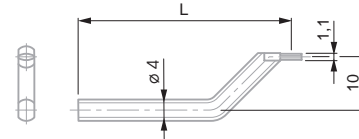

02660082, 02660083

Insert with Ø = 2 mm Diameter Contact Pin, Hemispherical Face with Ø 4 mm Diameter Mounting Shaft for FMS Probes

| No | | | L, mm |
|----------|---------|----|-------|
| 02660074 | Carbide | 40 | |

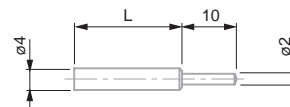

02660074

Probe with Ball Tip Ø 4 mm for FMS Probes

| No | | | L, mm |
|----------|---|---------|-------|
| 02660076 | 3 | Carbide | 20 |
| 02660077 | 3 | Carbide | 40 |
| 02660078 | 3 | Carbide | 60 |
| 02660079 | 5 | Carbide | 20 |
| 02660080 | 5 | Carbide | 40 |
| 02660081 | 5 | Carbide | 60 |
| 02660084 | 5 | Carbide | 20 |
| 02660085 | 5 | Carbide | 33 |

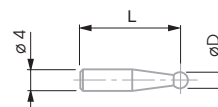

02660076 to 02660081

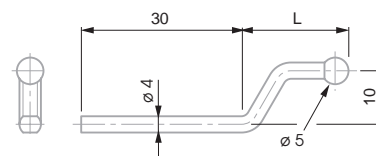

02660084, 02660085



Packed suitable for transport



Packed suitable for transport



Packed suitable for transport



Packed suitable for transport





Packed suitable for transport

INSERTS WITH Ø 6 MM MOUNTING SHAFT, FOR FMS PROBES

Inserts with Ball Tip, Ø 6 mm Mounting Shaft, for FMS Probes

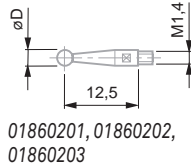

| No | Ø | Material | L, mm |
|----------|--------|----------|-------|
| 00760058 | 3 | Carbide | 55 |
| 00760059 | 5 | Carbide | 56 |
| 00760060 | 10 | Carbide | 55 |
| 01860201 | 1 | Carbide | 12,53 |
| 01860202 | 2 | Carbide | 12,53 |
| 01860203 | 3 | Carbide | 12,53 |
| 01860307 | Wrench | - | - |

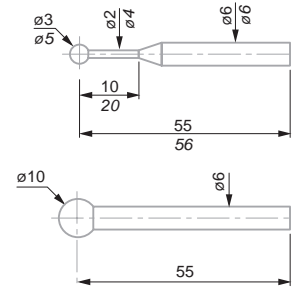

00760058, 00760059, 00760060



Packed suitable for transport

Barrel Shaped Inserts for Bores, Ø 6 mm Mounting Shaft, for FMS Probes

| No | Ø | Material | Thread |
|----------|-----|----------|-------------|
| 00760066 | 2,2 | Carbide | M3 to M16 |
| 00760067 | 4,5 | Carbide | M6 to M48 |
| 00760068 | 9,7 | Carbide | M12 to M150 |

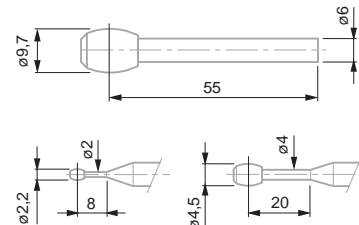

00760066, 00760067, 00760068



Packed suitable for transport

Disc Inserts for Grooves, Ø 6 mm Mounting Shaft, for FMS Probe

| No | Ø | Material | Disc thickness, mm |
|----------|-----|----------|--------------------|
| 00760074 | 4,5 | Carbide | 1 |
| 00760075 | 14 | Carbide | 2 |
| 00760076 | 19 | Carbide | 3 |

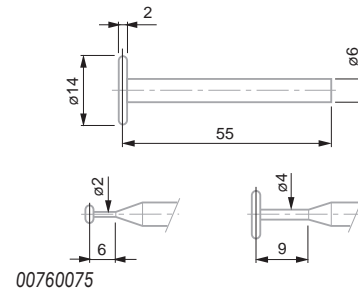

00760075

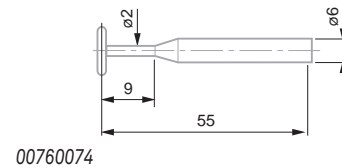

00760074



Transport packaging

Special Inserts, Ø 6 mm Mounting Shaft, for FMS Probes

| No | Ø | Material | L, mm |
|----------|---|----------|-------|
| 00760082 | 2 | Carbide | 55 |

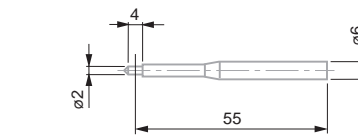

00760082



Packed suitable for transport

Universal Probe Holder with Ø 6 mm Mounting Shaft, for FMS Probes

| No | Thread | L, mm |
|----------|-----------------------|-------|
| 00760096 | M1,4 and M2,5 threads | 55 |

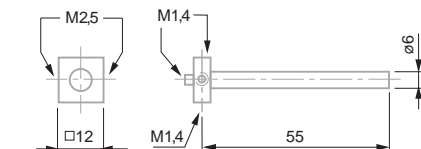

00760096



SPRINGS, PNEUMATIC ACTUATORS, HOLDERS, OFF-SET INSERTS, FOR FMS PROBE

Inserts with Offset Measuring Faces, for FMS Probes

| No | = | A | Drawing |
|----------|-------------------|---|---------|
| 02630047 | VBM offset insert | 1 | |
| 02630048 | VBN offset insert | 2 | |
| 02630049 | VBO offset insert | 3 | |
| 02630050 | VBP offset insert | 4 | |
| 02630051 | VBQ offset insert | 5 | |

Inserts with offset faces for FMS probes

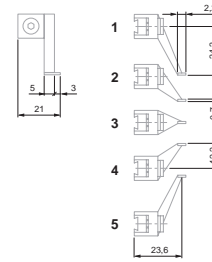

Packed suitable for transport

Fixed Holder, for FMS Probe

| No | = | ∅ | A | A | Number | Position |
|----------|------------------|---|---|------------|--------|----------|
| 02630042 | VBH fixed holder | 4 | 2 | Horizontal | | |
| 02630043 | VBJ fixed holder | 4 | 1 | Vertical | | |
| 02630045 | VBK fixed holder | 6 | 2 | Horizontal | | |
| 02630046 | VBL fixed holder | 6 | 1 | Vertical | | |

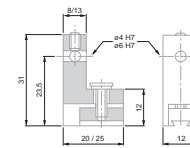

02630042
02630045

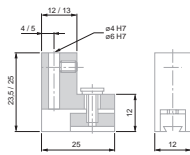

03230043
03230046



Packed suitable for transport

Holder with Fine Adjustment for FMS Probe

Helps greatly for setting a FMS probe.

Setting and locking screws remain accessible even when several probes are mounted side by side.

| No | mm | ∅ | A | A | Number | Position |
|----------|----|---|---|------------|--------|----------|
| 02630053 | 25 | 4 | 2 | Horizontal | | |
| 02630055 | 25 | 4 | 1 | Vertical | | |
| 02630052 | 25 | 6 | 2 | Horizontal | | |
| 02630054 | 25 | 6 | 1 | Vertical | | |

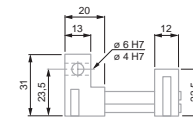

02630052
02630053

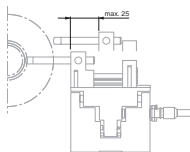

02630053



Holder width: 12 mm

Packed suitable for transport

Auxiliary Springs and Pneumatic Retraction Jack, for FMS Probe

| No | = | Hand | N |
|----------|----------------|-----------------|---|
| 03260440 | Pneumatic jack | 11 (for 4 bars) | |
| 03260441 | Spring element | 0,4 | |
| 03260442 | Spring element | 0,63 | |
| 03260443 | Spring element | 1,0 | |
| 03260444 | Spring element | 1,6 | |
| 03260445 | Spring element | 2,0 | |
| 03260446 | Spring element | 2,5 | |
| 03260447 | Spring element | 4,0 | |

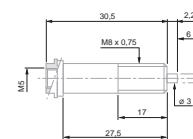

Pneumatic cylinder (jack) for FMS probe



Auxiliary spring element for FMS probe



All values given in the table for the measuring force equal nominal values at electrical zero; max. deviation $\pm 25\%$. Valid for probing movements executed horizontally as well as in static measuring.

Packed suitable for transport

Spring Set with Specific Measuring Force, for FMS Probe

| No | = | Hand | Measuring force, N |
|----------|-------------------|------|--------------------|
| 03260448 | Spring set red | 0,4 | |
| 03260449 | Spring set yellow | 0,63 | |
| 03260450 | Spring set green | 1,0 | |
| 03260451 | Spring set blue | 1,6 | |
| 03260452 | Spring set brown | 2,5 | |
| 03260453 | Spring set black | 4,0 | |

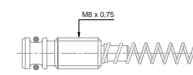

Spring set for measuring force for FMS probe



All values given in the table for the measuring force equal nominal values at electrical zero; max. deviation $\pm 25\%$. Valid for probing movements executed horizontally as well as in static measuring mode.

Packed suitable for transport



230 V 50 Hz



Packed suitable for transport

Maximum 20 probes type GT 22, GT 42 and GT 44, maximum force 0,63 N. Maximum 10 probes type GT 28 and GT 62, Maximum force 0,63 N.

(03260486) 3,5 kg

Electro-pneumatic Pump for Measuring Bolt Retraction

Electro-pneumatic vacuum pump, controlled by external switch (03260433): requires an automatic external command (e.g. instrument display).

| No | = | A | |
|----------|--|--|-------------------------------------|
| 03260432 | Electro-pneumatic vacuum pump with activation by connected foot switch | Electro-pneumatic vacuum pump. For the simultaneous retraction of a maximum number of 20 measuring bolts with a force up to 0,63 N | Activation by connected foot switch |
| 03260433 | Electro-pneumatic vacuum pump with activation by external control | Electro-pneumatic vacuum pump. For the simultaneous retraction of a maximum number of 20 measuring bolts with a force up to 0,63 N | Activation by external control |



Electro-pneumatic vacuum pump



Packed suitable for transport

Connectors for Electro-pneumatic Pump for Measuring Bolt Retraction

| No | = |
|----------|--|
| 03540403 | T-connector for tube $\varnothing 4,7 / \varnothing 2$ mm (03540405) |
| 03560000 | Straight connector, M4 thread for tube $\varnothing 4,7 / \varnothing 2$ mm (03540405) |
| 03560002 | Angled connector, M4 thread for tube $\varnothing 4,7 / \varnothing 2$ mm (03540405) |

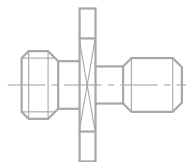

Straight connectors

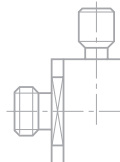

Angled connector

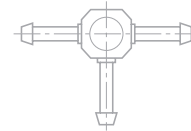

T-connector



Extension Cable for Probes, Lengths = 1 – 20m

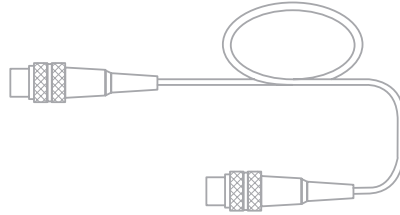

Cable extensions for TESA probes
DIN 453225, 5 pin connector



L, mm



It is recommended to calibrate equipment (probe + extension) connected together to ensure the highest accuracy.



Packed suitable for transport

No

=

Length, m (inch)

03240201

1m (3")

03240202

2m (6")

03240203

3m (9")

03240205

5m (32")

03240210

10m (49")

03240215

15m (65")

03240220

20m (16")



Optical Measurement



Software interface showing measurement data and graphs.

| Label | Feature type | Description | Actual | Deviation | LSL | USL | Nominal |
|-------|--------------|-------------|--------|-----------|--------|-------|---------|
| D01 | Diameter | Average | 26.504 | 0.024 | -0.100 | 0.100 | 26.500 |
| D02 | Diameter | Average | 26.531 | 0.381 | -0.100 | 0.100 | 26.800 |
| D03 | Diameter | Average | 26.885 | -0.815 | -0.100 | 0.100 | 26.500 |
| D04 | Diameter | Average | 25.176 | -0.824 | -0.100 | 0.100 | 25.500 |
| D05 | Diameter | Average | 23.475 | -0.825 | -0.100 | 0.100 | 23.700 |
| D06 | Diameter | Average | 13.762 | -0.068 | -0.100 | 0.100 | 13.500 |

A COMPLETE RANGE OF MACHINES FOR NON-CONTACT MEASUREMENT

Optical measurement addresses the growing need to inspect parts faster, in a more accurate and repeatable way. The TESA range meets these requirements whilst adapting to the morphology of the parts to inspect.

- The TESA-SCAN profile-measuring machines for measuring round parts.
- The TESA-VISIO digital vision systems for a wide variety of machined, milled, cut, molded or stamped parts.
- Classic measurement through TESA-SCOPE profile projectors for immediate measurement results.





Diameter: 0,5 s
Length: 0,5 s

24 VDC

Dimension max. parts:
Ø 100 x L 300 mm
Weight max. parts:
4 kg

< 80 %



Packaging

Inspection report with a declaration of conformity

Scope: see TESA-REFLEX Scan software

H840 x L 1000 x P435 mm H33 x L39,5 x P17 in

103 kg

10°C to 40°C

TESA-SCAN 52 REFLEX-Click

This model includes the ultimate power of all TESA-SCAN machines, offering high technological performances combined with unmatched ease of use and exceptional price/quality relationship.

Thanks to the added functionality for automatic recognition of the parts to be measured, the REFLEX-Click mode allows them to be quickly and reliably inspected with a single click. The colour coded classification of the measured values enables the analysis of the measurement results at a glance, rendering part inspection especially easy to execute.

Another unique function available in the REFLEX-Click mode is the ability to measure lengths and diameters speedily, making the machine ideally suited for use on the shop floor.

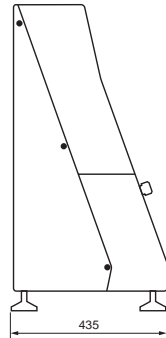
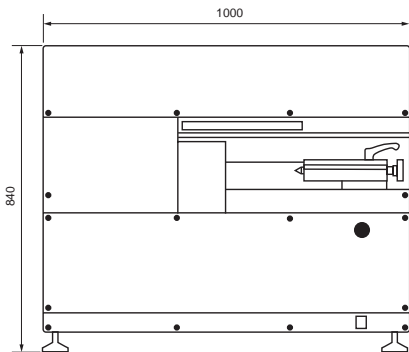

| | |
|-----------|-------------------------------|
| No | = |
| 02430090 | TESA-SCAN 52 fixed headstock |
| 02430091 | TESA-SCAN 52 rotary headstock |

| TESA-SCAN 52 REFLEX-Click | D | L | D | L | |
|---------------------------|-------------|----------------------------|----------------------------|---------------------------------------|--------------------------------------|
| | 0,5 ÷ 52 mm | 300 mm | 0.02 ÷ 2.0 in | 11.8 in | |
| | 0,0001 mm | 0,0005 mm | 0.000004 in | 0.00002 in | |
| | 20°C ± 1°C | (2 + D/100) µm (D = mm) | (5 + L/100) µm (L = mm) | (0.08 + D/100) / 1000 in (D in mm) | (0.2 + L/100) / 1000 in (L in mm) |
| | 2σ | 1 µm | 2,5 µm | 0.00004 in | 0.0001 in |

Performances are based on the results obtained from clean, ground components measured at 20°C. They may be affected by the component shape and surface finish.



TESA-SCAN 25

Measuring machine with rotating work including:

- 1 rotary headstock
- 1 tailstock
- 2 male centers TL02-0001
- Comes with computer, mouse, operating system Windows 7 screen TFT 21.5" Multilingual, U.S. keyboard software Pro-Measure with manual FDE application on CD.



- Diameter : 0,5 s
Length : 0,5 s
- 100/110-220/240
VAC 50/60 Hz
- Max. workpiece size
(D x L): 59 x 270 mm;
Max. workpiece
weight: 2 kg
- < 80 %
-
- Shipping packaging
- Inspection report
with a declaration
of conformity
- Performances:
see Pro-Measure
software
- H800 x L640
x P500 mm,
H32 x L25 x P20 in
- 67 kg, 148 lbs
- 10°C to 40°C

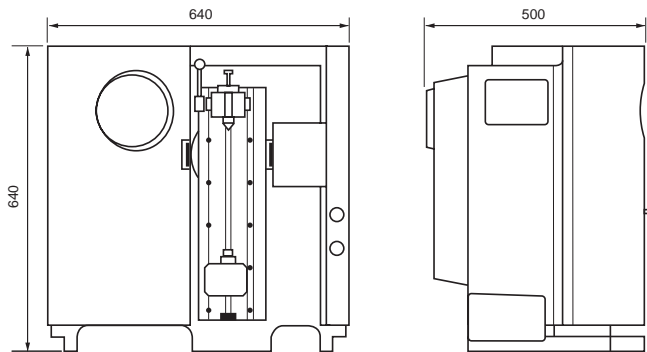

No **=**
02430000 TESA-SCAN 25

| TESA-SCAN 25 | D | L | D | L |
|--------------|--------------|------------------------------|-------------------------------------|---------------------------------|
| | 0,25 ÷ 25 mm | 200 mm | 0.01 ÷ 1 in | 8.0 in |
| | 0,0001 mm | 0,001 mm | 0.000004 in | 0.00004 in |
| | 20°C ± 1°C | (1,5 + D/100) µm (D = mm) | (0.06 + D/100)/ 1000 in (D = in) | (0.2 + L/100)/ 1000 (L = in) |
| | 2σ | 1 µm | 0.00004 in | 0.0001 in |

Performances are based on the results obtained from clean, ground components measured at 20°C. They may be affected by the component shape and surface finish.



Diameter : 0,5 s
Length : 0,5 s

100/110-220/240
VAC 50/60 Hz

Max. workpiece size
(D x L): 100 x 290
mm. Max. workpiece
weight: 4 kg.

< 80 %



Shipping packaging

Inspection report
with a declaration
of conformity

Performances:
see Pro-Measure
software

H1055 x L800
x P580 mm,
H41 x L32 x P23 in

130 kg, 290 lbs

10°C to 40°C

TESA-SCAN 50

Measuring machine with rotating work including:

- 1 rotary headstock
 - 1 tailstock
 - 2 male centers TL02-0002
- Comes with computer, mouse, operating system Windows 7 screen TFT 21.5"
Multilingual, U.S. keyboard, software Pro-Measure with manual FDE on CD.

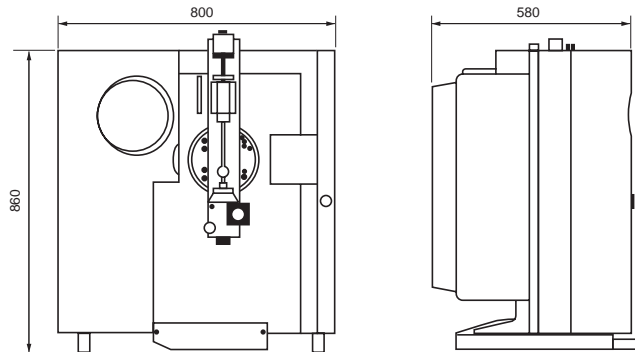

No **=**
02430010 TESA-SCAN 50

| TESA-SCAN 50 | D | L | D | L |
|--------------|-------------|----------------------------|-------------------------------------|---------------------------------|
| | 0,5 ÷ 50 mm | 275 mm | 0.02 ÷ 1.96 in | 10.8 in |
| | 0,0001 mm | 0,001 mm | 0.000004 in | 0.00004 in |
| | 20°C ± 1°C | (2 + D/100) µm (D = mm) | (0.08 + D/100)/ 1000 in (D = in) | (0.2 + L/100)/ 1000 (L = in) |
| | 2σ | 1 µm | 2,5 µm | 0.00004 in |

Performances are based on the results obtained from clean, ground components measured at 20°C. They may be affected by the component shape and surface finish.



TESA-SCAN 50 CE+

Measuring machine with workpiece rotation and tilt mechanism of the slide (30°) for thread measurement, base unit including:

- 1 rotary headstock
- 1 tailstock
- 2 male centers TL02-0002.
- Comes with computer with a mouse, 21.5" TFT screen Multilingual Windows 7 operating system, U.S. keyboard, Pro-Measure software with FDE implementation manual on CD.

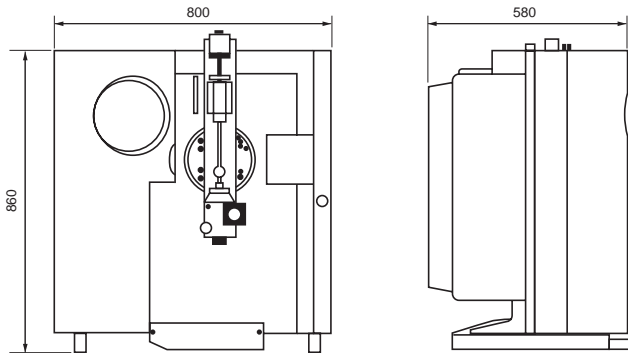
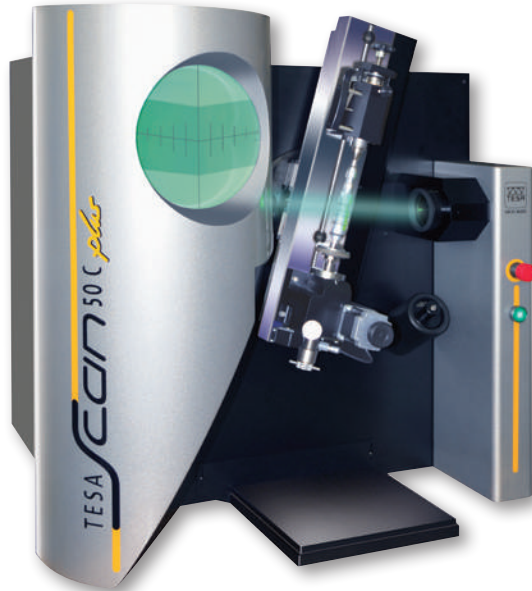

No **=**
02430030 TESA-SCAN 50CE+

| TESA-SCAN 50CE+ | D | L | D | L |
|--------------------------------|----------------------------|----------------------------|-------------------------------------|------------------------------------|
| | 0,5 ÷ 50 mm | 275 mm | 0.02 ÷ 1.96 in | 10.8 in |
| Tilting for thread measurement | Max. 30° | | | |
| | 0,0001 mm | 0,001 mm | 0.000004 in | 0.00004 in |
| 20°C ± 1°C | (2 + D/100) μm (D = mm) | (5 + L/100) μm (L = mm) | (0.08 + D/100)/ 1000 in (D = in) | (0.2 + L/100)/ 1000 in (L = in) |
| 2σ | 1 μm | 2,5 μm | 0.00004 in | 0.0001 in |

Performances are based on the results obtained from clean, ground components measured at 20°C. They may be affected by the component shape and surface finish.

- Diameter : 0,5 s
Length : 0,5 s
- 100/110-220/ 240
VAC 50/60 Hz
- Max. workpiece size
(D x L): 100 x 290
mm; Max. workpiece
weight: 4 kg
- < 80 %
-
- Shipping packaging
- Inspection report
with a declaration
of conformity
- Performances:
see Pro-Measure
software
- H1055 x L800
x P580 mm,
H41 x L32 x P23 in
- 140 kg, 310 lbs
- 10°C to 40°C





Diameter : 0,5 s
Length : 0,5 s

100/110-220/ 40
VAC 50-60 Hz

Max. workpiece size (D x L): 100 x 515 mm; Max. workpiece weight: 6 kg

< 80 %



Shipping packaging

Inspection report with a declaration of conformity

Performances: see Pro-Measure software

H1455 x L800 x P580 mm, H57 x L32 x P23 in

180 kg, 398 lbs

10°C to 4°C

TESA-SCAN 50+

Measuring machine with workpiece rotation and tilt mechanism of the slide (30°) for thread measurement, base unit including:

- 1 rotary headstock
- 1 tailstock
- 2 male centers TL02-0002
- Comes with computer with a mouse, 21.5" TFT screen Multilingual Windows 7 operating system, U.S. keyboard, Pro-Measure software with F-D-E implementation manual on CD.

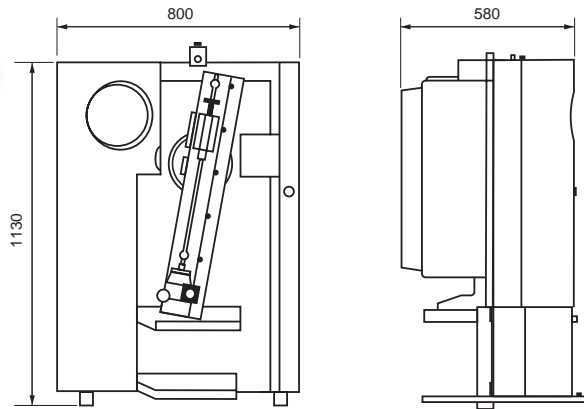
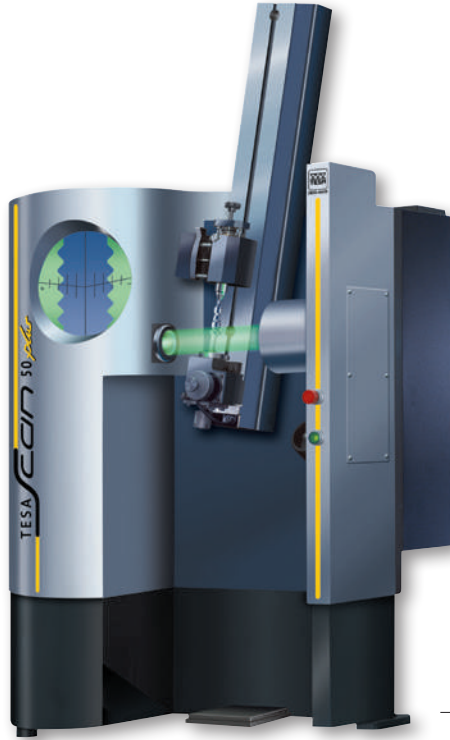

No =
02430040 TESA-SCAN 50+

| TESA-SCAN 50+ | D | L | D | L |
|--------------------------------|----------------------------|----------------------------|-------------------------------------|------------------------------------|
| | 0,5 ÷ 50 mm | 500 mm | 0.02 ÷ 1.96 in | 19.7 in |
| Tilting for thread measurement | Max. 15° | | | |
| | 0,0001 mm | 0,001 mm | 0.000004 in | 0.00004 in |
| 20°C ± 1°C | (2 + D/100) μm (D = mm) | (5 + L/100) μm (L = mm) | (0.08 + D/100)/ 1000 in (D = in) | (0.2 + L/100)/ 1000 in (L = in) |
| 2σ | 1 μm | 2,5 μm | 0.00004 in | 0.0001 in |

Performances are based on the results obtained from clean, ground components measured at 20°C. They may be affected by the component shape and surface finish.



TESA-SCAN 80/ 80+

Measurement center with protection cabin, part rotation and tilt mechanism slide (TESA-SCAN 80 +) base unit including:

- 1 rotary doll
- 1 tailstock
- 2 male centers TL02-0002
- Delivered with computer with a mouse, 7 Multilingual Windows operating system already installed, screen, keyboard, software Pro-Measure/Pro-Composer with F-D-E implementation manual on CD.

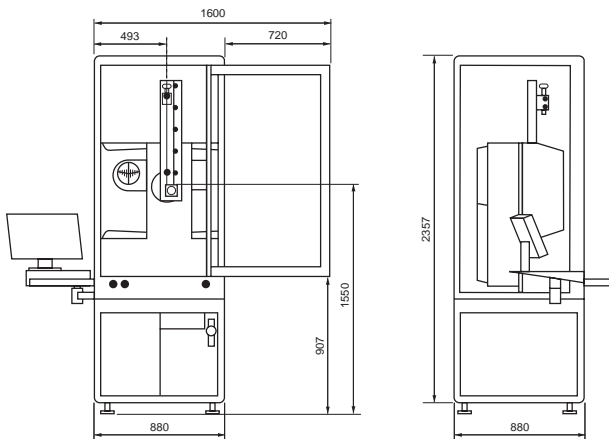

| No | = |
|----------|-----------------------------------|
| 02430050 | TESA-SCAN 80 |
| 02430060 | TESA-SCAN 80+ with slew mechanism |

- Diameter: 1 s
Length: 1 s
- 100/110-220/ 240 VAC 50/60 Hz
- Max. workpiece size (D x L): 100 x 515 mm; Max. workpiece weight: 6 kg
- < 80 %
-
- Shipping packaging
- Inspection report with a declaration of conformity
- Performances: see Pro-Measure software
- H 1500 x W750 x D 520 mm, H 60 x L 30 x P 20 in
- 250 kg (TESA-SCAN 80) 260 kg (TESA-SCAN 80+)
- 10°C à 35°C

| TESA-SCAN 80/ 80+ | D | L | D | L |
|--------------------------------|---------------------------|-------------------------|---------------------------------|---------------------------------|
| | 0,5 ± 80 mm | 500 mm | 0.02 ÷ 3.15 in | 19.7 in |
| Tilting for thread measurement | Max. 10° (TESA-SCAN 80+) | | | |
| | 0,0001 mm | 0,001 mm | 0.000004 in | 0.00004 in |
| Max. tolerated error Ø < 30 mm | (1,5 + D/100) µm (D = mm) | (7 + L/100) µm (L = mm) | (0.06 + D/100)/1000 in (D = in) | (0.28 + L/100)/1000 in (L = in) |
| Ø > 30 mm (20°C ± 1°C) | (2 + D/100) µm (D = mm) | (8 + L/100) µm (L = mm) | (0.08 + D/100)/1000 in (D = in) | (0.35 + L/100)/1000 in (L = in) |
| 2σ | 0,001 mm | 0,003 mm | 0.00004 in | 0.00012 in |

Performances are based on the results obtained from clean, ground components measured at 20°C. They may be affected by the component shape and surface finish.



Fixturing Systems

Full range of standard fixturings, morse 1 (TESA-SCAN 25) and Morse 2 (TESA-SCAN 50, 52, 80).

| No | | | Morse taper 1 | Morse taper 2 | |
|-----------|--|--|----------------------------|----------------------------|---|
| TL01-0002 | Center adapter with a $\varnothing 6$ mm coupling bore | | ● | - | - |
| TL01-0003 | 2-jaw gripper | | ● | ● Requires TL01-0027 | External clamping for manual use |
| TL01-0004 | 2-jaw gripper | | ● | ● Requires TL01-0027 | External clamping for use with air pressure |
| TL01-0005 | Raising blocks, in pairs | | For TL01-0003 TL01-0004 | For TL01-0003 TL01-0004 | For external jaws H = 18 |
| TL01-0006 | Raising blocks, in pairs | | For TL01-0003 TL01-0004 | For TL01-0003 TL01-0004 | For external jaws H = 22 |
| TL01-0007 | 2-jaw chuck | | ● | ● Requires TL01-0027 | Internal clamping for manual use |
| TL01-0008 | 2-jaw chuck | | ● | ● Requires TL01-0027 | Internal clamping for use with air pressure |
| TL01-0009 | External jaws, in pairs | | For TL01-0003 TL01-0004 | For TL01-0003 TL01-0004 | $0 \div 6$ mm, T = 1.5 |
| TL01-0010 | External jaws, in pairs | | For TL01-0003 TL01-0004 | For TL01-0003 TL01-0004 | $0 \div 6$ mm, T = 3 |
| TL01-0011 | External jaws, in pairs | | For TL01-0003 TL01-0004 | For TL01-0003 TL01-0004 | $6 \div 12$ mm, T = 3 |
| TL01-0012 | External jaws, in pairs | | For TL01-0003 TL01-0004 | For TL01-0003 TL01-0004 | $12 \div 18$ mm, T = 6 |
| TL01-0013 | External jaws, in pairs | | For TL01-0003 TL01-0004 | For TL01-0003 TL01-0004 | $18 \div 24$ mm, T = 9 |





| No | = | | Morse taper 1 | Morse taper 2 | |
|-----------|---|--|----------------------------|----------------------------|--|
| TL01-0015 | Internal jaws, in pairs | | For TL01-0007 TL01-0008 | For TL01-0007 TL01-0008 | D = 4 ÷ 5 mm H = 6,6 mm |
| TL01-0016 | Internal jaws, in pairs | | For TL01-0007 TL01-0008 | For TL01-0007 TL01-0008 | D = 5 ÷ 6 mm H = 8,6 mm |
| TL01-0017 | Internal jaws, in pairs | | For TL01-0007 TL01-0008 | For TL01-0007 TL01-0008 | D = 6 ÷ 8 mm H = 11,5 mm |
| TL01-0018 | Internal jaws, in pairs | | For TL01-0007 TL01-0008 | For TL01-0007 TL01-0008 | D = 8 ÷ 11 mm H = 17,5 mm |
| TL01-0019 | Internal jaws, in pairs | | For TL01-0007 TL01-0008 | For TL01-0007 TL01-0008 | D = 11 ÷ 15 mm H = 20 mm |
| TL01-0020 | Internal jaws, in pairs | | For TL01-0007 TL01-0008 | For TL01-0007 TL01-0008 | D = 15 ÷ 19 mm H = 20,2 mm |
| TL01-0021 | Set of external jaws, in pars | | For TL01-0003 TL01-0004 | For TL01-0003 TL01-0004 | Set of jaws including: TL01-0009 TL01-0010 TL01-0011 TL01-0012 TL01-0013 |
| TL01-0022 | Set of interna jaws, in pairs | | For TL01-0007 TL01-0008 | For TL01-0007 TL01-0008 | Set of jaws including: TL01-0015 TL01-0016 TL01-0017 TL01-0018 TL01-0019 TL01-0020 |
| TL01-0026 | Centre adapter with a 6 mm dia. coupling bore | | - | ● | - |
| TL01-0027 | Reduction sleeve, Morese 2 to 1 | | - | ● | - |



| No | | | Morse taper 1 | Morse taper 2 | |
|-----------|----------------------------------|--|--|--|--|
| TL01-0038 | Exteranl jaws, in pairs | | For TL01-0003 TL01-0004 | For TL01-0003 TL01-0004 | 0 ÷ 6 mm, T = 6 |
| TL01-0039 | Exteranl jaws, in pairs | | For TL01-0003 TL01-0004 | For TL01-0003 TL01-0004 | 0 ÷ 6 mm, T = 15 |
| TL01-0040 | Exteranl jaws, in pairs | | For TL01-0003 TL01-0004 | For TL01-0003 TL01-0004 | 6 ÷ 12 mm, T = 15 |
| TL02-0001 | Extra male centre, 10 mm | | ● | – | 2 items provided with TESA-SCAN 25 as standard |
| TL02-0002 | Extra male centre, 17 mm | | – | ● | 2 items provided ith TESA-SCAN 50, 52 and 80 as standard |
| TL02-0003 | Drive centre | | ● | – | Diamond coated tip 10 mm |
| TL02-0016 | Rotation centre with a B12 taper | | ● | – | Suitable for sleeves Z173-0922/0923 |
| TL02-0017 | Rotation centre, Morse 2 | | – | ● | – |
| TL02-0018 | Rotation centre with a B12 taper | | – | ● | – |
| TL02-0019 | Rotation centre, Morse 1 | | ● | – | – |
| TL02-0021 | Rotation centre, Morse 2 | | – | ● | – |
| Z173-0908 | Vertical support | | For TL01-0003 TL01-0004 TL01-0007 TL01-0008 | For TL01-0003 TL01-0004 TL01-0007 TL01-0008 | Ensures stable positioning for mounting jaws |
| Z173-0920 | Female centre, Ø 10 mm | | ● Requires TL01-0002 | ● Requires TL01-0026 | – |
| Z173-0921 | Female centre, Ø 20 mm | | ● Requires TL01-0002 | ● Requires TL01-0026 | – |
| Z173-0922 | Female centre, Ø 10 mm | | ● For TL02-0016 | – | B12 interior taper |
| Z173-0923 | Female centre, Ø 20 mm | | ● For TL02-0016 | – | B12 interior taper |

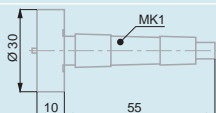
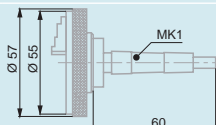
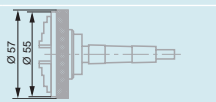
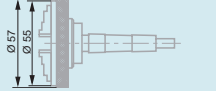
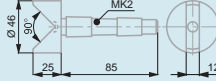
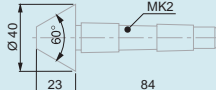
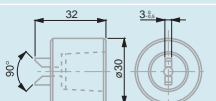

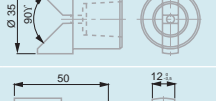
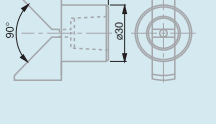
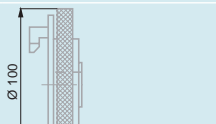
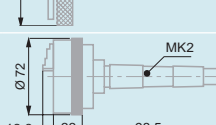
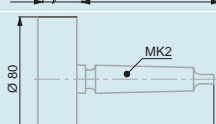
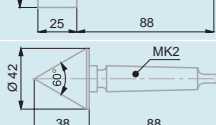
| No | | | Morse taper 1 | Morse taper 2 | |
|-----------|---|---|---------------|----------------------------|--|
| Z173-0961 | Platten, Ø 30 mm |  | ● | - | - |
| Z173-2020 | 3-jaw chuck |  | ● | ● Requires TL01-0027 | Clamping capacity: Outside 1 ÷ 15 mm, Inside 11 ÷ 26 mm |
| Z173-2024 | 6-jaw chuck |  | - | ● | - |
| Z173-2025 | 6-jaw chuck |  | ● | - | - |
| Z178-0607 | Female centre |  | - | ● | Ø 40 mm |
| Z178-0610 | Male centre, Ø 15 ÷ 40 mm |  | - | ● | - |
| Z178-0940 | Female centre with a B12 internal taper |  | - | ● Requires TL02-0018 | Ø 10 mm |
| Z178-0941 | Female centre with a B12 internal taper |  | - | ● Requires TL02-0018 | Ø 30 mm |
| Z178-0942 | Female centre with a B12 internal taper |  | - | ● Requires TL02-0018 | Ø 45 mm |
| Z178-2009 | Drive mechanism |  | - | ● | Used to drive components between fixed centres. Directly fitted on the headstock |
| Z178-2020 | 3-jaw chuck. 2 ÷ 50 mm |  | - | ● | Clamping capacity: Outside 2 ÷ 50 mm, Inside 23 ÷ 50 mm |
| Z178-2025 | Platten, Ø 80 mm |  | - | ● | - |
| Z178-2026 | Drive centre |  | - | ● | Diamond coated tip |
| Z178-3028 | Drive centre, Ø 42 mm max. |  | - | ● | - |





SOFTWARE FOR PROFILE MEASURING MACHINES

Equipped with TESA-REFLEX Scan software, the TESA-SCAN 52 is robust and easy to use, and therefore perfect for use in workshops. Close at hand to operators, it replaces conventional measuring systems, including multigauging systems, offering unmatched flexibility and significant time savings.

Featuring an ergonomic interface and offering a large number of dimensions that can be measured, Pro-Measure retains the philosophy of TESA-REFLEX Scan software whilst providing greater capacity for the most advanced of measuring applications.

TESA-REFLEX Scan Software

Key Features :

- Automatic measurement of lengths and diameters using the REFLEX-Click function.
- Automatic recognition of the parts being measured or the programmes used.
- Intelligent detection of the relevant measurement zones.
- Management of the operator and programming modes.
- Value storage.
- Dynamic displaying of the measurement results.
- Flexible reporting.

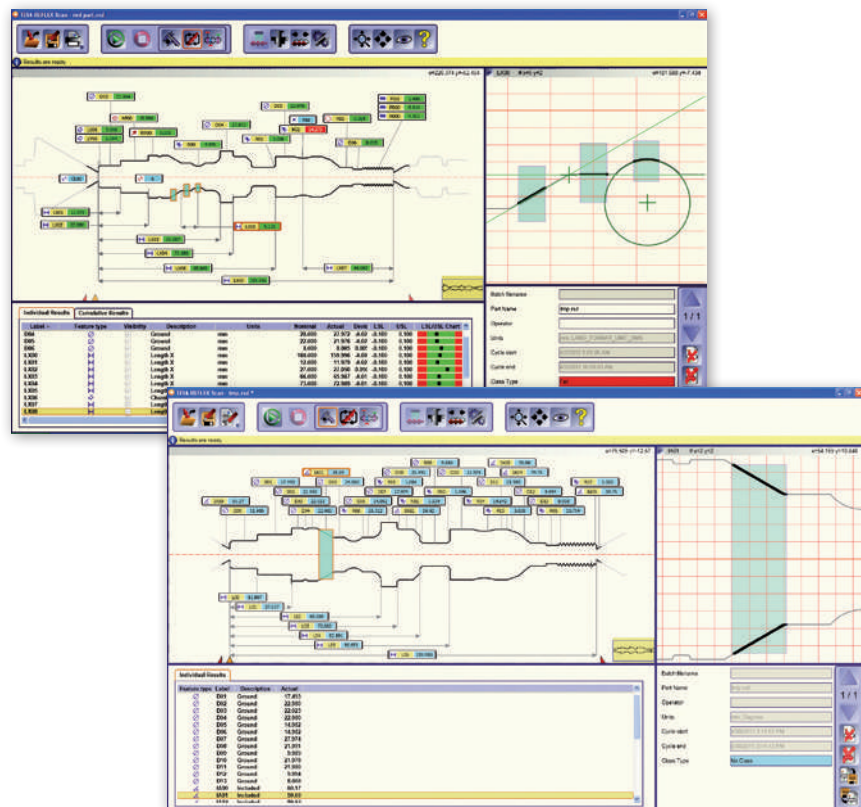

02460100

TESA-REFLEX Scan



Pro-Measure Software

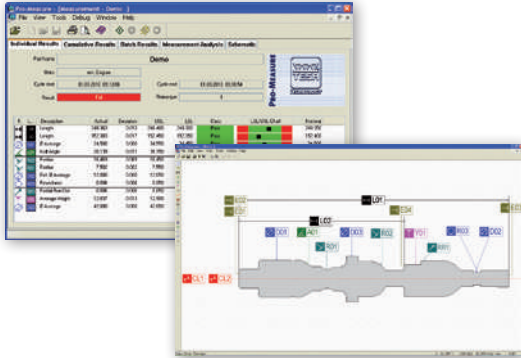

Key Features:

- Rapid creation of programmes.
- Wide variety of measuring functions.
- Statistical follow up for optimum monitoring of the manufacturing process.
- Control of access for different user levels.
- Flexible reporting.



Taper threads

- Pitch
- Flank angle
- Included angle
- Gauge length
- Usable thread length
- Pitch diameter
- Major diameter

| | |
|---|---|
|  |  |
| 02460011 | Pro-Measure |
| 02460076 | Option Pro-Measure for off-line programming |

Conicity on diameter Thread and worm thread measurement With mechanical slewing

Main Features:

Parallel threads

- Major diameter
- Flank diameter
- Pitch
- Minor diameter
- Flank angle
- Root radius
- Crest radius
- Circularity
- Lead error

Taper threads

- Pitch diameter
- Major diameter
- Minor diameter
- Taper
- Crest diameter

Double-threads, parallel

- Major and minor diameters
- Half pitch
- Flank angle
- Crest radius
- Root radius

Worm threads (on request)

- Pitch
- Major and minor diameters
- Over Wire diameter
- Tooth thickness
- Pressure angle
- Addendum
- Dedendum
- Thread depth
- Runout

• Ball screws (on request)

- Pitch
- Lead error
- Over wire diameter

Static measurement

Diameters, lengths, intersection points, gauge diameters, radii, angles etc. 2D workpiece alignment – Creation of a workpiece axis based on two datum diameters.

Dynamic measurement

Concentricity – Parallel or interrupted diameters, tapers, parallel thread profiles or on maxi form.

Runout – Plain or interrupted diameters.

Diameters with rotation, ovality, max, min and average diameters of plain or interrupted diameters.

Hexagonal – Across-flats, symmetry of flats to axis, max. dimension across corners.

Section analysis with rotation – Longest and shortest section of radii, angular location.

3D workpiece alignment – Creation of a workpiece axis with reference to plain diameters or thread lengths.

Thread measurement – With no mechanical slewing

Main Features:

Parallel, vee-shaped threads

- Major diameter
- Flank diameter
- Flank angle
- Pitch



TESA-VISIO 200 GL



MPEX, Y* (EX, EY)
= (2 + 10 L/1000)
µm MPEXY* (EXY)
= (2,9 + 10 L/1000)
µm MPEZ** (EZ) =
(2,9 + 10 L/1000) µm
* L in mm
** Mechanical

precision with no
displacement in X-Y



Opto-electronic
measuring systems
with incremental
glass scales, resolu-
tion to 0,05 µm



Rigid granite
structure



100 ÷ 240 VAC
± 10 %; 50 ÷ 60 Hz



Max. load capacity:
10 kg



10°C to 40°C



80 %, non-condensing



Shipping packaging
(W x D x H): 800 x
1200 x 1100 mm



Calibration
certificate



Declaration
of conformity



Manual



Measuring volume
(X/Y/Z): 200 x 100
x 150 mm



Table surface (X/Y):
400 x 280 mm



Delivered fully
assembled



98 kg



Display resolution:
0,001 mm



20°C ± 1°C

Optics

Available with a manual indexable zoom or a motorised zoom for greater comfort. Also provided with a CCD colour camera.

Light illuminations

All light sources are fitted with LEDs producing a cold light, also long-lasting.

- Diascopic illumination for checking profiles as well as for transparency-based measurements.
- Ringlight (4 x 90°) for millings, bores, chamfers and round edges.
- Coaxial light for blind bores and cylindrical parts.
- Each light source can be set separately over the software.

Swiss mechanics

Granite structure to ensure the rigidity and stability required for any high-precision measuring system.



| No | = | | 0/0 | ✳ | ✳ |
|----------|-------------------------------|----------------------------|---|---------|---------|
| 06830401 | TESA-VISIO 200 manual zoom | 200 x 100 x 150 mm (X/Y/Z) | MPE _{x,y} (Ex, Ey) = (2 + 10L*/1000) MPE _{xy} (Exy) = (2,9 + 10L*/1000) MPE _z (Ez) = (3,9 + 10L*/1000) *L = mm | Manuals | 4 x 90° |
| 06830428 | TESA-VISIO 200 motorised zoom | 200 x 100 x 150 mm (X/Y/Z) | MPE _{x,y} (Ex, Ey) = (2 + 10L*/1000) MPE _{xy} (Exy) = (2,9 + 10L*/1000) MPE _z (Ez) = (3,9 + 10L*/1000) *L = mm | Manuals | 4 x 90° |

OPTIONAL ACCESSORIES:

| | |
|----------|----------------------------------|
| 06860030 | Lens 0,5x |
| 06860031 | Lens 0,75x |
| 06860032 | Lens 1,5x |
| 06860033 | Lens 2x |
| 06860145 | Collimated light |
| 06860186 | Foot pedal for TESA-VISIO manual |
| 06860187 | TESA-REFLEX Vista Compare |
| 06860400 | Base kit |
| 06860401 | Advanced kit |
| 06869122 | PLASTIFORM Full case |

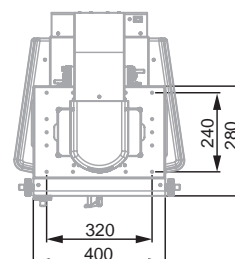
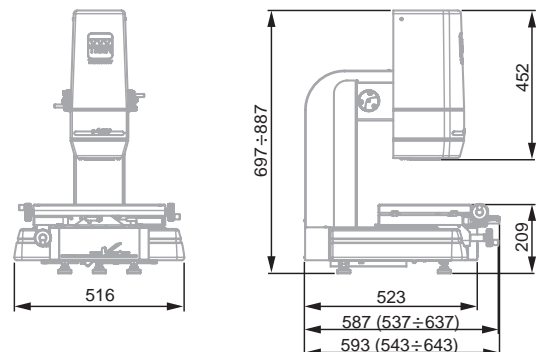

TESA-VISIO 300 GL MANUAL



Key features:

Optical All machines are equipped as standard with a motorized zoom and a color camera.

Lighting

- All machines are equipped with light sources light-emitting diodes (long life. Cold light).
- A lighting diascopic useful for profile pictures and measurement through.
- A light two annular segments (4 x 90 + 8° x 45°) useful for illuminating surface millings, holes, chamfers, rounded edges.
- A useful coaxial light for blind holes and cylindrical parts. Each light is independently adjustable via software.

Swiss Design Each machine consists of a granite structure ensuring rigidity and stability required by any system of measurement precision.

| No | = | | 0± | ✳ | ✳ |
|----------|---------------------------------------|-------------------------------|--|---------|-------------------|
| 06830602 | TESA-VISIO 300 GL man. 12X zoom | 300 x 200 x 150 mm (X/Y/Z) | MPE _{x,y} (Ex, Ey) = (2 + 4L*/1000) MPE _{xy} (Exy) = (2,5 + 4L*/1000) MPE _z (Ez) = (3,9 + 5L*/1000) *L = mm | Manuals | 4 x 90° + 8 x 45° |
| 06830601 | TESA-VISIO 300M GL man. 6,5 x zoom | 300 x 200 x 150 mm (X/Y/Z) | MPE _{x,y} (Ex, Ey) = (2 + 4L*/1000) MPE _{xy} (Exy) = (2,5 + 4L*/1000) MPE _z (Ez) = (3,9 + 5L*/1000) *L = mm | Manuals | 4 x 90° + 8 x 45° |

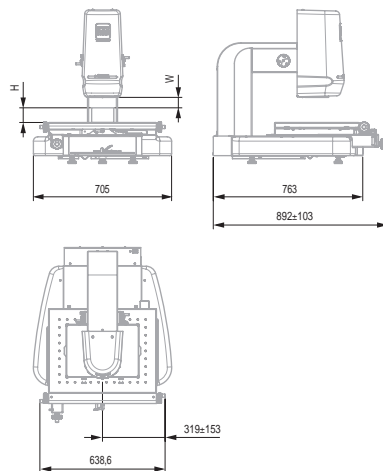

OPTIONAL ACCESSORIES:

| | |
|----------|----------------------------------|
| 06860030 | Lens 0,5x |
| 06860031 | Lens 0,75x |
| 06860032 | Lens 1,5x |
| 06860033 | Lens 2x |
| 06860145 | Collimated light |
| 06860186 | Foot pedal for TESA-VISIO manual |
| 06860187 | TESA-REFLEX Vista Compare |
| 06860287 | 0,5x lens |
| 06860288 | 0,75x lens |
| 06860289 | 1,5x lens |
| 06860290 | 2x lens |
| 06860400 | Base kit |
| 06860401 | Advanced kit |
| 06869122 | PLASTIFORM Full case |



MPE_{x,y}* (EX, EY) = (2,0 + 4 L/1000) μm
MPE_{xy}* (EXY) = (2,5 + 4 L/1000) μm
MPE_z* (EZ) = (3,9 + 5 L/1000) μm * L en mm

Systems opto - electronic with incremental scales, resolution 0,05 μm

Rigid granite structure

100 ± 240 VAC ± 10 %; 50 ÷ 60 Hz

Load capacity 20 kg

10° C to 40° C

80 %, no condensation



Transport Packaging (W x D x H): 1630 x 1140 x 1360 mm

Calibration certificate

Déclaration of conformity

Measurement volume(X/Y/Z): 300 x 200 x 150 mm

Surface table (X/Y): 550 x 430 mm

Shipped assembled

170 kg

Resolution: 0,001 mm

20° C ± 1° C



OPTICAL

Additional lenses for greater magnification range.

Additional Lenses for 6,5 Zoom

Mounts on TESA-VISIO 200 and 300 GL equipped with 6,5x lens.



No

=

| | |
|----------|------------|
| 06860030 | Lens 0,5x |
| 06860031 | Lens 0,75x |
| 06860032 | Lens 1,5x |
| 06860033 | Lens 2x |

Indicative values for a 20-inch monitor with a 6,5x magnification (0,7x to 4,5x), also with additional lens

| No | 06860030 | 06860031 | - | 06860032 | 06860033 |
|--------------------------|------------|--------------|-----------|-----------|-----------|
| Lenses | 0,5x | 0,75x | -(1x) | 1,5x | 2x |
| Magnifications | 15 ÷ 85 | 22,5 ÷ 127,5 | 30 ÷ 170 | 45 ÷ 255 | 60 ÷ 340 |
| Work distance (W) in mm | 175 | 110 | 90 | 50 | 35 |
| Max. height (H) in mm | 0 ÷ 45 | 0 ÷ 110 | 0 ÷ 130 | 0 ÷ 170 | 0 ÷ 185 |
| Max. field of view in mm | 12,8 x 9,6 | 8,5 x 6,4 | 6,4 x 4,8 | 4,2 x 3,2 | 3,2 x 2,4 |
| Min. field of view in mm | 2,2 x 1,6 | 1,5 x 1,1 | 1,1 x 0,8 | 0,7 x 0,5 | 0,5 x 0,4 |

Additional Lenses for 12x Zoom

Mounts on TESA-VISIO 300 GL equipped with x12



No

=

| | |
|----------|------------|
| 06860287 | 0,5x lens |
| 06860288 | 0,75x lens |
| 06860289 | 1,5x lens |
| 06860290 | 2x lens |

Indicative values for a 20-inch monitor with a 12x (0,58x to 7x), also with additional lens

| No | 06860287 | 06860288 | - | 06860289 | 06860290 |
|--------------------------|-----------|--------------|-----------|-----------|-----------|
| Lenses | 0,5x | 0,75x | -(1x) | 1,5x | 2x |
| Magnifications | 13 ÷ 130 | 19,5 ÷ 181,5 | 26 ÷ 260 | 39 ÷ 390 | 52 ÷ 520 |
| Workd distance (W) in mm | 165 | 105 | 85 | 50 | 30 |
| Max. height (H) in mm | 0 ÷ 55 | 0 ÷ 115 | 0 ÷ 135 | 0 ÷ 170 | 0 ÷ 190 |
| Max. field of view in mm | 14,7 x 11 | 9,8 x 7,3 | 7,3 x 5,5 | 4,9 x 3,7 | 3,6 x 2,7 |
| Min. field of view in mm | 1,4 x 1,1 | 0,9 x 0,7 | 0,7 x 0,5 | 0,4 x 0,3 | 0,3 x 0,2 |



ILLUMINATION

To make parallel the diascopic light and avoid reflection phenomena when measuring parts cylindriques

Diascopic Parallel Light

| | |
|---|---|
|  |  |
| 06860145 | Collimated light |





CLAMPING KITS

Two kits to choose from for attachment suitable for all room types:

- Basic
- Advanced

Fixing Kit for TESA VISIO

Workholding kits

| | |
|---|---|
|  |  |
| 06860400 | Base kit |
| 06860401 | Advanced kit |

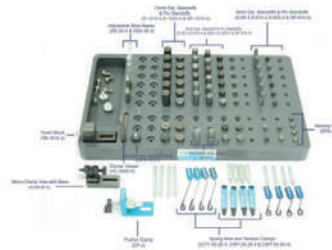



ADDITIONAL ACCESSORIES

Ground control for entering points for TESA-VISIO manual

Foot Switch for Data Capture

For manual TESA-VISIO

| | |
|---|---|
|  |  |
| 06860186 | Foot pedal for TESA-VISIO manual |



SOFTWARE FOR VISION SYSTEMS

– TESA-REFLEX Vista for manual TESA-VISIO

TESA-REFLEX Vista Software

For manual vision machines

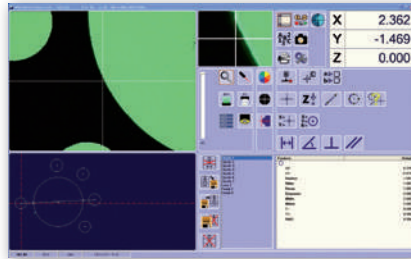

TESA-REFLEX Vista Compare Option

Visual comparison of the component with its CAD model (option within the TESA-REFLEX) software)

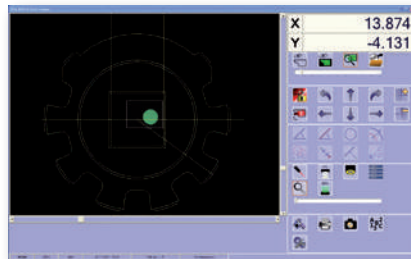

TESA-SCOPE VERTICAL MODEL





















TESA-SCOPE II 300V probes are available with a measurement range of 200 x 100 mm while the "Plus" version has a field measuring 300 x 150 mm.

TESA-SCOPE II 300V and 300V Plus





Perfectly adapted to the control of parts and other planar surface of the micro-mechanical components .

- Profile projectors vertical light.
- 360° rotating screen frosted glass . Ø 300 mm. Etched reticles 30°, 60° and 90°, equipped with four fixed - diagrams .
- Rotate the screen with sexagesimal and decimal display resolution in minutes - Reset ABS / INC .
- Profile illumination with green filter included . Increases contrast , facilitates measurement and decreases the influence of the operator.
- Surface illumination with fiber optic adjustable for optimal projection of the image.
- "Save Lamp" system . Automatic stop lamp when the projector is not used for several minutes (life bulbs 5 times on average).
- Quick-change goals , bayonet .
- Coordinate Measuring Table, equipped with an optoelectronic rule, resolution 0,001 mm .
 Measuring range:
 - 200 x 100 mm
 - X axis with a clutch for a quick trip.
 - Move the X axis for right and left handed.
 - Maximum load of 10 kg.
- Lateral support for documents.



-  Field measuring 200 x 100 mm (X / Y)
-  Résolution 0,001 mm
-  Measuring system with incremental scales, opto-electronics, resolution 0,001 mm.
-  In a coordinate direction (4,5 + L/40) ≤ 8 µm (L = mm) big table (5 + L/20) µm (L = mm)
-  Optical precision ± 0,05 % in lighting profile, ± 0,10 % in surface lighting.
-  Surface 350 x 210 mm (X/Y)
-  Stable and rigid steel structure Table in anodized aluminum
-  Load capacity 10 kg
Lighting Profile: lamp 24V 150W with thermal
Lighting filter surface: adjustable fiber optic lamp 24V 200W with thermal filter
-  115 ÷ 230 VAC ± 10 %; 50 ÷ 60 Hz
-  20°C ± 1°C
-  10°C to 40°C
-  80 %, without condensation
-  IP40
-  IEC 61010
EN 60204
EN 61326-1
-  110 kg
-  Comes fully assembled, objectives to be ordered separately.
-  Shipping Packaging
-  Serial number
-  Declaration of conformity
-  TESA measuring report



| | | Base | Measuring Table | | | Digital Readout / Control Panel | | |
|---|---|------|--------------------------|--------------------------|---|---------------------------------|-------|--------|
| | | | X = 200 mm Y = 100 mm | X = 300 mm Y = 150 mm | | TS100 | TS300 | TS300E |
|  |  | | | | | | | |
| TESA-SCOPE II 300V | 06830041 | ● | ● | - | ● | - | - | |
| TESA-SCOPE II 300V | 06830042 | ● | ● | - | - | ● | - | |
| TESA-SCOPE II 300V | 06830043 | ● | ● | - | - | - | ● | |
|  |  | | | | | | | |
| TESA-SCOPE II 300V Plus | 06830044 | ● | - | ● | ● | - | - | |
| TESA-SCOPE II 300V Plus | 06830045 | ● | - | ● | - | ● | - | |
| TESA-SCOPE II 300V Plus | 06830046 | ● | - | ● | - | - | ● | |

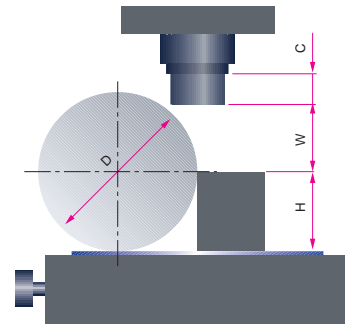
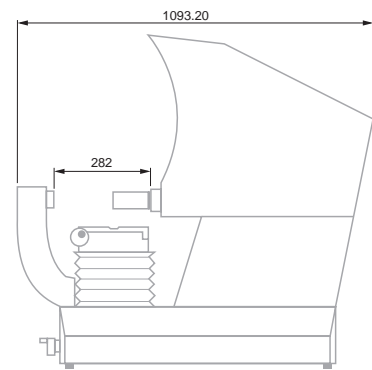
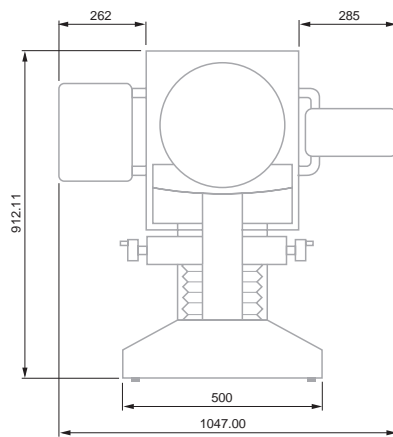

Telecentric Lenses for TESA-SCOPE 300V and 300V Plus

For TESA-SCOPE II 300V and 300V Plus



| No | = | ✳ | ✳ | ✳ | ✳ | ✳ |
|----------|---------------------|------------------|--------------------------|------------------------|--------------------------|--------------------------|
| | | Object-field, mm | Working distance (W), mm | Maximum height (H), mm | Masimum diameter (D), mm | Objective lenght (C), mm |
| 06860001 | Lens 300V - 10x | 30 | 80 | 83 | 166 | 37 |
| 06860002 | Lens 300V - 20x | 15 | 82 | 83 | 166 | 35 |
| 06860003 | Lens 300V - 25x | 12 | 70 | 83 | 166 | 47 |
| 06860004 | Lens 300V - 31, 25x | 9,6 | 56 | 83 | 166 | 61 |
| 06860005 | Lens 300V - 50x | 6 | 53 | 83 | 166 | 64 |
| 06860006 | Lens 300V - 100x | 3 | 43 | 83 | 166 | 74 |

Accessories for TESA-SCOPE Vertical Model

For TESA-SCOPE II 300V and 300V Plus

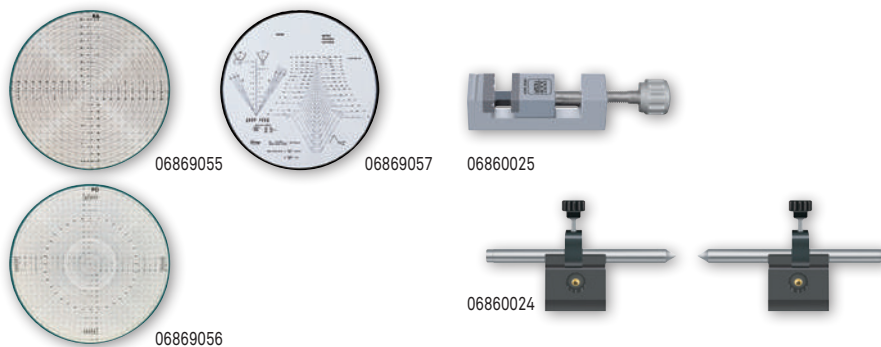

| No | = |
|----------|---|
| 06860015 | Glass window 200 X 100 mm |
| 06860016 | Glass window 150 mm x 300 mm |
| 06860017 | 300 mm diameter viewing screen with 4 overlay chart clips |
| 06860020 | Profile lamp, 24 Volts - 150 Watts |
| 06860021 | Surface lamp, 24 Volts - 200 Watts |
| 06860060 | Ø 90 mm rotary table, for table 200 x 100 mm |
| 06860061 | Ø 90 mm rotary table, for table 300 x 150 mm |
| 06860022 | Ø 150 mm rotary table, for table 200 x 100 mm |
| 06860029 | Ø 150 mm rotary table, for table 300 x 150 mm |
| 06860024 | V-blocks and centres |
| 06860025 | Vise stage |
| 06860027 | TESA practice piece |
| 06869055 | Measuring foil, type RA, for radius, circle, bending radius |
| 06869056 | Measuring foil, type PO, for radius and angle |
| 06869057 | Measuring foil, type M" ISO, for thread measurement |
| 06769007 | Set of prism |

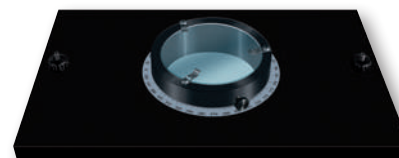

06860017



06860060



06860022 / 29



TESA-SCOPE HORIZONTAL MODEL





















TESA-SCOPE II 355H are available with a measurement range of 200 x 100 mm while the "Plus" version has a field measuring 200 x 100mm.

TESA-SCOPE II 355H and 355H Plus





Are ideally suited for control rooms Revolution

- Profile projectors horizontal light.
 - 360° rotating screen frosted glass , Ø 355 mm. Etched reticles 30°, 60° and 90°, equipped with four fixed - diagrams .
 - Rotate the screen with sexagesimal and decimal display resolution in minutes
 - Reset ABS / INC
 - Profile illumination with green filter included . Increases contrast , facilitates measurement and decreases the influence of the operator.
 - Surface illumination with fiber optic adjustable for optimal projection of the image.
 - Save Lamp System. Automatic shutdown of lamps after several minutes of non- use of the projector (life bulbs multiplied by 5 average)
 - Quick-change goals , bayonet .
 - Coordinate Table equipped with opto -electronics rule, resolution 0,001 mm.
- Measuring range:
- 200 x 100 mm.
 - X axis with a clutch system for a quick trip.
 - Moving in the direction of X coordinate for right and left handed .
 - Maximum load of 10 kg , without affecting accuracy.
- Lateral support for documents.



-  Field measuring 200 x 100 mm (X / Y)
-  Resolution 0,001 mm
-  Measuring system with incremental scales, opto-electronics, resolution 0,001 mm.
-  In a coordinate direction (4,5 + L/40) µm ≤ 8 (L in mm) µm large table (5 + L/20) µm (L in mm)
-  Optical precision ± 0,05 % lighting profile, ± 0,10 % in surface lighting.
-  Surface table 350 x 100 mm (X / Y)
-  Stable and rigid steel structure Table in anodized aluminum
-  Capacity Load 10 kg Lighting Profile: Lamp 24 V, 150 W with thermal filter. Surface lighting: directional fiber optic lamp 24 V, 200 Watts with thermal filter.
-  Course focus 80 mm
-  115 ÷ 230 VAC ± 10 %, 50 ÷ 60 Hz
-  20°C ± 1°C
-  10°C to 40°C
-  80 % without condensing
-  IP40
-  CEI 61010 EN 60204 EN 61326-1
-  110 kg
-  Comes fully assembled, objectives to be ordered separately
-  Shipping packaging
-  Serial Number
-  Declaration of conformity
-  TESA Report



| | | Base | Measuring table | | Digital Readout / Control Panel | | |
|---|---|------|--------------------------|--------------------------|---------------------------------|--------|----------|
| | | | X = 200 mm Y = 100 mm | X = 300 mm Y = 100 mm | TS 100 | TS 300 | TS 300 E |
|  |  | | | | | | |
| TESA-SCOPE II 355H | 06830051 | ● | ● | - | ● | - | - |
| TESA-SCOPE II 355H | 06830052 | ● | ● | - | - | ● | - |
| TESA-SCOPE II 355H | 06830053 | ● | ● | - | - | - | ● |
|  |  | | | | | | |
| TESA-SCOPE II 355H Plus | 06830054 | ● | - | ● | ● | - | - |
| TESA-SCOPE II 355H Plus | 06830055 | ● | - | ● | - | ● | - |
| TESA-SCOPE II 355H Plus | 06830056 | ● | - | ● | - | - | ● |

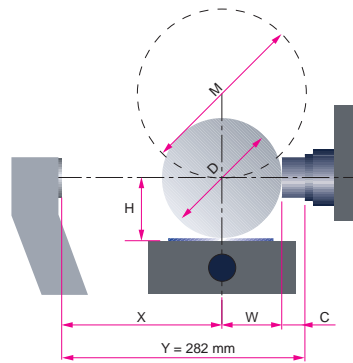
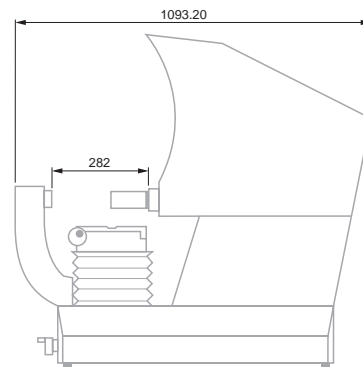
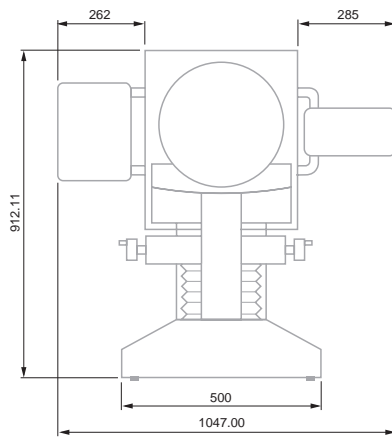

Telecentric Lenses for TESA-SCOPE 355H and 355H Plus

For TESA-SCOPE II 355H and 355H



| No | = | ✳ | ✳ | ✳ | ✳ | ✳ | ⏏ |
|----------|-------------------|------------------|-------------------------|--------------------|----------------------|-------------------------|---------------------------------------|
| | | Objecti-field mm | Working distance (W) mm | Max. Height (H) mm | Max. diameter (D) mm | Objective length (C) mm | Max. width of component X = Y - (W+C) |
| 06860001 | Lens 355H - 10x | 35 | 80 | 100 | 200 | 37 | 165 |
| 06860002 | Lens 355V - 20x | 17,5 | 82 | 100 | 200 | 35 | 165 |
| 06860003 | Lens 355H - 25x | 14 | 70 | 100 | 200 | 47 | 165 |
| 06860004 | Lens 355H - 31,5x | 11.2 | 56 | 100 | 200 | 61 | 165 |
| 06860005 | Lens 355H - 50x | 7 | 53 | 100 | 200 | 64 | 165 |
| 06860006 | Lens 355H - 100x | 3.5 | 43 | 100 | 200 | 74 | 165 |

Accessories for TESA-SCOPE Horizontal Model

For TESA-SCOPE II 355H and 355H Plus

| No | = |
|----------|---|
| 06860018 | 355 mm dia. viewing screen with 4 overlay chart clips |
| 06860020 | Profile lamp, 24 Volts – 150 Watts |
| 06860021 | Surface lamp, 24 Volts – 200 Watts |
| 06860056 | Rotary table for model 355H |
| 06860024 | V-blocks and centres |
| 06860025 | Vise stage |
| 06860026 | Vise stage with base |
| 06860058 | Vise for rotary table N° 06860056 |
| 06860057 | Prise for rotary table N° 06860056 |
| 06769007 | Set of prism |



06860057



06860024



06860058



06860025

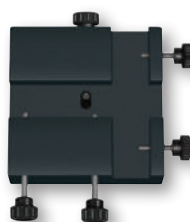

06860026

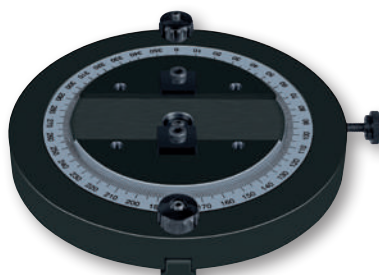

06860056

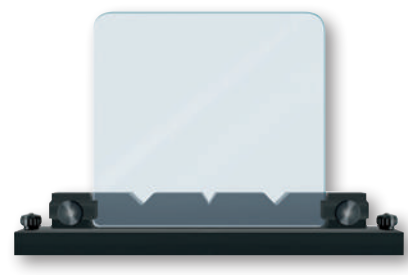

06860059



CONTROL PANELS

3 panels are available with TESA-SCOPE:

- Box TS100
- Control panel TS300 with 2D software TESA REFLEX
- Control panel TS300E with 2D TESA REFLEX software and edge detector

TS100 Digital Readout

- Numerical display (X/Y axes)
- Resolution to 0,001 mm
- Inch/metric conversion
- Separate zeroing of display in both X/Y-axes
- ABS/INC measuring mode
- Linear correction of scaling errors (X/Y-axes)
- Control option for both profile and surface illumination
- RS232 digital output (SPC Printer)

Measuring functions

- Diameter 3 to 10 data points
- Radius 3 to 10 data points
- Centre Centre-to-centre distance of the last distance measured feature (radius or diameter)
- Auto Enter Automatic value acquisition

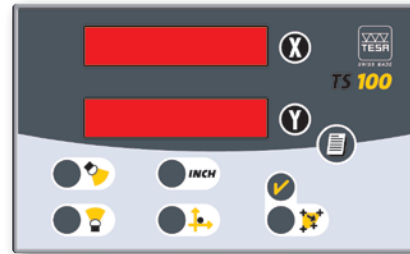

TS300 or TS300E Control Panel

Each unit is able to run TESA-REFLEX 2D – The Reference in terms of simplicity and reliability.

Geometric form elements

- Point
- Line
- Circle

Measuring functions

- Alignment
- Input of reference values
- Translation – Rotation

Construction features

- Intersection
- Bolt hole circle
- Line

Result output

- Data transfer through the RS232 output
- Possible conversion into DXF format
- Statistical data processing etc.

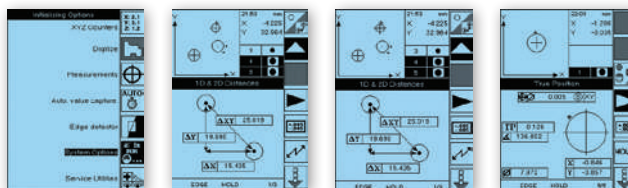

Shipping packaging



RS232
Model 300V: integrated into the unit.
Models 355H : single unit



Icon-based User's guidance



Shipping packaging
89 x 118 mm display field with illuminated background



RS232
7-decade digit display plus sign for all measured values.





Shrinking: less than 1 µm/mm after removal of the mould. Stability: physical properties allow to produce prints which do not deteriorate with time. They will neither be affected by surroundings – hence usable as master standards.



Components with additives free from chlorine, fluorine or sulfur. Being non-toxic and on-polluting can be used with no special restriction



Temperature 20°C



< 10°C: no more polymerization

PLASTIFORM

PLASTIFORM moulding pastes allow print molding of complex internal machined parts, which can then be viewed and checked using optical, non-contact measuring equipment. PLASTIFORM mixing pastes» consist of two components, which have to be mixed in equal proportion to ensure proper polymerization. The test object to be reproduced by print molding must be perfectly clean and grease-free before applying Plastiform.

BAD

Fluid consistency best suited for moulding internal and full prints of small and medium sizes. Medium elasticity (10 % of the core) allows prints to be removed in most cases. Reproduces the finest details and can be used for indirect inspection of the surface finish by sight comparison with use of master roughness specimens. Easily cut with the special cutter.

DAV

DAV of fluid consistency best suited for moulding internal and full prints of small and medium sizes. High elasticity (20 % of the core) allows hard prints to be removed such as large re-entrant angle, groove, complex internal shape. Reproduces fine details. Difficult to cut with the special cutter. Print will be preferably checked as a whole.

RGX80

RGX80 is the hardest product of the cartridge range. Pasty consistency best suited for moulding whole internal prints having varying sizes. Weak stretching property and elasticity make it appropriate for easily removable moulding prints.

LKAD

Malleable consistency best suited for moulding internal, external and sectorial prints of small and medium sizes. Applied by hand. Low elasticity (from 1 to 2% of the core) makes it convenient for moulding prints that are removed with ease. Also appropriate for prints held mechanically if desired. Easily cut with the cutter.

PLASTIFORM Set

PLASTIFORM full case Consisting of:

- 1 DS50 injection handle
- 1 Cutter, special with two parallel blades
- 1 PLASTIN (200 g)
- 50 Mixer-Injectors
- 10 Injector end pieces
- 1 DN1 spot remover, 400 ml 21 Rings for mould removal
- 3 PLASTIFORM BAD 50 ml
- 3 PLASTIFORM DAV 50 ml
- 2 PLASTIFORM RGX80 50 ml



Properties

| | BAD | DAV | RGX80 | LKAD |
|---------------------------------|-----------|-----------------|-------|-----------|
| Consistency (max 15) | Fluid (2) | Fluid (4,5) | Pasty | Malleable |
| Hardness (shore A) | 50 | 20 | 80 | 70 |
| Cut using the dual-blade cutter | Easy | Uneasy | Easy | Easy |
| Check | ● | – | ● | ● |
| – With contact | ● | – | ● | ● |
| – Without contact | ● | ● | ● | ● |
| – Roughness | – | – | ● | – |
| Elasticity | Flexible | Highly flexible | Rigid | Rigid |



06869122



PLASTIFORM Full case



Accessories for PLASTIFORM

- BAD, DAV, RGX80, LKAD Cartridges
- Plastin
- Tests kits
- Mixers-injectors
- Cutter, special with two parallel blades
- Injector nozzles DS50
- DN1 spot remover, aerosol can, 400 ml



| No | = |
|----------|---|
| 06869101 | PLASTIFORM BAD 8 x 50 ml |
| 06869106 | Mixing injectors, box of 50 pcs |
| 06869107 | Mixing injectors, box of 100 pcs |
| 06869108 | Mixing injectors, box of 200 pcs |
| 06869109 | Fine nozzles box of 20 pcs |
| 06869110 | Plastincine, 200 gr |
| 06869111 | Special cutter with two parallel blades |
| 06869112 | Plastiform pistol DS50 |
| 06869113 | Degreasing DN1, aerosol 400 ml |
| 06869102 | PLASTIFORM DAV 8 X 50 ml |
| 06869119 | PLASTIFORM Lite KIT BAD |
| 06869120 | PLASTIFORM Lite KIT DAV |
| 06869118 | PLASTIFORM RGX8 50 ml |
| 06869121 | PLASTIFORM LK-AD |



Coordinate Measuring Machines



THE WAY TO ACCESS 3D MEASUREMENT

Conceived to provide operators with absolute ease of use, the TESA MICRO-HITE 3D steps in to fill the gap between the traditional gauge and the sophisticated CMM. This measuring machine with remarkable capabilities is best used in industrial applications where dimensional conformity of components either produced as single parts or in small to medium batches requires due approval.

Featuring a modern, yet proven design, the machine is built using high quality materials and components, thus ensuring its long-term reliability. The TESA-REFLEX software is intuitive and easy to learn taking only a few hours to master.



MH3D Dual



MH3D 454



MH3D 474





TWO TESA-REFLEX SOFTWARE VERSIONS

The TESA-REFLEX software is the reference for user-friendliness and reliability. Easy and quick to learn and to run, it lets users choose between a large number of options:

- Several modes: measuring, scanning, pass-through.
- Summon and save part programmes.
- Qualification of several probe positions.
- Different ways to save the measurement results: USB stick, RS232 digital output or printer.
- Automated operation

THREE MANUALLY OPERATED PROBE HEADS

All TESA CMM's can accept 3 different manual probe heads to offer the solution that meets each user's need. Each probe head is available from a full range of touch-trigger probes besides high precision SWISS MADE accessories fitting any type of hand-operated measuring machines.

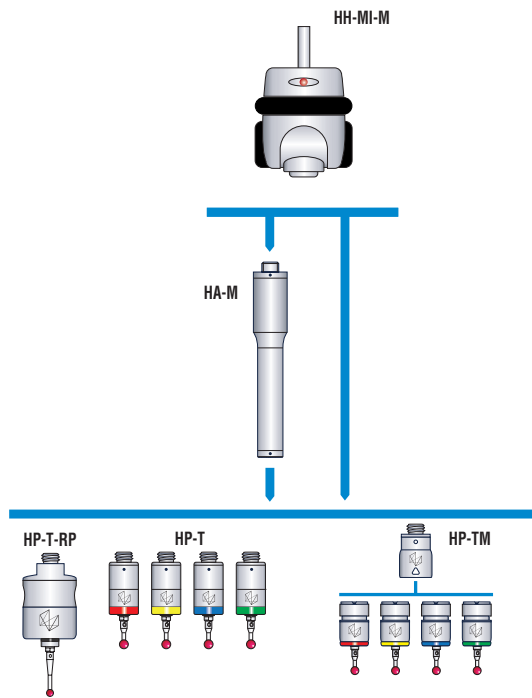



MICRO-HITE 3D Manual

Supplied with TESA-REFLEX software, the MICRO-HITE 3D can turn into a reliable and hard wearing all round shop floor machine easily integrated into the skill set of the operator. Multifunctional, yet easy to use, it is the metrological ace up the inspector's sleeve, replacing a wide range of conventional measuring tools.

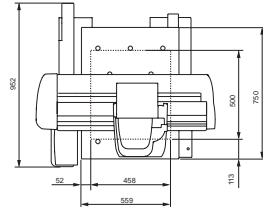
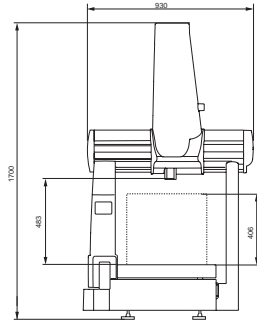

MH3D 454

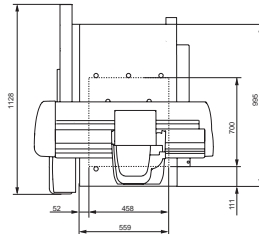
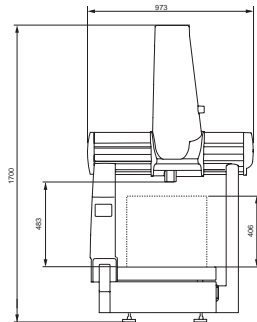

MH3D 474

- EN ISO 10360-2
- 0,001 mm or 0.00001 in
- Opto-electronic measuring systems based on incremental glass scales
- 760 mm/s
- Light alloy machine base, measuring table in granite
- 115 to 230 VAC ± 10 %, 50 to 60 Hz. Absorption 0,3 to 0,7 A
- Air pressure: 3,9 bars (60 to 120 psi). Air absorption: 60 Nm/min.
- 13°C to 35°C
-
- Shipping box (W x D x H) : 1100 x 1150 x 2200 mm (for machine version 454) 1580 x 1400 x 2200 mm (for machine version 474)
- Inspection report
- 154 x 116 mm display field with illuminated background
- Measuring volume (X/Y/Z): 460 x 510 x 420 mm (machine version 454) 460 x 710 x 420 mm (machine version 474)
- Maximum dimensions for measured parts: (W x D x H) : 600 x 750 x 430 mm (for machine version 454) 600 x 990 x 430 mm (for machine version 474)
- CMM with moving bridge. Measuring systems along with air bearing guiding in the three coordinate axes.
- Net weight: Versions (454/474) = 210/315 kg (granite tables included). Tables alone : 99/120 kg. Gross weight : 300/445 kg. Maximum weight for measured parts: Version 454 : 227 kg Version 474 : 200 kg
- 20° ± 1°
- MPEE* = (3 + 4 L/1000) µm MPEP = 3 µm * L in mm
- 0,039 µm (system)
- Manual

| No | = | | | | | | | |
|----------|--------------------|--------------|-----|--------------------|------------------|----------------|-----------------------|----------|
| | | Displacement | mm | Fine adjust device | Software | Measuring head | Maintenance agreement | Warranty |
| 03939040 | MH3D 454 (HH-T) | manual | 454 | No | TESA-REFLEX MH3D | HH-T | On request | 1 year |
| 03939041 | MH3D 454 (HH-M) | manual | 454 | No | TESA-REFLEX MH3D | HH-MI | On request | 1 year |
| 03939042 | MH3D-F 454 (HH-T) | manual | 454 | Yes | TESA-REFLEX MH3D | HH-T | On request | 1 year |
| 03939043 | MH3D-F 454 (HH-MI) | manual | 454 | Yes | TESA-REFLEX MH3D | HH-MI | On request | 1 year |
| 03939240 | MH3D 474 (HH-T) | manual | 474 | No | TESA-REFLEX MH3D | HH-T | On request | 1 year |
| 03939241 | MH3D 474 (HH-M) | manual | 474 | No | TESA-REFLEX MH3D | HH-MI | On request | 1 year |
| 03939242 | MH3D-F 474 (HH-T) | manual | 474 | Yes | TESA-REFLEX MH3D | HH-T | On request | 1 year |
| 03939243 | MH3D-F 474 (HH-MI) | manual | 474 | Yes | TESA-REFLEX MH3D | HH-MI | On request | 1 year |

It is also possible to order a CMM including a HH-MI-M probe head.



MICRO-HITE 3D DUAL

The software is very well suited to the MICRO-HITE 3D DUAL, making it a versatile machine that can be used by everyone, whether in a laboratory or in a workshop. As it can be used in 2 modes this increases productivity and the machine can be used for a longer period of time in the manufacturing chain.

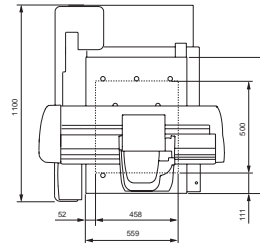
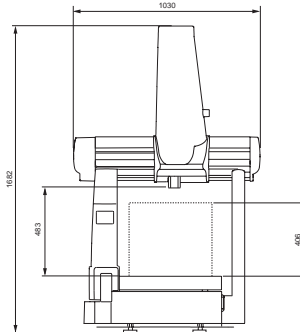

MH3D Dual 454

- EN ISO 10360-2
- 0,001 mm or 0.00001 in
- Opto-electronic systems and incremental glass scales
- Manual mode: 760 mm/s Motorised mode: 200 mm/s
- Light alloy machine base; granite measuring table.
- 115 to 230 VAC ± 10 %, 50 to 60 Hz. Absorption: 0,3 to 0,7 A
- Air pressure: 3,9 bars (70 to 10 psi). Air absorption: 60NI/min.
- 13°C to 35°C
- CE
- shipping box (WxDxH): 1350 x 1350 x 2200 mm
- inspection report
- 154 X 116 mm display field with illuminated background
- Measuring volume (X/Y/Z): 440 x 490 x 390 mm
- Maximum size of the measured part (W/D/H): 600 x 750 x 430mm
- CMM with moving bridge. Measuring systems along with air bearing guiding in the three axes
- Net weight 225 kg (granite table included). Table alone: 99 kg. Gross weight: 350 kg. Maximum weight for the measured part: 227 kg.
- 20°C ± 1°C
- Manual mode: MPEE* = (3 + 4 L/1000) µm
MPEP = 3 µm
Motorised mode: MPEE* = (2,5 + 3,9 L/1000) µm
MPEP = 2 µm
* L in mm
- 0,039 µm (system)
- Manual probing movements. Manual or motorised execution of a part program.

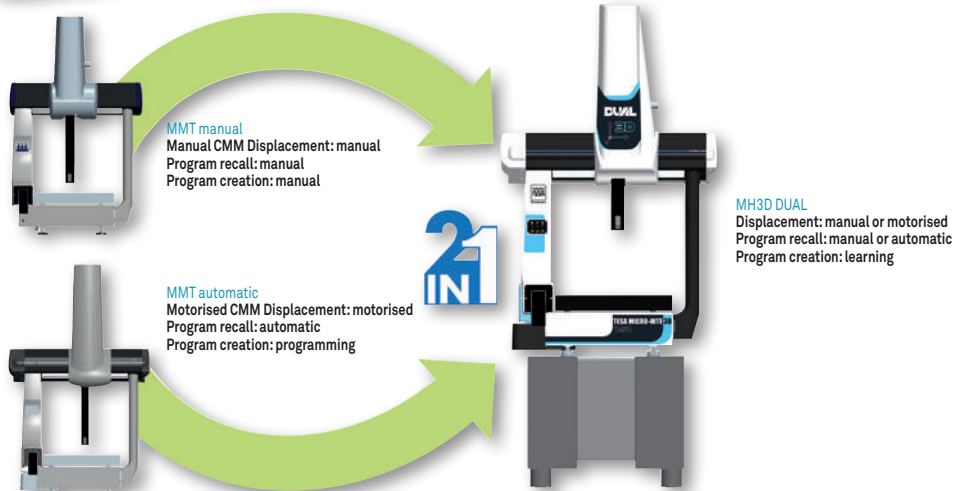

| No | Icon | Displacement | mm | Software | Maintenance agreement | Warranty |
|----------|-------------------------|------------------------------|-----|------------------|-----------------------|-------------------|
| 03939267 | MH3D Dual 454 (HH-T) | manual, motorised, automatic | 454 | TESA-REFLEX Dual | HH-T | On request 1 year |
| 03939268 | MH3D Dual 454 (HH-MI-M) | manual, motorised, automatic | 454 | TESA-REFLEX Dual | HH-MI-M | On request 1 year |
| 03939269 | MH3D Dual 454 (HH-MI) | manual, motorised, automatic | 454 | TESA-REFLEX Dual | HH-MI | On request 1 year |



HH-T Head

The HH-T is a compact manual probe head with adjustable triggering force.

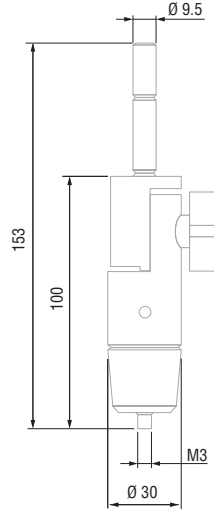

EN ISO 10360-1



Directions:
± X, ± Y, +Z
Free stylus travel:
X/Y ±20°, Z + 6 mm



-30°C to 60°C



10°C to 40°C



Shipping box



Inspection report
with a declaration
of conformity



M3



Manual



Unidirectional, μm
 $\leq 0,75$



N



0,1 ÷ 0,3



M3

Manual





EN ISO 10360-1

Directions: ± X, ± Y, +Z
Free stylus travel: X/Y ± 20°, Z + 6 mm

-30°C to 60°C

10°C to 40°C

Shipping box

Inspection report with a declaration of conformity

Each axis can be locked by means of 2 push-buttons

M3

Indexation in increment of 15°

Indexation on 168 positions. Probe orientation: A = 0° to 90° B = ± 180°

Manual

HH-MI Head

The HH-MI is a high-precision indexable probe head integrating a built-in sensor with adjustable triggering force.

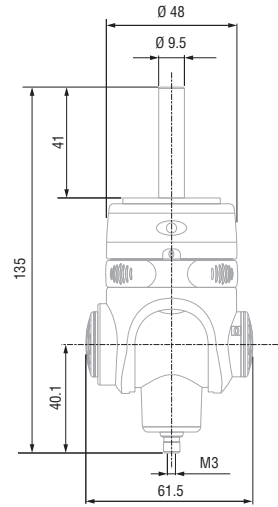

| | | | | | | | |
|----------|------------|-----|-----|--------|-----------|----|--------|
| | | | | | | | |
| 03939030 | HH-MI Head | 15° | 168 | ≤ 0,75 | 0,1 ÷ 0,3 | M3 | Manual |



EN ISO 10360-1

Each axis can be locked by means of 2 push-buttons

-30°C to 60°C

10°C to 40°C

Shipping box

Inspection report with a declaration of conformity

M8

Indexation by increment of 15°

Indexation on 168 positions. Probe orientation: A = 0° to 90° B = ± 180°

Manual

HH-MI-M Head

The HH-MI-M is a high-precision, indexable manual probe head which can be fitted with any type of accessories featuring a M8 coupling thread.

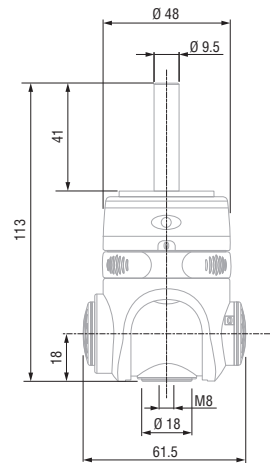

| | | | | | | | |
|----------|--------------|-----|-----|---|---|----|--------|
| | | | | | | | |
| 03939031 | HH-MI-M Head | 15° | 168 | - | - | M8 | Manual |



HP-T Probe

Consist of a small-size module with integrated probe and touch force triggered in 5 directions. M8 thread for coupling any existing probe head, whether manually operated or motor driven. Four models available with a trigger force varying from 0,05 up to 0,10 N.

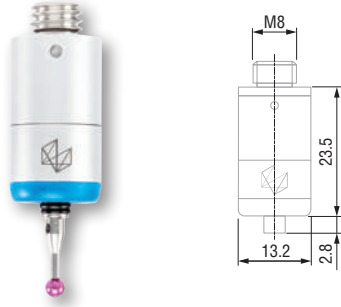

| No | = | | | | |
|----------|---------|------|-------------------|--------|---------------------|
| | | µm | N | Colour | |
| 03939070 | HP-T-LF | 0,35 | 0,055 (L = 10 mm) | Red | LF = Low Force |
| 03939071 | HP-T-SF | 0,35 | 0,08 (L = 10 mm) | Yellow | SF = Standard Force |
| 03939072 | HP-T-MF | 0,5 | 0,10 (L = 25 mm) | Green | MF = Medium Force |
| 03939073 | HP-T-EF | 0,65 | 0,10 (L = 50 mm) | Blue | EF = Extended Force |

HP-T Probe Kit

Kit including several HP-T probes, allowing to face any application case with different triggering forces.

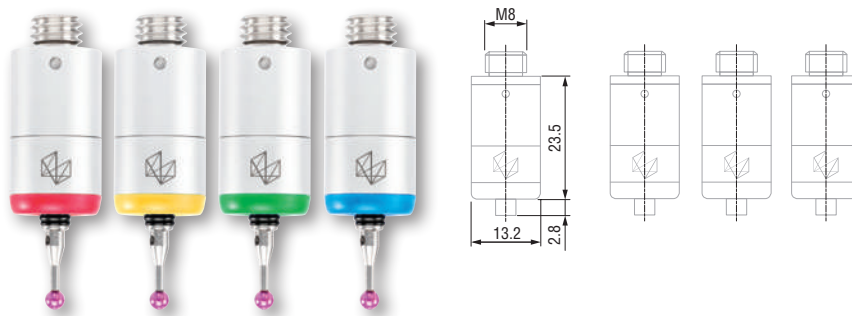

| No | = | | |
|----------|----------------|----------------|-----------------------------------|
| 03939074 | HP-T probe kit | Standard probe | 1 x LF + 1 x MF + 1 x SF + 1 x EF |

- 600 µA (external supply)
- 5 directions ± X, ± Y, +Z Free stylus travel: X/Y ± 14°, Z + 4 mm
- 10°C to 70°C
- 10°C to 40°C
- IP50
- Shipping box
- Inspection report with a declaration of conformity
- M2
- 9,5 g





600 μ A
(external supply)

5 directions \pm X, \pm Y,
+Z Stylus tilting
through X/Y $\pm 14^\circ$,
Z + 4 mm

-30°C to 60°C

10°C to 40°C

IP30

Shipping packaging

Inspection report
with a declaration
of conformity

M2

Triggering force:
10N

13,6 g (probe body)
11 g (stylus)

HP-TM Probe

The HP-TM is a small system incorporating a magnetic and isostatic attachment between its body, fixed part of the attachment, and its module, interchangeable part, equipped with a measuring force triggered by contact in 5 directions.

Four models with a varying triggering force between 0,05 N and 0,10 N are available. The body is equipped with a M8 thread for mounting on most existing motorized or manual measuring heads.

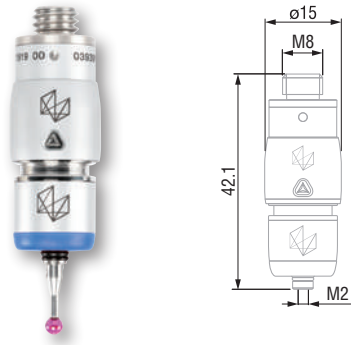

| No | = | | | | |
|----------|------------------|---------|-------------------|---------|---------------------|
| | | μ m | N | Couleur | |
| 03939170 | HP-TM-LF | 0,35 | 0,055 (L = 10 mm) | Red | LF = Low Force |
| 03939171 | HP-TM-SF | 0,35 | 0,08 (L = 10 mm) | Yellow | SF = Standard Force |
| 03939172 | HP-TM-MF | 0,5 | 0,10 (L = 25 mm) | Green | MF = Medium Force |
| 03939173 | HP-TM-EF | 0,65 | 0,10 (L = 50 mm) | Blue | EF = Extended Force |
| 03939174 | HP-TM probe body | - | - | - | - |

HP-TM Probe Kit

Probe kit including a HP-TM probe body and several modules, allowing fast, easy and safe changes in the system, without any negative impact on the measuring results.

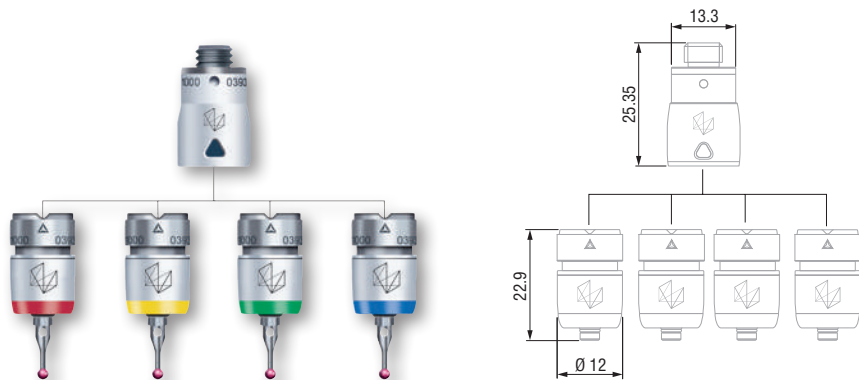

| No | = | | |
|----------|----------------------|----------------|--------------------------------------|
| 03939175 | Probe kit HP-TM N°1 | Magnetic probe | 1x LF + 1x MF + 1x SF + 1x EF + body |
| 03939210 | Probe kit HP-TM N°2 | Magnetic probe | 2x SF + body |
| 03939211 | Probe kit HP-TM N°3 | Magnetic probe | 1x SF + 1x MF + body |
| 03939212 | Probe kit HP-TM N°4 | Magnetic probe | 1x SF + 1x EF + body |
| 03939213 | Probe kit HP-TM N°5 | Magnetic probe | 2x MF |
| 03939214 | Probe kit HP-TM N°6 | Magnetic probe | 1x EF + 1x MF + body |
| 03939215 | Probe kit HP-TM N°7 | Magnetic probe | 2x EF + body |
| 03939216 | Probe kit HP-TM N°8 | Magnetic probe | 1x LF + body |
| 03939217 | Probe kit HP-TM N°9 | Magnetic probe | 1x SF |
| 03939218 | Probe kit HP-TM N°10 | Magnetic probe | 1x MF + body |
| 03939219 | Probe kit HP-TM N°11 | Magnetic probe | 1x EF + body |



HP-T-RP Probe

HP-T-RP is a complete, robust and precise touch trigger probe, which can be used on any manual or motorised CMM as well as in any manufacturing environment, even the most hostile. Adjustable triggering force for optimum efficiency according to chosen configuration for the stylus. This force also allows for the use of styli whose weight and length are above normal.

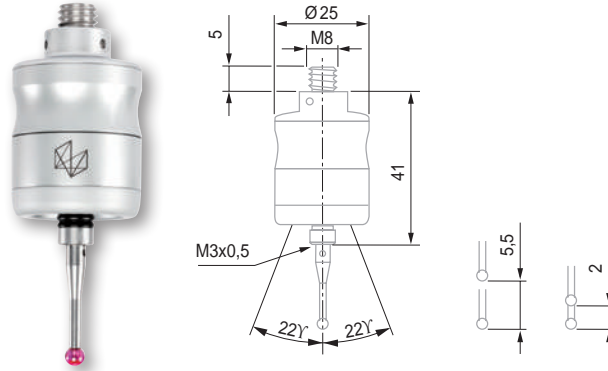

- 600 µA (external supply)
- 5 directions ± X, ± Y, +Z Free stylus travel: X/Y ±22°, Z + 5,5 mm
- 10°C to 70°C
- 10°C to 40°C
- IP50
- Shipping box
- Inspection report with a declaration of conformity
- M3
- 43 g

| No | Symbol | Unidirectional, µm | N | Robust probe | Length of stylus, mm | RP = Robust Probe |
|----------|---------|--------------------|-----------|--------------|----------------------|-------------------|
| 03939350 | HP-T-RP | ≤ 0,35 | 0,1 ÷ 0,3 | Robust probe | ≤ 100 | RP = Robust Probe |





Ruby Ball Stylus, M2 Thread

These styli are used for the majority of probing applications. Highly robust, thanks to their manufacture from industrial rubies, they are however very sensitive, thus avoiding any capture of unwanted points during the movements of a 3D machine.

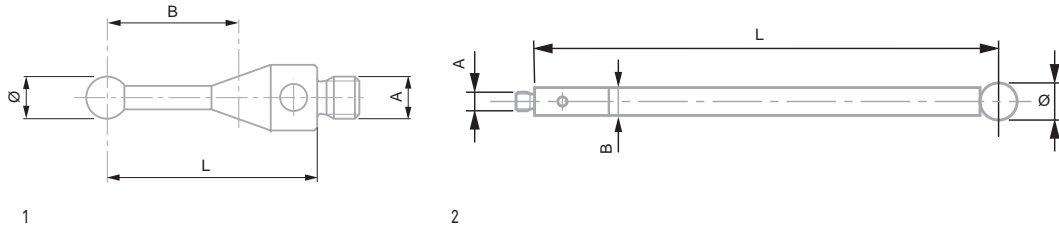







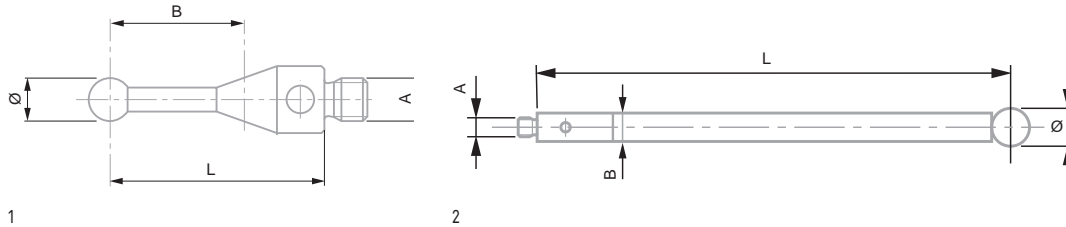

| No | Rod | Drawing N° | A mm | Ø mm | L mm | B mm | g |
|----------|------------------|------------|------|------|------|------|------|
| 03969201 | Inox | 1 | M2 | 1 | 10 | 4,5 | 0,3 |
| 03969202 | Inox | 1 | M2 | 2 | 10 | 6 | 0,3 |
| 03969203 | Inox | 1 | M2 | 3 | 10 | 7,5 | 0,4 |
| 03969204 | Inox | 1 | M2 | 4 | 10 | 10 | 0,5 |
| 03969205 | Inox | 1 | M2 | 5 | 10 | 10 | 0,7 |
| 03969206 | Inox | 1 | M2 | 6 | 10 | 10 | 1 |
| 03969208 | Inox | 1 | M2 | 8 | 11 | 11 | 1,5 |
| 03969212 | Inox | 1 | M2 | 2 | 20 | 14 | 0,5 |
| 03969213 | Inox | 1 | M2 | 3 | 20 | 17 | 0,5 |
| 03969214 | Inox | 1 | M2 | 4 | 20 | 20,2 | 0,8 |
| 03969220 | Tungsten carbide | 1 | M2 | 0,5 | 10 | 3 | 0,3 |
| 03969221 | Tungsten carbide | 1 | M2 | 1 | 20 | 7 | 0,6 |
| 03969222 | Tungsten carbide | 1 | M2 | 2 | 20 | 15 | 0,45 |
| 03969223 | Ceramic | 1 | M2 | 3 | 50 | 42,5 | 0,83 |
| 03969224 | Ceramic | 1 | M2 | 4 | 50 | 42,5 | 0,91 |
| 03969225 | Inox | 1 | M2 | 2,5 | 10 | 6 | 0,3 |
| 03969226 | Tungsten carbide | 1 | M2 | 2,5 | 20 | 14 | 0,4 |
| 03969259 | Tungsten carbide | 1 | M2 | 1 | 27 | 20,5 | 0,4 |
| 03969260 | Carbon | 2 | M2 | 4 | 50 | 3 | 1 |
| 03969261 | Tungsten carbide | 1 | M2 | 1,5 | 30 | 25 | 0,58 |
| 03969262 | Tungsten carbide | 1 | M2 | 2 | 30 | 25 | 0,99 |
| 03969263 | Tungsten carbide | 1 | M2 | 3 | 30 | 25 | 1,49 |
| 03969267 | Tungsten carbide | 1 | M2 | 0,7 | 10 | 4 | 0,3 |
| 03969268 | Tungsten carbide | 1 | M2 | 0,3 | 10 | 2 | 0,3 |
| 03969269 | Tungsten carbide | 1 | M2 | 0,5 | 20 | 7 | 0,48 |
| 03969271 | Tungsten carbide | 1 | M2 | 1 | 20 | 12,5 | 0,41 |
| 03969272 | Tungsten carbide | 1 | M2 | 1,5 | 20 | 12,5 | 0,5 |
| 03969276 | Carbon | 2 | M2 | 6 | 50 | 50 | 1,2 |
| 03969282 | Tungsten carbide | 1 | M2 | 2 | 40 | 35 | 1,29 |
| 03969283 | Tungsten carbide | 1 | M2 | 3 | 40 | 35 | 1,97 |
| 03969284 | Tungsten carbide | 1 | M2 | 3 | 40 | 35 | 2,04 |
| 03969286 | Carbon | 2 | M2 | 6 | 30 | 30 | 0,96 |
| 03969293 | Carbide | 1 | M2 | 3 | 50 | 42,5 | 2,44 |
| 03969294 | Carbide | 1 | M2 | 4 | 50 | 42,5 | 2,52 |
| 03969295 | Tungsten carbide | 1 | M2 | 5 | 50 | 42,5 | 3,75 |



Ruby Ball Stylus, M3 Thread

These styli are used for the majority of probing applications. Highly robust, thanks to their manufacture from industrial rubies, they are however very sensitive, thus avoiding any capture of unwanted points during the movements of a 3D machine.



| No |  |  |  |  |  |  |  |
|----------|---|---|---|---|---|---|---|
| | Rod | Drawing N° | A mm | Ø mm | L mm | B mm | g |
| 03969301 | Inox | 1 | M3 | 1 | 21 | 4 | 1,1 |
| 03969302 | Inox | 1 | M3 | 2 | 21 | 8 | 1,1 |
| 03969303 | Inox | 1 | M3 | 3 | 21 | 12 | 1,1 |
| 03969304 | Inox | 1 | M3 | 4 | 21 | 17 | 1,4 |
| 03969305 | Inox | 1 | M3 | 5 | 21 | 21 | 1,55 |
| 03969310 | Tungsten carbide | 1 | M3 | 0,5 | 21 | 3 | 1,1 |
| 03969312 | Tungsten carbide | 1 | M3 | 2 | 21 | 15 | 0,8 |
| 03969324 | Inox | - | M3 | 3 | 10 | - | - |
| 03969326 | Inox | - | M3 | 6 | 10 | - | - |
| 03969332 | Tungsten carbide | 1 | M3 | 2,5 | 21 | 12,5 | 1,3 |
| 03969343 | Tungsten carbide | 1 | M3 | 3 | 40 | 32,5 | 2,3 |
| 03969353 | Tungsten carbide | 1 | M3 | 3 | 50 | 42,5 | 2,78 |









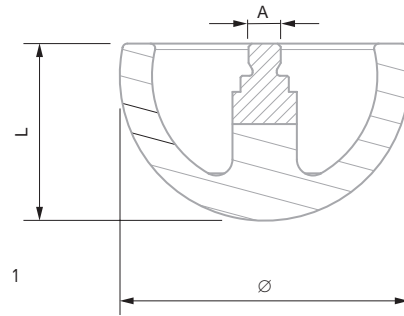

Hemispherical Styli, M2 Thread

Styli usually made of ceramic are generally used to measure deep bores or to avoid taking into account the unwanted irregularities when measuring.









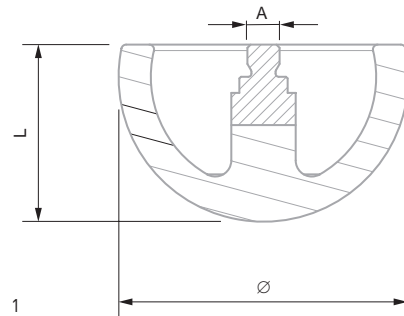

| No | = |  |  |  |  |  |  |  |
|----------|-------------------------------|---|---|---|---|---|---|---|
| 03969218 | Hemispherical stylus, Ø 18 mm | Ceramic | 1 | M2 | 18 | 11 | - | 3,3 |



Hemispherical Styli, M3 Thread

Styli usually made of ceramic are generally used to measure deep bores or to avoid taking into account the unwanted irregularities when measuring.



| No | = |  |  |  |  |  |  |  |
|----------|-------------------------------|---|---|---|---|---|---|---|
| 03969330 | Hemispherical stylus, Ø 30 mm | Ceramic | 1 | M3 | 30 | 17 | - | 13 |



Star Styli, M2 Thread

These styli are supplied with several ruby ball tips fixed in different directions. This feature allows a much faster measurement when inspecting internal features without time being wasted by changing the position of a probe.

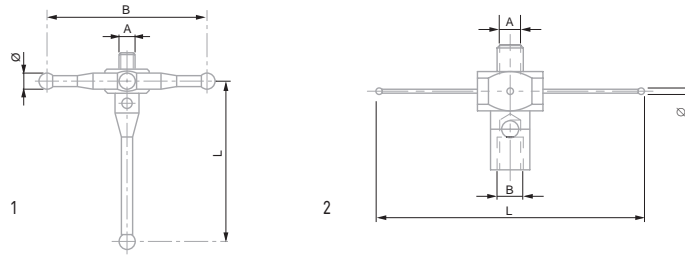

| No | Icon | Rod | Drawing N° | A mm | Ø mm | L mm | B mm | g |
|----------|---------------------------|------|------------|------|------|------|------|-----|
| 03969055 | Star stylus, 5 directions | Inox | 1 | M2 | 2 | 20 | 20 | 1,5 |
| 03969056 | Star stylus, 5 directions | Inox | 1 | M2 | 2 | 20 | 30 | 1,8 |
| 03969081 | Star stylus, 5 directions | Inox | 1 | M2 | 2 | 18 | 20 | 1,3 |
| 03969082 | Star stylus, 5 directions | Inox | 1 | M2 | 2 | 18 | 30 | 1,7 |
| 03969210 | Star stylus, 4 directions | Inox | 2 | M2 | 0,5 | 20 | M2 | 0,7 |

Star Styli, M3 Thread

These styli are supplied with several ruby ball tips fixed in different directions. This feature allows a much faster measurement when inspecting internal features without time being wasted by changing the position of a probe.

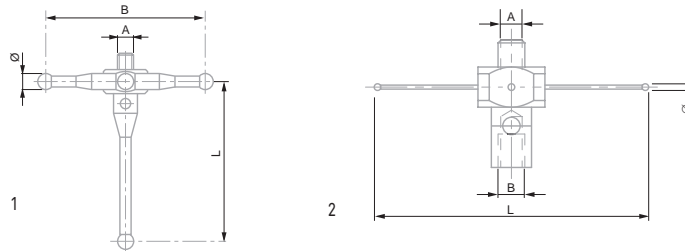

| No | Icon | Rod | Drawing N° | A mm | Ø mm | L mm | B mm | g |
|----------|---------------------------|------|------------|------|------|------|------|-----|
| 03969057 | Star stylus, 5 directions | Inox | 1 | M2 | 2 | 20 | 20 | 2,2 |
| 03969058 | Star stylus, 5 directions | Inox | 1 | M2 | 2 | 20 | 30 | 2,5 |
| 03969083 | Star stylus, 5 directions | Inox | 1 | M2 | 2 | 18 | 20 | 2,2 |
| 03969084 | Star stylus, 5 directions | Inox | 1 | M2 | 2 | 18 | 30 | 2,5 |

Cylindrical Styli, M2 Thread

These styli are principally used for the measurement of threads.

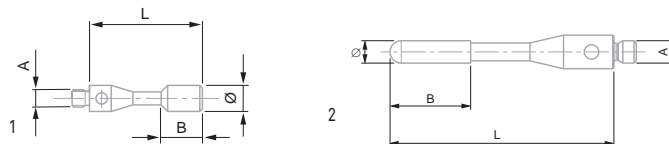

| No | Rod | Drawing N° | A mm | Ø mm | L mm | B mm | g |
|----------|------------------|------------|------|------|------|------|-----|
| 03969251 | Inox | 1 | M2 | 1,5 | 11 | 1,5 | 0,3 |
| 03969252 | Inox | 1 | M2 | 3 | 13 | 3,8 | 0,6 |
| 03969253 | Inox | 1 | M2 | 3 | 13 | 4 | 0,5 |
| 03969292 | Tungsten carbide | 2 | M2 | 2 | 20 | 7,2 | 0,5 |





Parallel Styli, M2 Thread

These styli are principally used for the measurement of threads.

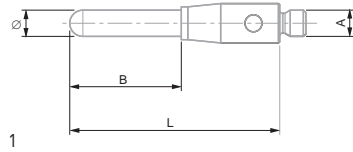

| No | Rod | Drawing N° | A mm | Ø mm | L mm | B mm | g |
|----------|---------|------------|------|------|------|------|-----|
| 03969277 | Carbide | 1 | M2 | 0,5 | 15,3 | 7,8 | 0,3 |
| 03969278 | Carbide | 1 | M2 | 1 | 35,5 | 29,8 | 0,7 |
| 03969279 | Carbide | 1 | M2 | 2 | 16 | 8,5 | 0,8 |
| 03969280 | Carbide | 1 | M2 | 2 | 40 | 32 | 2 |
| 03969281 | Carbide | 1 | M2 | 3 | 22,5 | - | 2 |



Extension M2

The extension allows to enlarge the distance between the probe and the tip of the stylus in order to avoid collision in the depth measurement (e.g. bore).

The use of extensions can greatly reduce the accuracy of the measuring system.

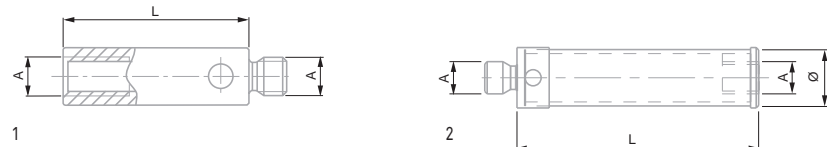

| No | Extension | Rod | Drawing N° | A mm | Ø mm | L mm | B mm | g |
|----------|-------------------|---------|------------|------|------|------|------|------|
| 03969230 | Extension, L5 mm | Inox | 1 | M2 | 3 | 5 | - | - |
| 03969231 | Extension, L10 mm | Inox | 1 | M2 | - | 10 | - | 0,5 |
| 03969232 | Extension, L20 mm | Inox | 1 | M2 | - | 20 | - | 1 |
| 03969233 | Extension, L30 mm | Inox | 1 | M2 | - | 30 | - | 1,6 |
| 03969234 | Extension, L40 mm | Inox | 1 | M2 | 3 | 40 | - | 1,8 |
| 03969238 | Extension, L50 mm | Carbon | 1 | M2 | 3 | 50 | - | 1 |
| 03969239 | Extension, L70 mm | Carbon | 1 | M2 | 3 | 70 | - | 1,3 |
| 03969240 | Extension, L90 mm | Carbon | 1 | M2 | 3 | 90 | - | 1,5 |
| 03969246 | Extension, L40 mm | Ceramic | 1 | M2 | 3 | 40 | - | 1,22 |
| 03969247 | Extension, L50 mm | Ceramic | 1 | M2 | 3 | 50 | - | 1,51 |
| 03969270 | Extension, L40 mm | Carbon | 1 | M2 | 3 | 40 | - | 0,9 |



Extension M3

The extension allows to enlarge the distance between the probe and the tip of the stylus in order to avoid collision in the depth measurement (e.g. bore).

The use of extensions can greatly reduce the accuracy of the measuring system.

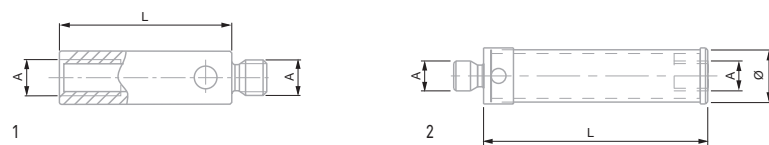

| No | Extension | Rod | Drawing N° | A mm | Ø mm | L mm | B mm | g |
|----------|-------------------|------|------------|------|------|------|------|-----|
| 03969044 | Extension, L10 mm | Inox | 1 | M3 | - | 10 | - | 0,8 |
| 03969045 | Extension, L20 mm | Inox | 1 | M3 | - | 20 | - | 1,8 |
| 03969320 | Extension, L35 mm | Inox | 1 | M3 | - | 35 | - | 2,9 |



Cross-pieces, M2

Base on which one or several identical or different kind of styli can be mounted. It can be converted into a star stylus or any other desirable configuration.

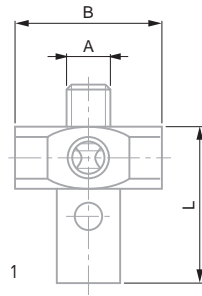

| No | = | | Drawing N° | A mm | Ø mm | L mm | B mm | g |
|----------|------------------------------|-------------|------------|------|------|------|------|-----|
| 03969054 | 5 way cross shaped stylus M2 | Rod Inox | 1 | M2 | - | 7,5 | 7 | 1,1 |

Cross-pieces, M3

Base on which one or several identical or different kind of styli can be mounted. It can be converted into a star stylus or any other desirable configuration.

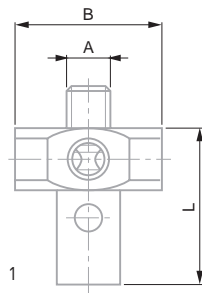

| No | = | | Drawing N° | A mm | Ø mm | L mm | B mm | g |
|----------|------------------------------|-------------|------------|------|------|------|------|-----|
| 03969046 | 5 way cross shaped stylus M3 | Rod Inox | 1 | M3 | - | 13 | 10 | 3,7 |

M2 Adaptors

In some cases, accessories that are directly compatible with a probe are not suitable for specific applications. Therefore, it is possible to use an adaptor in order to mount other styli with different threads on it.

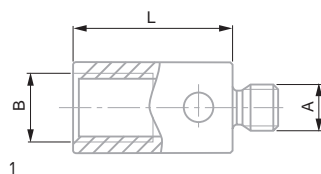

| No | = | | Drawing N° | A mm | Ø mm | L mm | B mm | g |
|----------|---------------|-------------|------------|------|------|------|------|-----|
| 03969061 | Adapter M2-M3 | Rod Inox | 1 | M2 | - | 7 | M3 | 0,5 |





M3 Adaptors

In some cases, accessories that are directly compatible with a probe are not suitable for specific applications. Therefore, it is possible to use an adaptor in order to mount other styli with different threads on it.

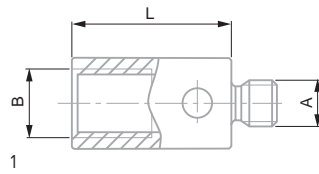

| No | = | | | | | | | |
|----------|---------------|------|------------|------|------|------|------|-----|
| | | Rod | Drawing N° | A mm | Ø mm | L mm | B mm | g |
| 03969062 | ADAPTER M3-M2 | Inox | 1 | M3 | - | 5 | M2 | 0,5 |



Stylus Tightening Keys

Probes and styli are fragile and sensitive items. A special key is provided for fixing a stylus on the probe in order to prevent any damages caused by over-tightening.

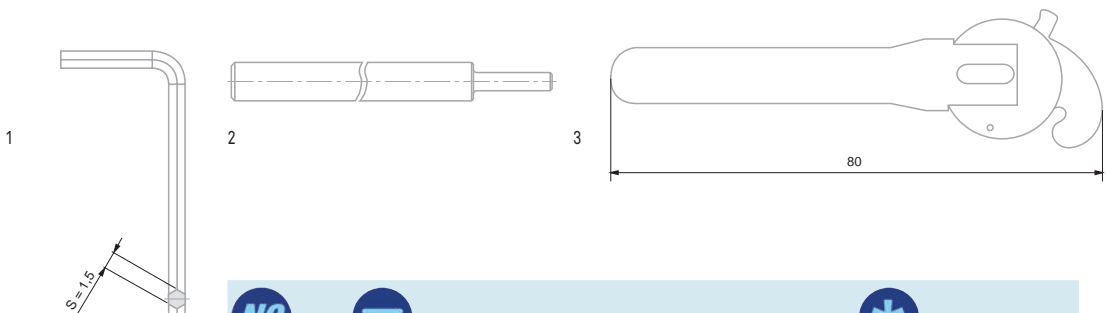

| No | = | |
|--------|---------------------------------------|------------|
| | | Drawing N° |
| 042086 | Hexagonal key 1,5 mm | 1 |
| 047866 | Stylus key M2 or M3 | 2 |
| 050697 | Tightening key for carbon fibre styli | 3 |



Stylus Kit

In order to perform several types of measurement, it is often necessary to keep several models of styli. This is why TESA has created standard kits, comprising styli for a variety of dimensions as well as extensions to suit.



| No | | Kit N° 1, M2 03969086 | Kit N° 2, M2 03969087 | Kit N° 3, M2 + rigid probe 03969089 | Kit N° 1, M3 03969101 | Kit N° 2, M3 + rigid probe 03969040 |
|----------|--|-----------------------------|-----------------------------|---|-----------------------------|---|
| 03969085 | Case for accessories | 1 | | | | |
| 047866 | Stylus key M2 or M3 | 2 | | | | |
| 049652 | Key | 2 | | | | |
| 050697 | Tightening key for carbon fibre styli | 2 | | | | |
| 03969231 | Extension, inox, M2, L = 10 mm | 1 | 1 | 1 | | |
| 03969232 | Extension, inox, M2, L = 20 mm | 1 | 1 | 1 | | |
| 03969233 | Extension, inox, M2, L = 30 mm | | 1 | | | |
| 03969270 | Extension, carbone, M2, L = 40 mm | 1 | | | | |
| 03969044 | Extension, inox, M3, L = 10 mm | | | | 1 | 1 |
| 03969045 | Extension, inox, M3, L = 20 mm | | | | 1 | 1 |
| 03969054 | 5 way cross shaped stylus, inox, M2 | 1 | | 1 | | |
| 03969046 | 5 way cross shaped stylus, inox, M3 | | | | 1 | 1 |
| 03969082 | 5 way cross shaped stylus, inox, M2 | 1 | | | | |
| 03969201 | Stylus, inox, ruby ball tip, M2, Ø 1 mm, L = 10 mm | | 1 | | | |
| 03969202 | Stylus, inox, ruby ball tip, M2, Ø 2 mm, L = 10 mm | 1 | 1 | | | |
| 03969203 | Stylus, inox, ruby ball tip, M2, Ø 3 mm, L = 10 mm | | 1 | | | |
| 03969204 | Stylus, inox, ruby ball tip, M2, Ø 4 mm, L = 10 mm | 1 | 1 | | | |
| 03969212 | Stylus, inox, ruby ball tip, M2, Ø 2 mm, L = 20 mm | 2 | | 1 | | |
| 03969213 | Stylus, inox, ruby ball tip, M2, Ø 3 mm, L = 20 mm | 2 | | 1 | | |
| 03969221 | Stylus, carbide, ruby ball tip, M2, Ø 1 mm, L = 20 mm | 1 | | | | |
| 03969260 | Stylus, carbone ruby ball tip, M2, Ø 4 mm, L = 50 mm | 1 | | | | |
| 03969302 | Stylus, inox, ruby ball tip, M3, Ø 2 mm, L = 21 mm | | | | 1 | 1 |
| 03969303 | Stylus, inox, ruby ball tip, M3, Ø 3 mm, L = 21 mm | | | | 1 | 1 |
| 03969304 | Stylus, inox, ruby ball tip, M3, Ø 4 mm, L = 21 mm | | | | 1 | 1 |
| 03969214 | Stylus, inox, ruby ball tip, Ø 4 mm, L = 20 mm | | | 1 | | |
| 03969047 | Rigid probe, Ø 6.35 mm | | | 1 | | 1 |



Basic Fixturing System

The basic clamping kit is perfect for fixing easily any prototype or single parts by using the inserts integrated in the granit measuring table of the TESA measuring machine.

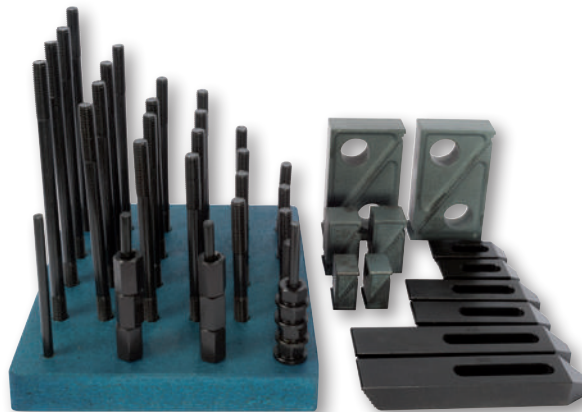

03969010 Basic fixuring kit Is directly compatible with the inserts of the ganit table of the coordinate measuring machine.

Advanced Clamping System

Advanced clamping kit is an easy-to-use system built around the vertical supports to be screwed onto a base-plate. Other specific components are designed to be coupled to the extremity of the columns in order to optimise the flexibility of the device, obtain exactly the required heights and to lock at best the part to be measured.



| | | |
|-----------------|------------------------------|--|
| 03969504 | Bronze SWIFTFIX Kit | = 03969507 + 03969510 |
| 03969505 | Silver SWIFTFIX Kit | = 03969508 + 03969510 |
| 03969506 | Gold SWIFTFIX Kit | = 03969509 + 03969510 |
| 03969507 | Bronze FIXTURE Kit Case | Includes 46 fixuring elements, without baseplate |
| 03969508 | Silver FIXTURE Kit Case | Includes 66 fixuring elements, without baseplate |
| 03969509 | Gold FIXTURE Kit Case | Includes 93 fixuring elements, without baseplate |
| 03969510 | 400 x 400 SWIFTFIX Baseplate | 400 x 400 x 12 mm |



Additional Software

As it is sometimes necessary to adapt your machine and the measurement process to specific needs, TESA offers additional software that makes the instrument more powerful.



| No | = | ✳ |
|----------|----------------------|--|
| 03969009 | REFLEXSCAN 3D | For reverse engineering |
| 04981004 | STAT-EXPRESS Machine | To get real-time statistics |
| 04981001 | DATA-DIRECT | For the collection and processing of measurement data in real time |

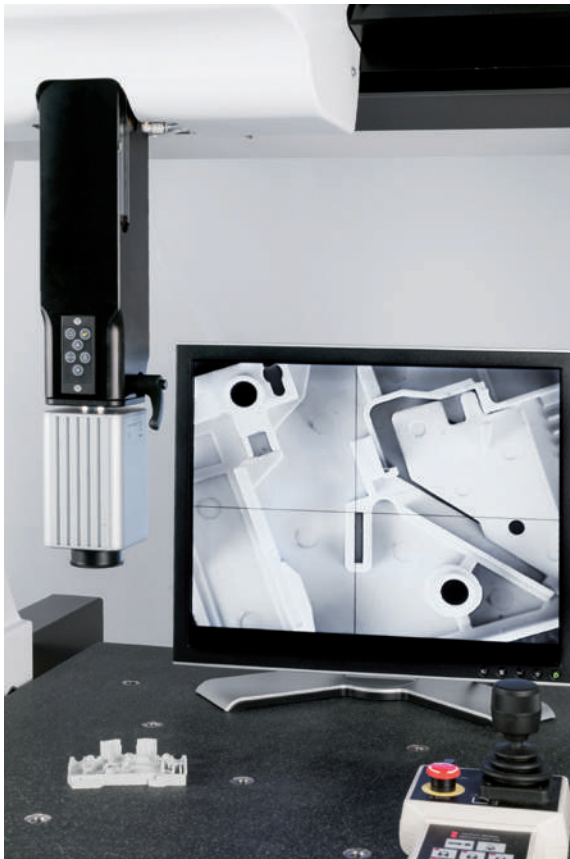

Camera Kit

This kit makes it easy to convert any 3D TESA machine into a profile projector! There is no need to own two separate machines to take readings of certain features that are impossible to measure in a tactile way, such as engravings or small parts.



| No | = | ✳ |
|-----------|------------------|----------------|
| S39040072 | Camera kit No. 1 | With screen |
| S39040070 | Camera kit No. 2 | Without screen |



|  No |  |
|--|---|
| 03969065 | Extension M8, L = 50 mm |
| 03960175 | Air saver |
| 03960172 | Separator |
| 03969003 | Protective cover |
| H005471 | Joystick for MH3D Dual |
| 03969103 | Diaclean 1 l |
| 03969047 | Rigid probe |
| 82-1631 | TESA demo block |
| 03969095 | HEXAGON demo block |
| 03969011 | Qualification sphere without certificate |
| 03969511 | Qualification sphere with certificate |
| 03969001 | MH3D table with drawers |
| 03960270 | Table for MH3D |
| S39900072 | USB printer |



TRADEMARKS REGISTERED IN SWITZERLAND AND/OR OTHER COUNTRIES



TECHNOLOGY



CARY

SWISS



- TESA
- TESA fig.
- ALESOMETRE
- ALESOTEST
- CAPA μ SYSTEM fig.
- CARY
- COMPAC
- COMPAC fig.
- COMPAC GENEVE fig.
- DIAMASTER
- DIGICO
- DIGIT-CAL
- DIGITMASTER
- DURA-CAL
- ETALON
- ETALON fig.
- ETALON SWITZERLAND fig.
- IMICRO
- INOTEST
- INTERAPID
- INTERAPID fig.
- ISOMASTER
- JUNIOR
- JUNIOR fig.
- MAGNA μ SYSTEM fig.
- MERCER
- MESOBOR
- MICRO-HITE
- MICROMASTER
- μ HITE fig.
- POPCAL
- ROCH FRANCE fig.
- ROCTEST
- RUGOSURF fig.
- SHOPCAL
- STANDARD GAGE fig.
- TESA DIGITMASTER
- TESA DUOTAST
- TESA EAGLE fig.
- TESA-HITE
- TESA MEMO-HITE
- TESA MICRO-HITE
- TESA MULTI-GAGE
- TESA-REFLEX
- TESA SWISSCAL
- TESA SWISSTAST
- TESACAL
- TESADIA
- TESADIGIT
- TESAMASTER
- TESA- μ HITE fig.
- TESANORM fig.
- TESASCAN
- TESA-SCOPE
- TESASET
- TESASTAR
- TESASTAR fig.
- TESATAST
- TESATRONIC
- TESATRONIC MULTILINE
- TESA-VISIO
- TRI-O-BOR
- TRIOMATIC
- UNIMASTER
- UNITEST
- UNITEST fig.
- VERIBOR



NUMERICAL INDEX



| | | | | | |
|--------------------|---------------------------|-------------------------|----------------------------|----------------------|--------------------|
| 001 | 00250505..... C-19 | 00510711..... B-14 | 00530841..... B-14 | 00760173..... N-25 | 00840113..... D-17 |
| 00110101..... C-6 | 00269027..... C-16 | 00510721..... B-14 | 00531004..... C-32 | 00760175..... N-27 | 00840114..... D-17 |
| 29, 30, 31 | | 00510722..... B-14 | 00531005..... C-32 | 00760186..... N-28 | 00840115..... D-17 |
| 00110102..... C-6 | 003 | 00510741..... B-14 | 00531006..... C-33 | 00760194..... N-23 | 00840116..... D-17 |
| 00110103..... C-6 | 00310001..... C-4, 30, 31 | 00510751..... B-14 | 00531007..... C-33 | 00760196..... N-23 | 00840117..... D-17 |
| 00110104..... C-6 | 00310002..... C-4 | 00510801..... B-14 | 00531101..... C-31 | 00760198..... N-23 | 00840118..... D-17 |
| 00110105..... C-6 | 00310003..... C-4 | 00510821..... B-14 | 00531102..... C-31 | 00760199..... N-23 | 00840301..... D-8 |
| 00110106..... C-6 | 00310004..... C-4 | 00510822..... B-14 | 00539090..... B-5 | 00760200..... N-23 | 00840302..... D-8 |
| 00110107..... C-6 | 00310005..... C-4 | 00510841..... B-14 | 00539091..... B-5 | 00760201..... N-23 | 00841100..... D-8 |
| 00110108..... C-6 | 00310006..... C-4 | 00510861..... B-14 | 00539092..... B-5 | 00760202..... N-23 | 00841101..... D-8 |
| 00110109..... C-6 | 00310007..... C-4 | 00510871..... B-14 | 00539093..... B-5 | 00760207..... N-23 | 00841102..... D-8 |
| 00110110..... C-6 | 00310008..... C-4 | 00510911..... B-22 | 00560013..... B-8 | 00760220..... N-19 | 00841800..... D-8 |
| 00110111..... C-6 | 00310009..... C-4 | 00510915..... B-23 | 29, 30, 31, 32, 33 | 00760221..... N-19 | 00841801..... D-8 |
| 00110112..... C-6 | 00310010..... C-4 | 00510921..... B-22 | 00560031..... C-29, 30, 31 | 00760222..... N-30 | 00841802..... D-8 |
| 00110113..... C-6 | 00311301..... C-10 | 00510922..... B-22 | 00560090..... C-32, 33 | 00760223..... N-29 | 00842600..... D-8 |
| 00111901..... C-23 | 00312301..... C-27 | 00510941..... B-22 | 00560095..... B-21 | 00760232..... N-24 | 00842601..... D-8 |
| 00111902..... C-23 | | 00510942..... B-22 | 00560096..... B-21 | | 00842602..... D-8 |
| 00111903..... C-23 | 004 | 00512015..... B-23 | 00560097..... B-21 | 008 | 00843101..... D-17 |
| 00111904..... C-23 | 00440001..... C-17 | 00512016..... B-23 | 00560098..... B-21 | 00810001..... D-3 | 00843200..... D-17 |
| 00111905..... C-23 | 00440002..... C-17 | 00512017..... B-23 | 00560099..... B-21 | 00810002..... D-3 | 00843201..... D-17 |
| 00119046..... C-7 | 00440003..... C-17 | 0051610365..... B-8 | 00560100..... B-21 | 00810003..... D-3 | 00843230..... D-17 |
| 00119047..... C-7 | 00440004..... C-17 | 00520001..... B-7 | 00560101..... B-21 | 00810801..... D-3 | 00843239..... D-17 |
| 00119048..... C-7 | 00440005..... C-17 | 00520002..... B-6 | 00560102..... B-21 | 00810802..... D-3 | 00860001..... D-8 |
| 00119049..... C-7 | 00440006..... C-17 | 00530020..... C-30 | 00560103..... B-18 | 00810803..... D-3 | 00860007..... D-8 |
| 00119050..... C-7 | 00440007..... C-17 | 00530021..... C-30 | 00560104..... B-18 | 00811501..... D-3 | 00860008..... D-8 |
| 00140101..... C-23 | | 00530094..... B-4 | 00560105..... B-18 | 00811502..... D-3 | 00860011..... D-8 |
| 00140301..... C-22 | 005 | C-31, 33 | 00590061..... B-20 | 00811503..... D-3 | 00860012..... D-8 |
| 00160101..... E-7 | 00510004..... B-7 | 00530095..... B-4 | 00590062..... B-20 | 00811504..... D-3 | 00860015..... D-8 |
| 00160201..... C-25 | 00510008..... B-6, 30 | 00530096..... B-4 | 00590063..... B-20 | 00812301..... D-3 | 00860016..... D-8 |
| | 00510033..... C-29 | 00530097..... B-4 | 00590064..... B-20 | 00812302..... D-3 | 00860017..... D-8 |
| 002 | 00510041..... B-9, C-29 | 00530103..... B-9 | 00590065..... B-20 | 00812303..... D-3 | 00862601..... D-8 |
| 00210001..... C-18 | 00510045..... B-6 | 00530104..... B-9 | 00590066..... B-20 | 00812304..... D-3 | 00863005..... D-8 |
| 00210002..... C-18 | 00510046..... B-6 | 00530105..... B-9 | 00590067..... B-20 | 00812305..... D-3 | 00863016..... D-8 |
| 00210003..... C-18 | 00510047..... B-9 | 00530110..... B-9 | | 00812306..... D-3 | 00863017..... D-8 |
| 00210004..... C-18 | 00510050..... B-6 | 00530111..... B-9 | 006 | 00812601..... D-3 | 00863035..... D-8 |
| 00210101..... C-11 | 00510111..... B-17 | 00530112..... B-9 | 00630001..... J-15 | 00812602..... D-3 | |
| 00210102..... C-11 | 00510123..... B-17 | 00530120..... B-9 | 00630002..... J-15 | 00812603..... D-3 | |
| 00210201..... C-15 | 00510124..... B-17 | 00530121..... B-9 | 00630010..... J-14 | 00812604..... D-3 | |
| 00210202..... C-15 | 00510125..... B-17 | 00530130..... B-9 | | 00813101..... D-3 | |
| 00210203..... C-15 | 00510126..... B-17 | 00530131..... B-9 | 007 | 00813102..... D-3 | |
| 00210204..... C-15 | 00510133..... B-17 | 00530319..... B-3, C-32 | 0071684815..... N-29 | 00813103..... D-3 | |
| 00210205..... C-15 | 00510134..... B-17 | 00530320..... B-3, C-32 | 0071684816..... N-29 | 00813104..... D-3 | |
| 00210206..... C-15 | 00510143..... B-17 | 00530321..... B-3, C-33 | 0071684817..... N-29 | 00813410..... D-3 | |
| 00210301..... C-14 | 00510144..... B-17 | 00530322..... B-3 | 0071684818..... N-29 | 00813411..... D-3 | |
| 00211002..... C-26 | 00510163..... B-17 | 00530323..... B-3 | 0071684819..... N-29 | 00813412..... D-3 | |
| 00211003..... C-26 | 00510164..... B-17 | 00530421..... B-10 | 0071684820..... N-29 | 00813413..... D-3 | |
| 00211004..... C-26 | 00510173..... B-17 | 00530422..... B-10 | 0071684822..... N-29 | 0081625081..... D-10 | |
| 00211005..... C-26 | 00510175..... B-18 | 00530423..... B-10 | 0071684825..... N-29 | 0081625082..... D-10 | |
| 00211201..... C-28 | 00510177..... B-18 | 00530424..... B-10 | 0071684826..... N-29 | 0081625083..... D-10 | |
| 00219066..... C-21 | 00510179..... B-18 | 00530425..... B-10 | 0071684827..... N-29 | 0081625084..... D-10 | |
| 00240015..... C-19 | 00510181..... B-18 | 00530426..... B-10 | 0071684828..... N-29 | 0081725001..... D-9 | |
| 00240501..... C-19 | 00510201..... B-18 | 00530427..... B-10 | 0071684829..... N-29 | 0081725003..... D-9 | |
| 00240502..... C-19 | 00510202..... B-18 | 00530430..... B-12 | 0071684832..... N-29 | 0081725006..... D-9 | |
| 00240503..... C-19 | 00510211..... B-18 | 00530431..... B-11 | 00730033..... N-13 | 0081725008..... D-9 | |
| 00240504..... C-19 | 00510212..... B-18 | 00530432..... B-11 | 00730034..... N-13 | 0081725010..... D-9 | |
| 00240505..... C-19 | 00510222..... B-18 | 00530433..... B-11 | 00730035..... N-13 | 0081725012..... D-9 | |
| 00240601..... C-19 | 00510371..... B-23 | 00530434..... B-11 | 00730043..... N-8 | 0081725014..... D-9 | |
| 00240602..... C-19 | 00510375..... B-23 | 00530435..... B-11 | 00730044..... N-8 | 0081725016..... D-9 | |
| 00240603..... C-19 | 00510383..... B-23 | 00530436..... B-11 | 00730045..... N-11 | 0081725018..... D-9 | |
| 00240700..... C-20 | 00510385..... B-23 | 00530437..... B-11 | 00730046..... N-11 | 0081725020..... D-9 | |
| 00240701..... C-20 | 00510387..... B-23 | 00530441..... B-15 | 00730047..... N-5 | 0081725022..... D-9 | |
| 00240702..... C-20 | 00510393..... B-23 | 00530442..... B-15 | 00730049..... N-22 | 0081725024..... D-9 | |
| 00240703..... C-20 | 00510506..... B-13 | 00530443..... B-15 | 00730057..... N-11 | 0081725026..... D-9 | |
| 00240704..... C-20 | 00510509..... B-13 | 00530444..... B-15 | 00730058..... N-11 | 0081725028..... D-9 | |
| 00240705..... C-20 | 00510511..... B-13 | 00530445..... B-15 | 00730059..... N-5 | 0081725030..... D-9 | |
| 00240706..... C-20 | 00510512..... B-13 | 00530446..... B-15 | 00730063..... N-17 | 0081725032..... D-9 | |
| 00240707..... C-20 | 00510521..... B-13 | 00530447..... B-15 | 00730064..... N-17 | 0081725034..... D-9 | |
| 00240708..... C-20 | 00510522..... B-13 | 00530448..... B-16 | 00730065..... N-17 | 0081725036..... D-9 | |
| 00240709..... C-20 | 00510531..... B-13 | 00530449..... B-16 | 00760058..... O-67 | 0081725038..... D-9 | |
| 00240710..... C-20 | 00510541..... B-13 | 00530450..... B-16 | 00760059..... O-67 | 00840001..... D-8 | |
| 00240711..... C-20 | 00510542..... B-13 | 00530451..... B-16 | 00760060..... O-67 | 00840101..... D-17 | |
| 00240712..... C-20 | 00510551..... B-13 | 00530471..... B-19 | 00760066..... O-67 | 00840102..... D-17 | |
| 00240713..... C-20 | 00510601..... B-13 | 00530473..... B-19 | 00760067..... O-67 | 00840103..... D-17 | |
| 00240714..... C-20 | 00510611..... B-13 | 00530474..... B-19 | 00760068..... O-67 | 00840104..... D-17 | |
| 00240715..... C-20 | 00510621..... B-13 | 00530475..... B-19 | 00760074..... O-67 | 00840105..... D-17 | |
| 00240716..... C-20 | 00510641..... B-13 | 00530509..... B-13 | 00760075..... O-67 | 00840106..... D-17 | |
| 00250015..... C-19 | 00510651..... B-13 | 00530521..... B-13 | 00760076..... O-67 | 00840107..... D-17 | |
| 00250115..... C-19 | 00510661..... B-13 | 00530531..... B-13 | 00760082..... O-67 | 00840108..... D-17 | |
| 00250501..... C-19 | 00510671..... B-13 | 00530701..... B-14 | 00760096..... O-67 | 00840109..... D-17 | |
| 00250502..... C-19 | 00510681..... B-13 | 00530721..... B-14 | 00760140..... N-20 | 00840110..... D-17 | |
| 00250503..... C-19 | 00510691..... B-13 | 00530741..... B-14 | 00760148..... N-26 | 00840111..... D-17 | |
| 00250504..... C-19 | 00510701..... B-14 | 00530821..... B-14 | 00760163..... N-15 | 00840112..... D-17 | |





| | | | | | | | | | | | |
|----------|----------|------------|----------|------------|----------|------------|----------|------------|----------|------------|----------|
| 03939219 | Q-9 | 03969282 | Q-11 | 04981004 | A-4 | 05969011 | L-13 | 06130110 | D-5 | 06830401 | P-15 |
| 03939240 | Q-4 | 03969283 | Q-11 | | Q-20 | 05969012 | L-13 | 06130111 | D-5 | 06830428 | P-15 |
| 03939241 | Q-4 | 03969284 | Q-11 | | | 05969020 | L-12 | 06130112 | D-5 | 06830601 | P-16 |
| 03939242 | Q-4 | 03969286 | Q-11 | 050 | | 05969021 | L-12 | 06130113 | D-5 | 06830602 | P-16 |
| 03939243 | Q-4 | 03969292 | Q-14 | 05030010 | O-55 | 05969022 | L-12 | 06130114 | D-5 | 06860001 | P-22, 25 |
| 03939267 | Q-5 | 03969293 | Q-11 | 05030012 | A-8 | 05969023 | L-12 | 06130115 | D-5 | 06860002 | P-22, 25 |
| 03939268 | Q-5 | 03969294 | Q-11 | | O-56 | 05969024 | L-12 | 06130116 | D-5 | 06860003 | P-22, 25 |
| 03939269 | Q-5 | 03969295 | Q-11 | 050697 | Q-17, 18 | 05969032 | L-12 | 06130117 | D-5 | 06860004 | P-22, 25 |
| 03939350 | Q-10 | 03969301 | Q-12 | | | 05969033 | L-12 | 06130118 | D-5 | 06860005 | P-22, 25 |
| 03960172 | Q-21 | 03969302 | Q-12, 18 | 053 | | 05969034 | L-12 | 06130119 | D-5 | 06860006 | P-22, 25 |
| 03960175 | Q-21 | 03969303 | Q-12, 18 | 05330003 | J-5 | 05969007 | L-12 | 06130120 | D-5 | 06860015 | P-22 |
| 03960270 | Q-21 | 03969304 | Q-12, 18 | 05330004 | J-5 | 05969008 | L-12 | 06130121 | D-5 | 06860016 | P-22 |
| 03969001 | Q-21 | 03969305 | Q-12 | 05330005 | J-5 | | | 06130122 | D-5 | 06860017 | P-22 |
| 03969003 | Q-21 | 03969310 | Q-12 | 05330202 | J-4 | | | 06130123 | D-5 | 06860018 | P-25 |
| 03969007 | A-10 | 03969312 | Q-12 | 05330203 | J-3 | 060 | | 06130124 | D-5 | 06860020 | P-22, 25 |
| 03969009 | Q-20 | 03969320 | Q-15 | 05331000 | J-9 | 06030010 | C-3 | 06130125 | D-5 | 06860021 | P-22, 25 |
| 03969010 | Q-19 | 03969324 | Q-12 | 05331002 | J-9 | | C-32, 33 | 06130126 | D-5 | 06860022 | P-22 |
| 03969011 | Q-21 | 03969326 | Q-12 | 05331050 | J-8 | 06030020 | C-3, 32 | 06130127 | D-5 | 06860022 | P-22 |
| 03969044 | Q-15, 18 | 03969330 | Q-13 | 05331054 | J-8 | 06030021 | C-3 | 06130128 | D-5 | 06860024 | P-22, 25 |
| 03969045 | Q-15, 18 | 03969332 | Q-12 | 05331058 | J-8 | 06030022 | C-3 | 06160002 | D-8 | 06860025 | P-22, 25 |
| 03969046 | Q-16, 18 | 03969343 | Q-12 | 05331061 | J-8 | 06030023 | C-3 | 06160003 | D-8 | 06860026 | P-25 |
| 03969047 | Q-18, 21 | 03969353 | Q-12 | 05331063 | J-8 | 06030029 | C-3 | 06160005 | D-8 | 06860027 | P-22 |
| 03969054 | Q-16, 18 | 03969504 | Q-19 | 05331063 | J-8 | 06030030 | C-3, 33 | 06160007 | D-8 | 06860029 | P-22 |
| 03969055 | Q-14 | 03969505 | Q-19 | 05331201 | J-8 | 06030031 | C-3 | 06160006 | D-8 | 06860030 | P-17 |
| 03969056 | Q-14 | 03969506 | Q-19 | 05331202 | J-8 | 06030032 | C-3 | 06160007 | D-8 | 06860031 | P-17 |
| 03969057 | Q-14 | 03969507 | Q-19 | 05331204 | J-8 | 06030033 | C-3 | 06230023 | D-11 | 06860032 | P-17 |
| 03969058 | Q-14 | 03969508 | Q-19 | 05331206 | J-8 | 06030034 | C-10 | 06230024 | D-11 | 06860033 | P-17 |
| 03969061 | Q-16 | 03969509 | Q-19 | 05331210 | J-8 | 06030035 | C-10 | 06230025 | D-11 | 06860046 | P-19 |
| 03969062 | Q-17 | 03969510 | Q-19 | 05331450 | J-9 | 06030038 | C-27 | 06230026 | D-11 | 06860056 | P-25 |
| 03969065 | Q-21 | 03969511 | Q-21 | 05331500 | J-7 | 06030039 | C-27 | 06230027 | D-11 | 06860057 | P-25 |
| 03969081 | Q-14 | | | 05331502 | J-7 | 06030040 | C-27 | 06230028 | D-11 | 06860058 | P-25 |
| 03969082 | Q-14, 18 | 042 | | 05331550 | J-7 | 06030041 | C-15 | 06230029 | D-11 | 06860059 | P-25 |
| 03969083 | Q-14 | 042086 | Q-17 | 05331551 | J-7 | 06030042 | C-15 | 06230030 | D-11 | 06860060 | P-22 |
| 03969084 | Q-14 | | | 05331750 | J-10 | 06030043 | C-15 | 06230031 | D-11 | 06860061 | P-22 |
| 03969085 | Q-18 | 044 | | 05360004 | J-11 | 06030044 | C-15 | 06230032 | D-11 | 06860145 | P-18 |
| 03969095 | Q-21 | 04430003 | O-53 | 05360006 | J-11 | 06030045 | C-16 | 06230033 | D-11 | 06860186 | P-18 |
| 03969103 | Q-21 | 04430008 | O-47 | 05360014 | J-11 | 06030047 | C-22 | 06230034 | D-11 | 06860187 | P-19 |
| 03969201 | Q-11, 18 | 04430009 | O-49 | 056 | | 06030048 | C-22 | 06230035 | D-11 | 06860287 | P-17 |
| 03969202 | Q-11, 18 | 04430010 | O-49 | 056109 | A-12 | 06030049 | C-22 | 06230036 | D-11 | 06860288 | P-17 |
| 03969203 | Q-11, 18 | 04430011 | O-51 | 056133 | M-21 | 06030050 | C-22 | 06230037 | D-11 | 06860289 | P-17 |
| 03969204 | Q-11, 18 | 04430012 | L-7 | 056223 | M-21 | 06030051 | C-22 | 06230038 | D-11 | 06860290 | P-17 |
| 03969205 | Q-11 | | | 056224 | M-22 | 06030062 | C-18 | 06230039 | D-11 | 06860400 | P-18 |
| 03969206 | Q-11 | 04460004 | O-54 | 056631 | M-22 | 06030063 | C-18 | 06230051 | D-11 | 06860401 | P-18 |
| 03969208 | Q-11 | 04460007 | O-54 | 056633 | M-22 | 06030064 | C-18 | 06230052 | D-11 | 06869055 | P-22 |
| 03969210 | Q-14 | | | 056639 | M-22 | 06030065 | C-18 | | | 06869056 | P-22 |
| 03969212 | Q-11, 18 | 047 | | 056641 | M-22 | 06030066 | C-18 | 064 | | 06869057 | P-22 |
| 03969213 | Q-11, 18 | 04760087 | L-7 | | | 06030067 | C-18 | 06430000 | A-6 | 06869101 | P-28 |
| 03969214 | Q-11, 18 | 04760099 | A-12 | 057 | | 06030069 | C-26 | | | 06869102 | P-28 |
| 03969218 | Q-13 | 04760180 | A-7 | 05710012 | H-6 | 06030070 | C-26 | 065 | | 06869106 | P-28 |
| 03969220 | Q-11 | 04760181 | A-10 | 05710013 | H-6 | 06030071 | C-3 | 065151011 | K-6 | 06869107 | P-28 |
| 03969221 | Q-11, 18 | 04760182 | A-10 | 05710014 | H-6 | 06030072 | C-3 | 065151012 | K-6 | 06869108 | P-28 |
| 03969222 | Q-11 | 04761017 | A-11 | 05710015 | H-6 | 06030073 | C-3 | 065151014 | K-5 | 06869109 | P-28 |
| 03969223 | Q-11 | 04761023 | A-10 | 05710016 | H-6 | 06030074 | C-3 | 065151021 | K-5 | 06869110 | P-28 |
| 03969224 | Q-11 | 04761024 | A-10 | 05710017 | H-6 | 06030075 | C-3 | 065151027 | K-5 | 06869111 | P-28 |
| 03969225 | Q-11 | 04761027 | A-9 | 05710018 | H-6 | 06030076 | C-3 | 0651512011 | K-6 | 06869112 | P-28 |
| 03969226 | Q-11 | 04761037 | A-11 | 05710018 | H-6 | 06030077 | C-3 | 0651512012 | K-6 | 06869113 | P-28 |
| 03969230 | Q-15 | 04761038 | A-10 | 05710090 | H-5 | 06030078 | C-3 | 0651512014 | K-5 | 06869118 | P-28 |
| 03969231 | Q-15, 18 | 04761046 | A-9 | 05710091 | H-5 | 06030079 | C-12 | 0651512021 | K-5 | 06869119 | P-28 |
| 03969232 | Q-15, 18 | 04761049 | A-9 | 05710092 | H-5 | 06030080 | C-12 | 0651512028 | K-5 | 06869120 | P-28 |
| 03969233 | Q-15, 18 | | | 05710093 | H-5 | 06030081 | C-12 | 0651515011 | K-6 | 06869121 | P-28 |
| 03969234 | Q-15 | 04761052 | A-9 | 05740001 | H-7 | 06030082 | C-12 | 0651515012 | K-6 | 06869122 | P-28 |
| 03969238 | Q-15 | 04761054 | A-11 | 05760013 | H-7 | 06030083 | C-12 | 0651515014 | K-5 | | |
| 03969239 | Q-15 | 04761054 | A-11 | 05760027 | H-7 | 06030084 | C-12 | 0651515021 | K-5 | 069 | |
| 03969240 | Q-15 | 04761055 | A-11 | 05760029 | H-7 | 06030085 | C-14 | 0651515027 | K-5 | 06930011 | M-8 |
| 03969246 | Q-15 | | | 057655 | M-22 | 06030087 | C-17 | 0651516011 | K-6 | 06930012 | M-11 |
| 03969247 | Q-15 | | | | | 06030088 | C-17 | 0651516012 | K-6 | 06930013 | M-5 |
| 03969251 | Q-14 | 04761056 | A-11 | 058 | | 06030089 | C-17 | 0651516014 | K-5 | 06960033 | M-20 |
| 03969252 | Q-14 | | | 058213 | A-12 | 06030090 | C-17 | 0651516021 | K-5 | 06960034 | M-14 |
| 03969253 | Q-14 | 04761057 | A-11 | | | 06030091 | C-17 | 0651516027 | K-5 | 06960035 | M-23 |
| 03969259 | Q-11 | 04761059 | J-11 | 059 | | 06030092 | C-17 | 0652500422 | K-7 | 06960036 | M-17 |
| 03969260 | Q-11, 18 | 04761060 | A-10 | 05930000 | L-7 | 06030093 | C-17 | | | 06960037 | M-18 |
| 03969261 | Q-11 | 04761062 | A-9 | 05930003 | L-7 | 06030094 | C-17 | 067 | | 06960038 | M-18 |
| 03969262 | Q-11 | 04761063 | A-9 | 05930004 | L-5 | 06030095 | C-17 | 06719000 | J-16 | 06960039 | M-18 |
| 03969263 | Q-11 | 04761070 | L-7 | 05930008 | L-5 | 06030096 | C-17 | 06739001 | J-13 | 06960040 | M-18 |
| 03969267 | Q-11 | 04761071 | A-5 | 05930011 | L-9 | 06030097 | C-17 | 06769002 | K-8 | 06960041 | M-24 |
| 03969268 | Q-11 | 04768000 | A-11 | 05930013 | L-7 | 06060021 | C-26 | 06769004 | I-24 | 06960042 | M-22 |
| 03969269 | Q-11 | | | 05930015 | L-7 | | | 06769005 | J-16 | 06960043 | M-21 |
| 03969270 | Q-15, 18 | 04768001 | A-11 | 05939001 | L-11 | 061 | | 06769006 | I-23 | 06960044 | M-21 |
| 03969271 | Q-11 | 04768002 | J-11 | 05960025 | L-8 | 06130101 | D-5 | 06769007 | I-24 | 06960045 | M-22 |
| 03969272 | Q-11 | | | 05960030 | L-7 | 06130102 | D-5 | | P-22, 25 | 06960046 | M-22 |
| 03969276 | Q-11 | 047866 | Q-17, 18 | 05960039 | L-7 | 06130103 | D-5 | 06769009 | K-8 | 06960048 | M-15 |
| 03969277 | Q-15 | | | 05969000 | L-12 | 06130104 | D-5 | 06769010 | I-25 | 06960049 | M-17 |
| 03969278 | Q-15 | 049 | | 05969001 | L-12 | 06130105 | D-5 | | | 06960050 | M-19 |
| 03969279 | Q-15 | 049652 | Q-18 | 05969002 | L-13 | 06130106 | D-5 | 068 | | 06960051 | M-19 |
| 03969280 | Q-15 | 04981001 | A-3 | 05969004 | L-13 | 06130107 | D-5 | 06830031 | P-26 | 06960052 | M-19 |
| 03969281 | Q-15 | | | 05969009 | L-13 | 06130108 | D-5 | 06830034 | P-26 | 06960053 | M-19 |
| | | 04981002 | A-4 | 05969010 | L-13 | 06130109 | D-5 | 06830035 | P-26 | 06960054 | M-19 |





| | | | | | | | | | | | |
|------------|----------|------------|------|------------|------|----------|----------|--------------|----------|-----------|--------|
| 06960055 | M-23 | 075115821 | B-7 | 0951753002 | I-26 | CJ1B4A | K-14 | CJ1L1S0 | K-9 | S47010025 | A-9 |
| 06960056 | M-18, 19 | 076 | | 0951753003 | I-26 | CJ1B4C | K-14 | CJ1L1S2 | K-9 | S47078588 | A-10 |
| 06960057 | M-18 | 076115566 | J-15 | 0951753013 | I-26 | CJ1B4IA | K-14 | CJ1L2E0 | K-9 | S47120002 | A-5, 9 |
| 06960058 | M-19 | 076115567 | J-15 | 0951753014 | I-26 | CJ1B4IM | K-14 | CJ1L2E2 | K-9 | S47120003 | A-5 |
| 06960059 | M-22 | 077 | | 0951753015 | I-26 | CJ1B5A | K-14 | CJ1L2S0 | K-9 | S48001721 | O-57 |
| 06960061 | M-19 | 07739001 | N-31 | 0951753045 | I-26 | CJ1B5C | K-14 | CJ1L2S2 | K-9 | S48001722 | O-57 |
| 06960062 | A-12 | 07739002 | N-31 | 0951753046 | I-26 | CJ1B5IA | K-14 | CJ1L5E0 | K-10 | S48001723 | O-57 |
| 06960064 | M-24 | 07739003 | N-31 | 0951754511 | I-27 | CJ1B5IM | K-14 | CJ1L5E2 | K-10 | S48001724 | O-57 |
| 06960065 | M-24 | 07769001 | N-31 | 82 | | CJ1BAA | K-16 | CJ1L5S0 | K-10 | S48001725 | O-57 |
| 06960066 | M-24 | 07769003 | N-31 | 82-1631 | Q-21 | CJ1BBA | K-16 | CJ1L5S2 | K-10 | S48001731 | O-57 |
| 06960067 | M-19 | 07769004 | N-31 | 200 | | CJ1BBA1 | K-15 | CJ1L10E0 | K-10 | S53070174 | A-10 |
| 06960081 | M-18 | 07769003 | N-31 | 212GL | G-11 | CJ1BBA2 | K-15 | CJ1L10E2 | K-10 | S53300165 | A-10 |
| 06960100 | M-13 | 07769005 | N-31 | 212L | G-11 | CJ1BBA3 | K-15 | CJ1L10S0 | K-10 | S59110152 | L-8 |
| 06960101 | M-16 | 07769006 | N-31 | 213G | G-11 | CJ1BBA4 | K-15 | CJ1L10S2 | K-10 | S59110489 | L-8 |
| 06960102 | M-17 | 078 | | 215 | G-11 | CJ1BBA5 | K-15 | CJ1LL1E0 | K-10 | S59300103 | L-9 |
| 06960103 | M-24 | 078110733 | D-13 | 215G | G-11 | CJ1BBA6 | K-15 | CJ1LL1S0 | K-10 | S59300104 | L-9 |
| 071 | | 078110735 | D-13 | 215GL | G-11 | CJ1BBA7 | K-15 | CJ1LL2E0 | K-10 | S59300107 | L-9 |
| 071115887 | C-5 | 078110737 | D-13 | 216G | G-11 | CJ1BBA8 | K-15 | CJ1LL2S0 | K-10 | T | |
| 071115888 | C-5 | 078110739 | D-13 | 216G | G-11 | CJ1BBA9 | K-15 | CJ1MXXK | K-13, 16 | TL01-0002 | P-9 |
| 071115889 | C-5 | 078112356 | D-13 | 222GL | G-11 | CJ1BBM1 | K-15 | CJ1N1E | K-13 | TL01-0003 | P-9 |
| 071115890 | C-5 | 078112357 | D-13 | 222L | G-11 | CJ1BBM2 | K-15 | CJ1N1S | K-13 | TL01-0004 | P-9 |
| 071115891 | C-5 | 078112358 | D-13 | 223 | G-11 | CJ1BBM3 | K-15 | CJ1N2E | K-13 | TL01-0005 | P-9 |
| 071115892 | C-5 | 078112359 | D-13 | 223G | G-11 | CJ1BBM4 | K-15 | CJ1N2S | K-13 | TL01-0006 | P-9 |
| 071115893 | C-5 | 078112360 | D-13 | 225 | G-11 | CJ1BBM5 | K-15 | CJ1N3 | K-13, 16 | TL01-0007 | P-9 |
| 071115894 | C-5 | 078112361 | D-13 | 225G | G-11 | CJ1BBM6 | K-15 | CJ1N3E | K-13 | TL01-0008 | P-9 |
| 071115940 | C-13 | 078112362 | D-13 | 232GL | G-12 | CJ1BBM7 | K-15 | CJ1N3S | K-13 | TL01-0009 | P-9 |
| 072 | | 078112363 | D-13 | 232L | G-12 | CJ1BBM8 | K-15 | CJ1N4E | K-13 | TL01-0010 | P-9 |
| 072103522 | C-13 | 078112364 | D-13 | 233 | G-12 | CJ1BBM9 | K-15 | CJ1N4S | K-13 | TL01-0011 | P-9 |
| 072108669 | C-8 | 078112365 | D-13 | 233G | G-12 | CJ1BOA1 | K-15 | CJ1N50 | K-13, 16 | TL01-0012 | P-9 |
| 072108691 | C-8 | 078112366 | D-13 | 235G | G-12 | CJ1BOA2 | K-15 | CJ1NGC | K-13, 16 | TL01-0013 | P-9 |
| 072108722 | C-8 | 078112367 | D-13 | 242 | G-12 | CJ1BOA3 | K-15 | CJ1NLSM | K-13, 16 | TL01-0015 | P-10 |
| 072110123 | C-25 | 078112368 | D-13 | 242G | G-12 | CJ1BOA4 | K-15 | CJ1PTXK | K-13, 16 | TL01-0016 | P-10 |
| 072110816 | C-9 | 078112369 | D-13 | 243GL | G-12 | CJ1BOA5 | K-15 | CJ1X1E0 | K-11 | TL01-0017 | P-10 |
| 072110853 | C-9 | 078112370 | D-13 | 243L | G-12 | CJ1BOA6 | K-15 | CJ1X1E2 | K-11 | TL01-0018 | P-10 |
| 072110978 | C-8 | 078112371 | D-13 | 245 | G-12 | CJ1BOA7 | K-15 | CJ1X1S0 | K-11 | TL01-0019 | P-10 |
| 072112020 | C-24 | 078112372 | D-13 | 245G | G-12 | CJ1BOA8 | K-15 | CJ1X1S2 | K-11 | TL01-0020 | P-10 |
| 072112021 | C-24 | 078112373 | D-13 | 353 | F-11 | CJ1BOA9 | K-15 | CJ1X1S10 | K-11 | TL01-0021 | P-10 |
| 072115943 | C-28 | 079 | | 353E | F-11 | CJ1BOM1 | K-15 | CJ1X2E0 | K-11 | TL01-0022 | P-10 |
| 072116406 | C-5 | 079105694 | H-8 | 355 | F-15 | CJ1BOM2 | K-15 | CJ1X2E2 | K-11 | TL01-0026 | P-10 |
| 072116407 | C-5 | 079105704 | H-8 | 355E | F-15 | CJ1BOM3 | K-15 | CJ1X2E10 | K-11 | TL01-0027 | P-10 |
| 072116408 | C-5 | 079105756 | H-8 | 365S | F-15 | CJ1BOM4 | K-15 | CJ1X2S0 | K-11 | TL01-0038 | P-11 |
| 072116409 | C-5 | 079111401 | H-8 | 367 | F-17 | CJ1BOM5 | K-15 | CJ1X2S2 | K-11 | TL01-0039 | P-11 |
| 072116410 | C-11 | 079112051 | H-8 | 367E | F-17 | CJ1BOM6 | K-15 | CJ1X2S10 | K-11 | TL01-0040 | P-11 |
| 074 | | 079112052 | H-8 | 367E | F-17 | CJ1BOM7 | K-15 | CJ1X3E0 | K-11 | TL02-0001 | P-11 |
| 074105993 | G-9 | 081 | | 300 | | CJ1BOM8 | K-15 | CJ1X3E10 | K-11 | TL02-0002 | P-11 |
| 074105994 | G-9 | 081112053 | M-25 | 512K | F-12 | CJ1BOM9 | K-15 | CJ1X3S0 | K-11 | TL02-0003 | P-11 |
| 074105995 | G-9 | 081112054 | M-25 | 532 | F-12 | CJ1C1E0 | K-12 | CJ1X3S10 | K-11 | TL02-0016 | P-11 |
| 074106026 | G-8, 9 | 081112055 | M-25 | 532E | F-12 | CJ1C1S0 | K-12 | CJ1XDL | K-13, 16 | TL02-0017 | P-11 |
| 074106331 | G-8, 9 | 081112056 | M-25 | 533S | F-12 | CJ1C1S10 | K-12 | CJ1XX1E0 | K-11 | TL02-0018 | P-11 |
| 074106358 | G-9 | 081112057 | M-25 | 555 | F-16 | CJ1C2E0 | K-12 | CJ1XX1S0 | K-11 | TL02-0019 | P-11 |
| 074106360 | G-9 | 081112058 | M-25 | 555E | F-16 | CJ1C2E10 | K-12 | CJ1XX2E0 | K-11 | TL02-0021 | P-11 |
| 074107893 | G-9 | 081112059 | M-25 | 556 | F-18 | CJ1C2S0 | K-12 | CJ1XX2S0 | K-11 | TTA 20 | O-53 |
| 074107895 | G-9 | 081112060 | M-25 | 556E | F-18 | CJ1C3E0 | K-12 | CJ1XX3E0 | K-11 | Z | |
| 074107897 | G-9 | 081112061 | M-25 | 556G | F-19 | CJ1C3E10 | K-12 | CJ1XX4S0 | K-11 | Z173-0908 | P-11 |
| 074108603 | G-9 | 081112062 | M-25 | 567 | F-18 | CJ1C3S0 | K-12 | CJ1XX4S10 | K-11 | Z173-0920 | P-11 |
| 074108942 | G-8 | 081112063 | M-25 | 500 | | CJ1C3S10 | K-12 | CJ128021010A | K-16 | Z173-0921 | P-11 |
| 074110481 | G-9 | 081112064 | M-25 | 532E | F-12 | CJ1CB18 | K-16 | CJ128021011A | K-16 | Z173-0922 | P-11 |
| 074110482 | G-9 | 081112065 | M-25 | 533S | F-12 | CJ1CB24 | K-16 | CJ128021012A | K-16 | Z173-0923 | P-11 |
| 074110491 | G-9 | 081112066 | M-25 | 555 | F-16 | CJ1CB40 | K-16 | CJ128021013A | K-16 | Z173-0961 | P-12 |
| 074110492 | G-9 | 081112067 | M-25 | 555E | F-16 | CJ1CC1E0 | K-12 | CP 352S | F-24 | Z173-2020 | P-12 |
| 074110493 | G-9 | 081112068 | M-25 | 556 | F-18 | CJ1CC1S0 | K-12 | CP 353 | F-24 | Z173-2024 | P-12 |
| 074110507 | G-9 | 081112069 | M-25 | 556E | F-18 | CJ1CC2E0 | K-12 | CP 355 | F-24 | Z173-2025 | P-12 |
| 074111366 | G-8 | 081112070 | M-25 | 556G | F-19 | CJ1CC2S0 | K-12 | S | | Z178-0607 | P-12 |
| 074111367 | G-8 | 081112071 | M-25 | 567 | F-18 | CJ1CC3E0 | K-12 | S18001695 | G-4 | Z178-0610 | P-12 |
| 074111368 | G-8 | 081112072 | M-25 | 700 | | CJ1CC3S0 | K-12 | S39040070 | Q-20 | Z178-0940 | P-12 |
| 074111369 | G-8 | 081112073 | M-25 | 712 | F-13 | CJ1CEB3 | K-16 | S39040072 | Q-20 | Z178-0942 | P-12 |
| 074111375 | G-8 | 081112074 | M-25 | 722 | F-13 | CJ1CEB4 | K-16 | S39900072 | Q-21 | Z178-2009 | P-12 |
| 074111376 | G-8 | 081112075 | M-25 | 732 | F-13 | CJ1D1E0 | K-9 | S41077249 | O-59 | Z178-2020 | P-12 |
| 074111474 | G-8 | 081112076 | M-25 | 900 | | CJ1D1E2 | K-9 | S41078077 | O-59 | Z178-2025 | P-12 |
| 074111502 | G-8 | 081112077 | M-25 | 96160013 | O-40 | CJ1D1S0 | K-9 | S41078079 | O-59 | Z178-2026 | P-12 |
| 074111503 | G-8 | 081112078 | M-25 | 96410012 | O-39 | CJ1D1S2 | K-9 | S41078087 | O-59 | Z178-3028 | P-12 |
| 074111504 | G-8 | 081112079 | M-25 | 96430029 | O-41 | CJ1D2E0 | K-9 | S41078228 | O-59 | | |
| 074111505 | G-8 | 081112080 | M-25 | 96441041 | O-41 | CJ1D2E2 | K-9 | S41078230 | O-59 | | |
| 074115604 | H-9 | 081112081 | M-25 | C | | CJ1D2S0 | K-9 | S41078332 | O-59 | | |
| 074115605 | H-9 | 081112082 | M-25 | CJ1B1C | K-14 | CJ1D2S2 | K-9 | S41078354 | O-59 | | |
| 074115606 | H-9 | 081112083 | M-25 | CJ1B1IM | K-14 | CJ1EB12 | K-16 | S41078654 | O-59 | | |
| 074115607 | H-9 | 081112084 | M-25 | CJ1B2A | K-14 | CJ1ED25N | K-13, 16 | S41078751 | O-59 | | |
| 074115608 | H-9 | 081112085 | M-25 | CJ1B2C | K-14 | CJ1EL25N | K-13, 16 | S41078752 | O-59 | | |
| 074115664 | H-9 | 081112086 | M-25 | CJ1B2IA | K-14 | CJ1GTXX | K-13, 16 | S47001891 | A-11 | | |
| | | 081112087 | M-25 | CJ1B2IM | K-14 | CJ1L1E0 | K-9 | S47010022 | A-9 | | |
| | | 081112088 | M-25 | CJ1B3A | K-14 | CJ1L1E2 | K-9 | S47010024 | A-9 | | |
| | | 081112089 | M-25 | CJ1B3C | K-14 | | | | | | |
| | | 081112090 | M-25 | CJ1B3IA | K-14 | | | | | | |
| | | 081112091 | M-25 | CJ1B3IM | K-14 | | | | | | |

075

LEXICON OF PICTOGRAMS

| | | | |
|--|--|---|--|
|  TESA Design SWISS MADE |  Height of signs/digits |  Diameter |  Maximum relative humidity |
|  TESA Design – Product from the European Community |  Analogue/numerical indication |  Thread pitch |  Degree of protection |
|  TESA Design – Product produced outside Europe |  Material measure Measuring system |  Material hardness |  Electromagnetic compatibility |
|  Product from the European Community |  Capacitive measuring system "CAPA μ SYSTEM", patented |  Measuring force |  Mass |
|  Product produced outside Europe |  Magnetic measuring system "MAGNA μ SYSTEM", patented |  Shockproof design |  Included in scope of supply |
|  Order number |  Units of measurement |  Maximum displacement speed |  Packaging |
|  Standard |  Mm/in conversion |  Product designation |  Identification number |
|  Measuring range Measuring span |  Maximum permissible errors Limit deviations |  Execution |  Declaration of conformity |
|  Range of indication Max. plunger travel |  Deviation span of indication |  Special features |  Inspection report |
|  Displacement range |  Repeatability limit |  Notes |  Inspection report with a declaration of conformity |
|  Application range |  Hysteresis |  Function mode |  SCS calibration certificate |
|  Analogue indication Longitudinal scale |  Maximum permissible straightness error |  Floating zero |  Certificate of another type |
|  Upper vernier |  Maximum permissible flatness error |  Blocking of display |  Page |
|  Lower vernier |  Maximum permissible roundness error |  Locking of display |  Centred lug back |
|  Circular scale |  Maximum permissible parallelism error |  Digital interface |  Centred revolution counter |
|  Dial |  Maximum permissible cylindricity error |  Analogue interface |  Reverse numbering or +left |
|  mm or in/revolution |  Maximum permissible perpendicularity error |  Control functions |  Dial locking knob |
|  Number of scale divisions |  Maximum permissible runout error |  Power supply |  Connectivity |
|  Scale spacing |  Quality grade |  Autonomy |  TWIN |
|  Scale interval |  Uncertainty of measurement accuracy |  Coefficient of linear expansion |  ABS |
|  Resolution magnification |  Frame |  Working temperature range |  Height of signs/digits 11 mm |
|  Numerical scale |  Measuring face or faces |  Operating temperature range |  TESA |
|  Numerical interval |  Dimensions |  Storage temperature range |  HEXAGON |



2014
2015



BEYOND MEASUREMENT

The alliance between SWISS MADE and INNOVATION